

# KBN

## 1300C

High-rigidity Structure & Excellent Performance

HYUNDAI WIA Heavy Duty Boring Machine

# Technical Leader

The heavy duty boring machine KBΠ1300C, designed by Hyundai WIA with years of expertise and the latest technology, provides high performance and maximum productivity.

## KBΠ1300C

Pallet Size (L×W)	mm(in)	2,000×1,800 (78.7"×70.9")
Max. Load Capacity	kg(lb)	15,000 (33,069) [20,000 (44,092)]
Min. Indexing Angle	deg	0.001°
Spindle Quill Dia.	mm(in)	Ø130
Spindle Taper	-	NT #50
Spindle Speed	r/min	2,500
Spindle Power	kW (HP)	37/30 (50/40) [45/37] (60.3/50)
Spindle Driving Method	-	2 Step Gear Box (ZF reducer)
No. of Tools	EA	60 [90]
Travel (X/Y/Z/W)	mm(in)	3,000 [4,000]/2,000 [2500]/1500 [2000]/700 (118.1" [157.5" ]/78.7" [98.4" ]/59.1" [78.7" ]/27.6")
Rapid Traverse Rate	m/min(ipm)	10/10/10/8

[ ] : Option

# KBN 1300C

The Next Generation Boring Machine

- One-piece bed construction for ultra precision
- X-axis 4,000mm (157.5") as an option
- Gear Box driven spindle for heavy duty cutting
- Optimal boring machining with W-axis travel of 700mm (27.6")
- Standard linear scale and rotary scale for ultra precision



# 01 BASIC FEATURES

The Most Advanced Mechanism, Revolutionized Productivity & High Performance

## High Precision Spindle

- 2 Step Gear Spindle (2,500 r/min)
- W-axis 700 mm (27.6")

## ATC & Magazine

- Tool Shank : BT50 [DIN50, CAT50, BBT50]
- No. of Tools : 60 [Opt. 90] EA

## NC Rotary Table

- Table Size : 2,000 × 1,800 mm  
(78.74" × 70.86")
- Max. Load Capacity : 15,000 kg (33,069 lb)  
[20,000 kg (44,092 lb)]



Travel (X/Y/Z/W)

[ ] : Option

3,000 [4,000]/2,000 [2,500]/1,500 [2,000]/700 mm  
(118.1" [157.5"]/78.7" [98.4"]/59.1" [78.7"]/27.6")

Rapid Traverse Rate (X/Y/Z/W)

10/10/10/8 m/min  
(394/394/394/315 ipm)

# INCREASED RIGIDITY, OPTIMUM MACHINING CAPABILITY

## HIGH RIGIDITY STRUCTURE

### Stable Mechanical Structure

The X-bed, Z-bed, and column are designed with a high-rigidity casting structure to secure a high-rigidity and stable mechanical structure, and the guideway is ground precisely after heat treatment to ensure high stiffness and high precision.

## GUIDE WAY

### Hydraulic balance structure of the Y-axis

The hydraulic balance structure features an accumulator charged with high-pressure nitrogen gas, thereby guaranteeing smooth operation and high precision of the Y-axis.

In addition, noise has been eliminated and energy can be saved as the machine is not equipped with a hydraulic pump.

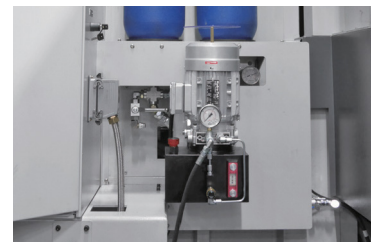

### Hand Scrapping

The counter surface was hand scrapped with Turcite attached, and a linear scale was installed as standard to ensure high precision, realizing the optimal conditions for improving processing quality.

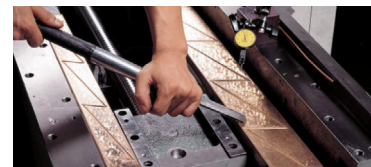

## HIGH PRECISION

### Std Linear & 1 sec Rotary Scales on All Axis

Linear scales on X/Y/Z-axis and rotary scale on B-axis provide High accuracy positioning and enabling precise machining.



# 02 HIGH PRECISION SPINDLE

Long Lasting, High Accuracy & Excellent Performance

## Std. Spindle

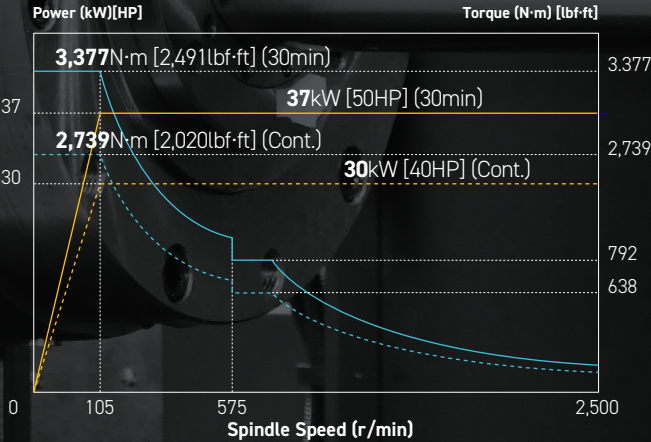

### Spindle Specifications

Spindle Speed

2,500 rpm

Power (Max./Cont.)

37/30 kW (50/40 HP)

Torque (Max./Cont.)

3,377/2,739 N·m (2,491/2,020 lbf·ft)

## Opt. High torque Spindle

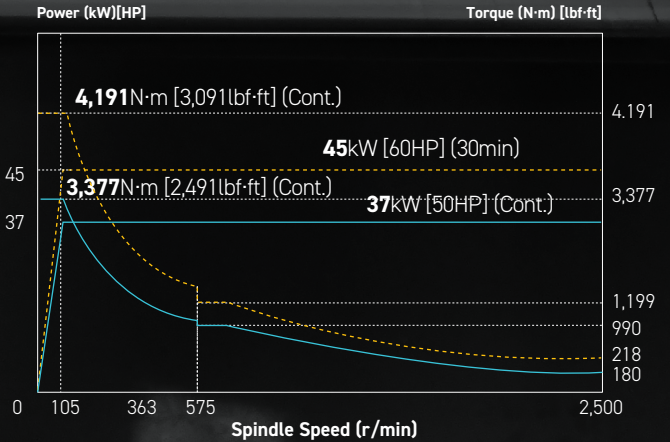

### Spindle Specifications

Spindle Speed

2,500 rpm

Power (Max./Cont.)

45/37 kW (60/50 HP)

Torque (Max./Cont.)

4,191/3,377 N·m (3,091/2,491 lbf·ft)

# HEAVY DUTY CUTTING, GEAR TYPE SPINDLE

## SPINDLE

### High-rigidity Spindle with Excellent Machining Capability

Cutting work can be carried out in conditions of perfect stability as access to the workpiece has been facilitated with the adoption of a nose-type head structure, and the protrusion distance of the boring spindle has been minimized. High-rigidity bearings have been applied to the milling spindle to support the spindle unit.

The milling spindle is designed and manufactured to withstand large loads during axial direction machining.

Also, the spindle is equipped with a large-capacity cooling device to maintain stable thermal displacement even during long-term operation, and that cools the gearbox (ZF reducer) and spindle cartridge.

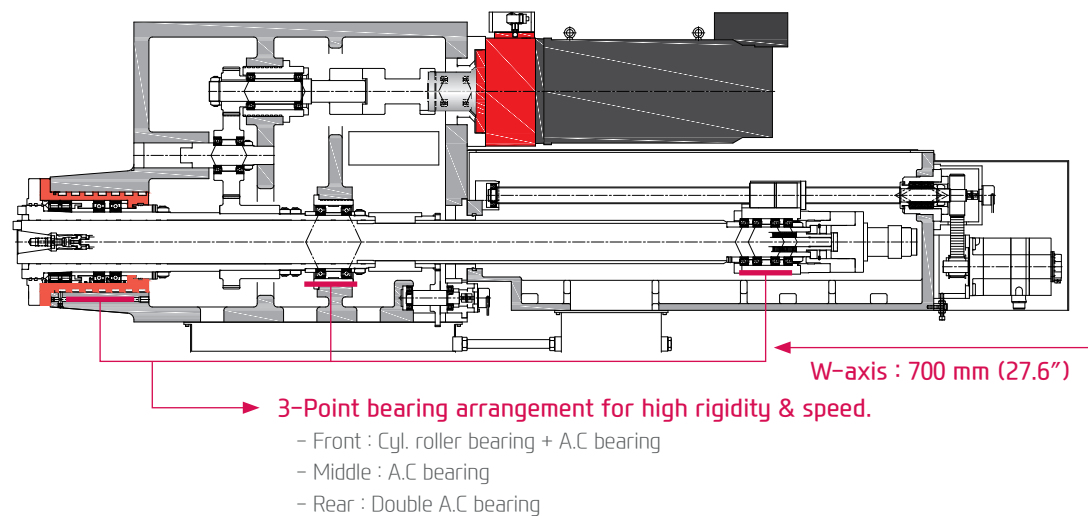

### Stable W-axis drive

The boring spindle is applied a W-axis ball screw and 2-way LM guide method. It is driven by a servo motor and a reduction pulley, and equipped with a high-precision encoder to guarantee the degree of feedback.



### HIGH CAPACITY SPINDLE COOLING DEVICE

Standard feature high capacity spindle cooling device(5,590kcal/h) enables stabilized spindle temperature during long operations. Stabilized spindle environment leads to high performance and high quality machining.

# 03 MAGAZINE & TABLE

High Productivity Achieved with High Rigidity, Accuracy Machining

## ATC & Magazine Specifications

[ ] : Option

No. of Tools	Max. Tool Dia. (W.T/W.O)	Max. Tool Length	Max. Tool Weight
60 [90] EA	Ø125/Ø250 mm (4.9"/9.8")	600 mm (23.6")	30 kg (66.1 lb)

## NC Rotary Table Specifications

Table Size (L×W)	Max. Load Capacity	Min. Indexing Angle	B-axis Driven
2,000×1,800 mm (78.7"×70.9")	15,000 kg (33,069 lb) [20,000 kg (44,092 lb)]	0.001°	Ring Gear



# HIGH RIGIDITY, TOOL CHANGE SYSTEM

## ATC & MAGAZINE

### Reliable Automatic Tool Changer (ATC)

The tool changer consists of a tool magazine and carriage driven by a servo motor to increase reliability.

The adoption of a hydraulic cylindrical structure allows it to function stably even when using heavy tools.

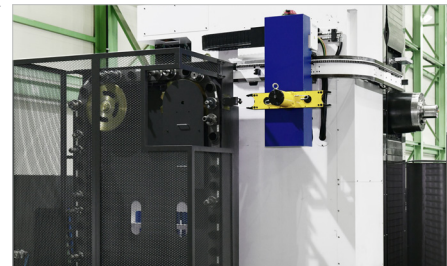

## TABLE

### NC Rotary Table

To ensure smooth operation of the rotary table under heavy loads, the center shaft is equipped with double roller bearings and thrust ball bearings.

Also, the rotary table features a thrust roller bearing structure and a strong bi-directional clamping structure that ensure stable processing conditions.

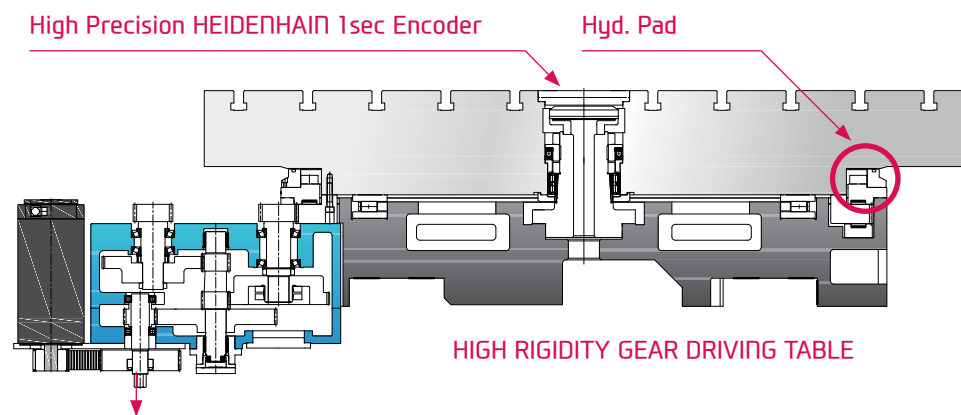
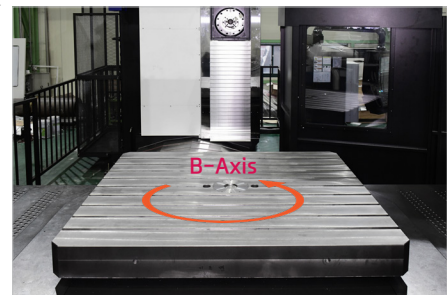

### B-Axis Double Pinion Gear

The drive of the table has a structure in which a gear box and double pinion rotate a large high-precision ring gear. High-precision encoder is installed at the center of the table as a standard feature, allowing precise control of the index.

# 04 USER CONVENIENCE



Various Devices for User Friendly

## CHIP DISPOSAL SOLUTION & COOLANT UNIT

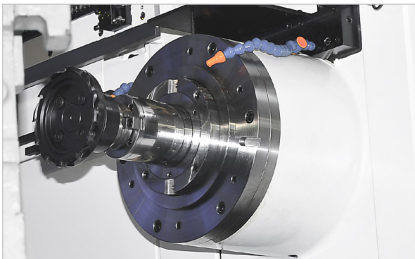

Spindle Nozzle & Cutting Air Blow



Gun Coolant



Air Gun



### Interior Screw Chip Conveyor

Dual screw type chip conveyors are located at each side of the bed which makes it convenient to remove chips.

### Chip Conveyor

Timely and effective disposal of chips will improve productivity as well as working environment.



### Through Spindle Coolant

Through spindle coolant is particularly useful for deep hole drilling and helps increase tool life and decrease cycle time.



Hinge	Chip Type : Roughing chip, long chip, chip complex	Material : SS41, 45C, Cast Steel	Left Direction
	Highly efficient when disposing a lot of chips. Capable of handling stringy chips..		
Scraper	Chip Type : Finely broken chip blown out	Material : cast Iron, Nonferrous	
	Convenient for shortly cut chips.		



#### Fire Safety

The use of a water-insoluble coolant or failure to use a coolant while machining inflammables may result in a fire. Unauthorized modification of the machine may also result in a risk of fire. Make sure to read and comply with the safety instructions before using the machine.

Optional

## MEASURING TOUCH PROBE



RENISHAW RMP 60



HEIDENHAIN TT160



HEIDENHAIN SE G8D/TTASO/TS 480

## SAFETY COVER & FENCE

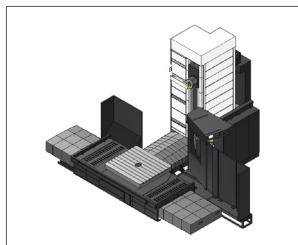

Standard

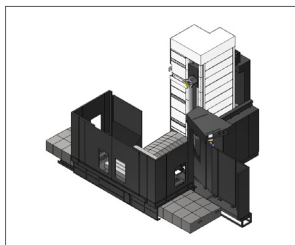

Opt. 1 Table around cover

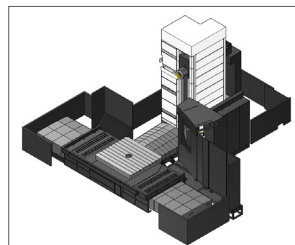

Opt. 2 Safety fence

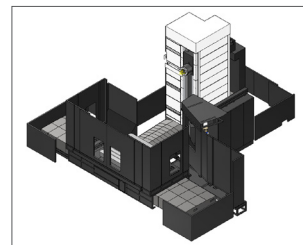

Opt. 3 Table around cover &  
Safety fence

## SPECIAL HEAD

### Angle Head (Manual)

Angle head comes with rotary body, which enables machining items that are set perpendicular to the spindle.

It is connected to arbors that transfer the torque generated from the main spindle motors.

### Facing Head (Manual)

A facing head is attached to the cross section of the spindle for various types of operations: outer facing, inner facing, cylindrical and conical boring and threading etc. It shows excellent performance in machining parts such as flange faces of large valves.

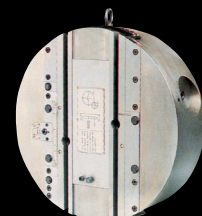
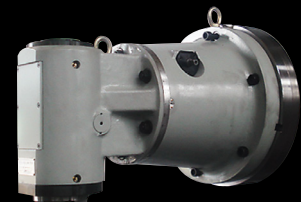

# SPECIFICATIONS

## Standard & Optional

Spindle		KBN1300C
2,500rpm (37kW [50HP])	FANUC	●
2,500rpm (45kW [60HP])	FANUC	○
Spindle Cooling System		●
W Axis Support Sleeve		○
ATC		
ATC Extension	60T	●
	90T	○
Tool Shank Type	BT50	●
	BBT50	○
	CAT50	○
	DIN50	○
Heavy Weight Tool	30kg (66lb)	●
U-Center	D'andrea	☆
Pull Stud	45°	●
	60°	☆
	90°	☆
Facing Head		○
Facing Tool Holder (Facing heads when applying)		○
Telescopic Tool Holder (Facing heads when applying)		○
Angle Head	500mm(19.7")	○
	800mm(31.5")	○
Compact Head		○
Universal Head		○
Table & Column		
Maximum Load Capacity	15t (33,069lb)	●
	20t (44,092lb)	○
T-Slot Table		●
B Axis Table	0.001°	●
X Axis Extension	4,000mm(157.4")	○
Y Axis Extension	2,500mm(98.4")	○
Z Axis Extension	2,000mm(78.7")	○
Table Auto Clamp Device	Hyd. Brake Pad	●
Coolant & Air Blow		
Coolant Device		○
Through Spindle Coolant*	30bar (435psi)	○
	50bar (725psi)	○
Gun Coolant (Only for Coolant Device)		○
Air Gun		○
Cutting Air Blow		○
Tool Measuring Air Blow (Only for TLM)		○
Coolant Chiller (Only for Coolant Device)		☆
Coolant Level Sensing		○
Chip Disposal		
Coolant Tank	515 ℓ (136 gal)	○
Internal Screw Chip Conveyor		●
Chip Conveyor (Hinge/Scraper) -Only for Coolant Device	Left(Front)	○
	Left(Rear)	○
Chip Wagon	Standard (180 ℓ [47.5 gal])	○
	Swing (200 ℓ [52.8 gal])	○
	Large Swing (290 ℓ [76.6 gal])	○
	Large Size (330 ℓ [87.2 gal])	○
	Customized	☆
Safety Device		
Front Full Cover		●
Table Around Cover (Only for Thru. Coolant)		○
Extension Table Around Cover		☆
Safety Fence		○

● : Standard ○ : Option ☆ : Prior Consultation - : Non Applicable

Electric Device		KBN1300C
Call Light	1 Color : ●	●
Call Light & Buzzer	3 Color : ● ● ●	○
Work Light		●
Electric Cabinet Light		●
Remote MPG		●
3 Axis MPG		●
Work Counter	Digital	●
Total Counter	Digital	○
Tool Counter	Digital	○
Multi Tool Counter	6 EA	☆
	9 EA	☆
Electric Circuit Breaker		○
AVR (Auto Voltage Regulator)		☆
Transformer	90kVA	○
Auto Power Off		○
Back up Module for Black out		○
Measurement		
TLM (Marposs/Renishaw/Blum)	Touch	○
	Laser	○
Tool Broken Detective Device		☆
Linear Scale	X/Y/Z Axis	●
Rotary Scale	B Axis	●
Environment		
Air Conditioner		○
Dehumidifier		○
Oil Mist Collector		☆
Oil Skimmer (Only for Chip Conveyor)		○
MQL (Minimal Quantity Lubrication)		☆
Fixture & Automation		
Sub O/P		-
Control of Additional Axis	1Axis	☆
	2Axis	-
External M Code 4ea		○
I/O Extension (In & Out)	16 Contact	☆
Workpiece Ejection Device	32 Contact	☆
Hyd. Device		
Std. Hyd. Unit	30 ℓ (7.9 gal)	●
Center Hyd. Supply Device		-
Hyd. Unit for Fixture	45bar	☆
	70bar	☆
	100bar	☆
	Customized	☆
I/C		
FANUC 31i-B PLUS		●
SIEMENS SINUMERIK ONE		-
HEIDENHAIN iTNC 640		-
ETC		
Tool Box		●
CAD&CAM Software		☆
Customized Color	Need for Munsel No.	☆
W Axis Clamp Device		●
Y Axis Clamp Device		●
Thermal displacement compensation		○

Through Spindle Coolant\* : Please check the filter types with sales representative.

\*Specifications are subject to change without notice for improvement.



# SPECIFICATIONS

## Special Head Dimensions

unit : mm(in)

**Spindle Support  
Ø130**

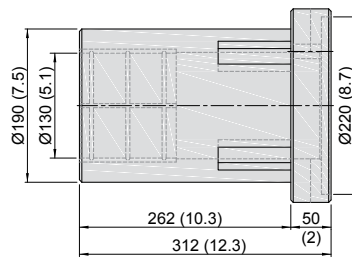

**Right Angular Head  
Ø130**

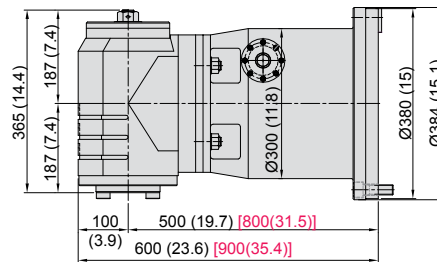

**Compact Angle Head  
Ø130**

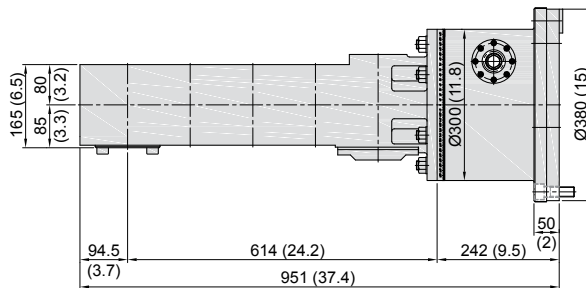

**Universal Head  
Ø130 (Manual)**

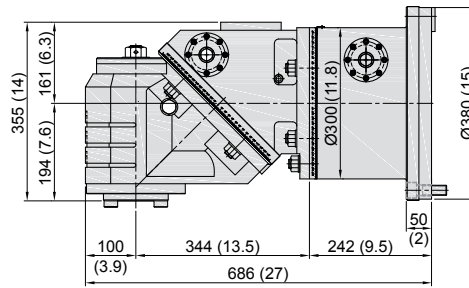

**Face Plate  
(Manual)**

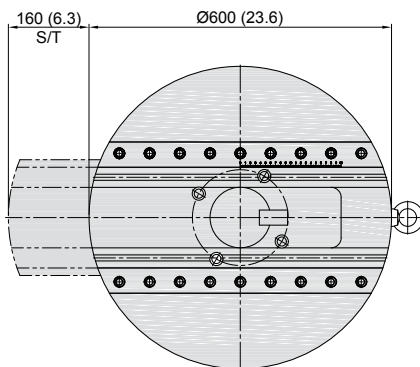

**Facing Head (Auto)  
(D'ANDREA)**

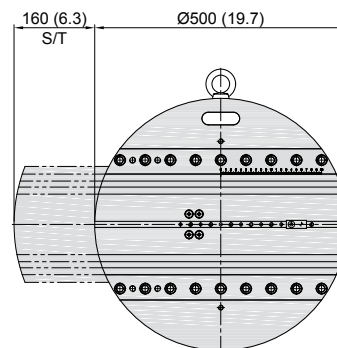

# SPECIFICATIONS

## Table Dimensions

unit : mm(in)

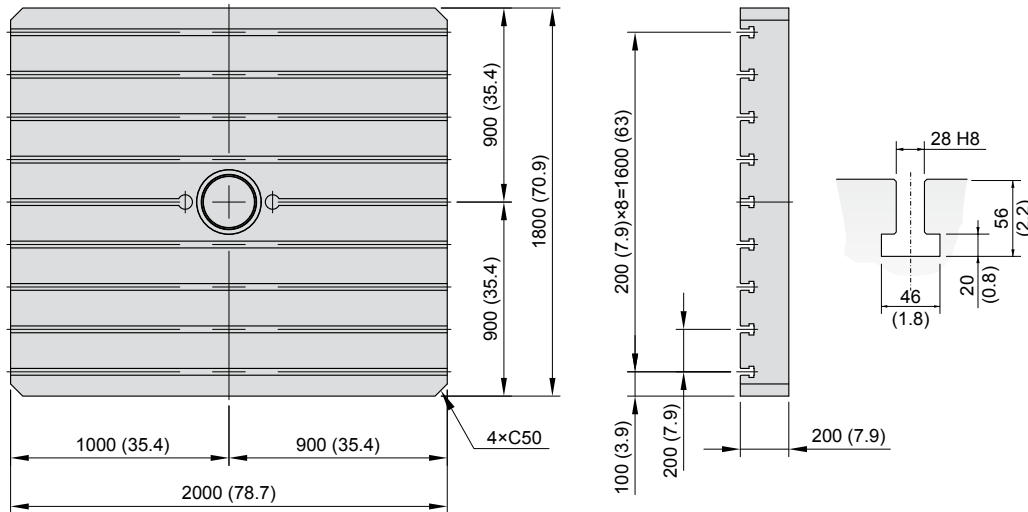

## Tool Shank

unit : mm

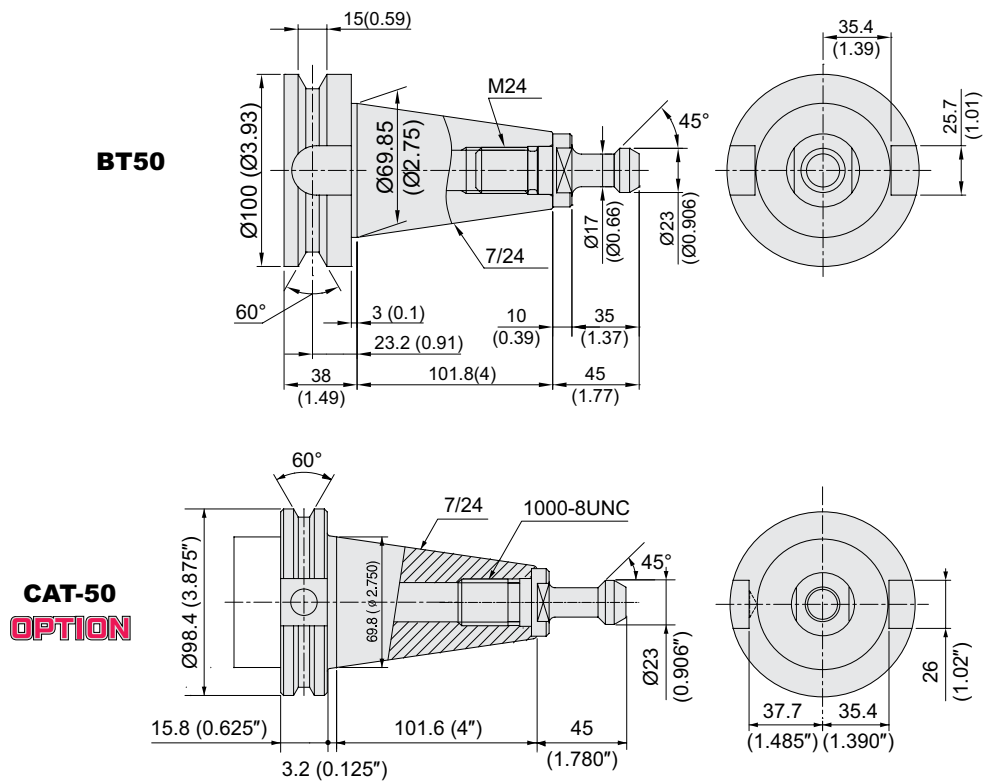

\*Specifications are subject to change without notice for improvement.

# SPECIFICATIONS

## Specifications

[ ] : Option

ITEM		KBΠ1300C		
TABLE	Table Size	mm(in)	2,000×1,800 (78.7"×70.9")	
	Maximum Load Capacity	kgf(lb)	15,000 (33,069) [20,000(44,092)]	
	Min. Indexing Angle	deg	0.001°	
SPINDLE	Boring Spindle	mm	Ø130 (5.1")	
	Spindle Taper	-	BT50	
	Spindle Speed (rpm)	r/min	2,500 [2,500]	
	Spindle Power (Max./Cont.)	kW(HP)	37/30 (50/40) [45/37 (60/50)]	
	Spindle Torque(Max./Cont.)	N·m(lbf·ft)	3,377/2,739 (2,491/2,020) [4,191/3,377 (3,091/2,491)]	
	Spindle Driving Method	-	2 STEP GEAR BOX (ZF reducer)	
FEED	Travel	X-axis	mm(in)	3,000 (118.1") [4,000 (157.5")]
		Y-axis	mm(in)	2,000 (78.7") [2,500 (98.4")]
		Z-axis	mm(in)	1,500 (59.0") [2,000 (78.7")]
		W-axis	mm(in)	700 (27.6")
	Distance from Table Surface to SP. Center	mm(in)	0 ~ 2,500 (98.4")	
	Distance from Table center to SP. Nose	mm(in)	800 ~ 2,300 (31.5" ~ 90.5") [800 ~ 2,800 (31.5" ~ 110.2")]	
	Rapid Traverse Rate (X/Y/Z/W)	m/min(ipm)	10/10/10/8 (393/393/393/315)	
	Slide Type	-	BOX GUIDE	
ATC	Number of Tools	EA	60 [90]	
	Tool Shank	-	BT50	
	Max. Tool Dia. (W.T/W.O)	mm(in)	Ø125/Ø250 (4.9"/9.8")	
	Max. Tool Length	mm(in)	600 (23.6")	
	Max. Tool Weight	kg(lb)	30 (66.1)	
	Tool Change Time	C-C	sec	30
	Max. tool moment	N·m(lbf·ft)	34 (25.1)	
POWER	Required Power Capacity	kVA	81	
MACHINE	Floor Space (L×W)	mm(in)	6,446 x 8,180 (253.8" x 322.0") [8,720 x 8,880 (343.3" x 349.6")]	
	Height	mm(in)	5,080 (200.0") [5,580 (219.7")]	
	Weight	kg(lb)	48,000 (105,822") [52,000 (114,640")]	
PC	Controller	-	FANUC 31i-B Plus	

\*Specifications are subject to change without notice for improvement.



# CONTROLLER

## FANUC 31i-B Plus

[ ] : Option ☆ Needed technical consultation

Control Axis	
Controlled axes	5 axis (X, Y, Z, W, B)
Simultaneously controllable axes	Positioning(G00)
	Linear interpolation(G01) : 3axes
	Circular interpolation(G02, G03) : 2axes
Backlash compensation	
Emergency stop / overtravel	
Follow up	
Least command increment	0.001mm / 0.0001 (inch)
Least input increment	0.001mm / 0.0001 (inch)
Machine lock	All axes / Z axis
Mirror image	Reverse axis movement (setting screen and M - function)
Stored pitch error compensation	Pitch error offset compensation for each axis
Stored stroke check 1	Overtravel controlled by software
Compensation and Feed Function	
2nd reference point return	G30
AI Contour Control II	200 block preview
Automatic corner deceleration	
Circular interpolation	G02, G03
Control axis detach	
Dual position feedback	
Dwell	G04
Exact stop check	G09, G61(mode)
Feed per minute	mm / min
Feedrate clamp by circular radius	
Feedrate override (10% increments)	0 - 200%
Helical interpolation	
Jog feedrate	0~5000mm / min
Linear ACC/DEC after interpolation	
Linear ACC/DEC before interpolation	
Linear interpolation	G01
Manual handle feed(1unit)	
Manual handle feedrate	0.1 / 0.01 / 0.001mm
Override cancel	M48 / M49
Positioning	G00
Program restart	
Rapid traverse bell-shaped acceleration / deceleration	
Rapid traverse override	F0 (fine feed), 25 / 50 / 100%
Reference point return	G27, G28, G29
Skip function	G31
Smooth backlash compensation	
Thread cutting, synchronous cutting	
Handle interruption	
High speed skip function	
Spindle and M Code Function	
M - code function	M3 digits
Polar coordinate interpolation	G12.1 / G13.1
Retraction for rigid tapping	
Rigid tapping	G84, G74
Scaling	G50, G51
Spindle orientation	
Spindle output switching	
Spindle serial output	
Spindle speed command	S5 digits
Spindle speed override (10% increments)	10 - 150%
TOOL Function	
Tool offset B	G43, G44, G49
Tool life management	Geometry / Wear and Length / Radius offset memory
Tool number command	T3 digits
Tool offset memory C	
Tool offset pairs	200 ea
Tool offset	G45 - G48
Programming and Edit Function	
Absolute / Incremental programming	G90 / G91
Addition of custom macro common variables	
Additional work coordinate system(48 Pair)	G54.1 P1 - 48 pairs
Auto.Coordinate system setting	
Background editing	
Canned cycle	G73, G74, G76, G80 - G89, G99

Programming and Edit Function	
Circular interpolation by radius programming	
Coordinate system rotation	G68, G69
Custom macro	
Increment system 1/10	
Decimal point input	
Extended part program editing	
I / O interface	USB / Ethernet
Inch / metric conversion	G20 / G21
Label skip	
Local / Machine coordinate system	G52 / G53
Maximum commandable Demension	+99999.999mm(+9999.9999 inch)
No. of Registered programs	1000 ea
Optional angle chamfering / corner R	
Optional block skip	
Optional stop	M01
Part program storage size	4Mbyte(10,240 m)
Program number	04 - digits
Program protect	
Program stop / end	M00 / M02, M30
Programmable data input	Tool offset and work offset are entered by G10, G11
Sub program	Up to 4 nesting
Tape code	ISO / EIA Automatic discrimination
Work coordinate system	G54 - G59
OTHERS FUNCTIONS (Operation, Setting & Display, etc)	
Alarm display	
Alarm history display	
Clock function	
Cycle start / Feed hold	
Display of PMC alarm message	Message display when PMC alarm occurred
Dry run	
Ethernet function (Embedded)	
External data input	
Graphic display	Tool path drawing
Help function	
MDI / DISPLAY unit	15" Color LCD, Touchscreen
Memory card interface	
Multi language display	
Operation functions	Tape / Memory / MDI / Manual
Operation history display	
Program restart	
Run hour and part number display	
Search function	Sequence NO. / Program NO.
Self - diagnostic function	
Servo setting screen	
Single block	
Optional Function	
3 - dimensional coordinate conversion	
3 - dimensional tool compensation	
Addition of tool pairs for tool life management	1024 pairs
Additional controlled axes	max. 6 axes in total
Additional work coordinate system	G54.1 P1 - 300 (300 pairs)
AI Contour Control II	600 block preview
Automatic corner override	G62
Chopping function	G81.1
Cylindrical interpolation	G07.1
Data server	
Dynamic graphic display	Machining profile drawing
Exponential interpolation	
Figure copying	G72.1, G72.2
Interpolation type pitch error compensation	
Involute interpolation	G02.2, G03.2
Machining time stamp function	
Manual handle feed 2/3 unit	
No. of Registered programs	4000 ea
Number of tool offsets	499 / 999 / 2000 ea
Part program storage size	8Mb (20480m)
Polar coordinate command	G15 / G16
Programmable mirror image	G50.1 / G51.1
Single direction positioning	G60



**You Tube** HYUNDAI WIA MT  
[www.youtube.com/HYUNDAIWIAMT](http://www.youtube.com/HYUNDAIWIAMT)

# CREATING VALUE IN SEAMLESS MOBILITY

With its top-quality HYUNDAI WIA machine tool creates a new and better world.



<http://machine.hyundai-wia.com>  
HYUNDAI WIA Machine Tools  
Global Links