

KH

1000

Robust Machining Center with Revolutionary Productivity

HYUNDAI WIA Heavy Duty Horizontal Machining Center

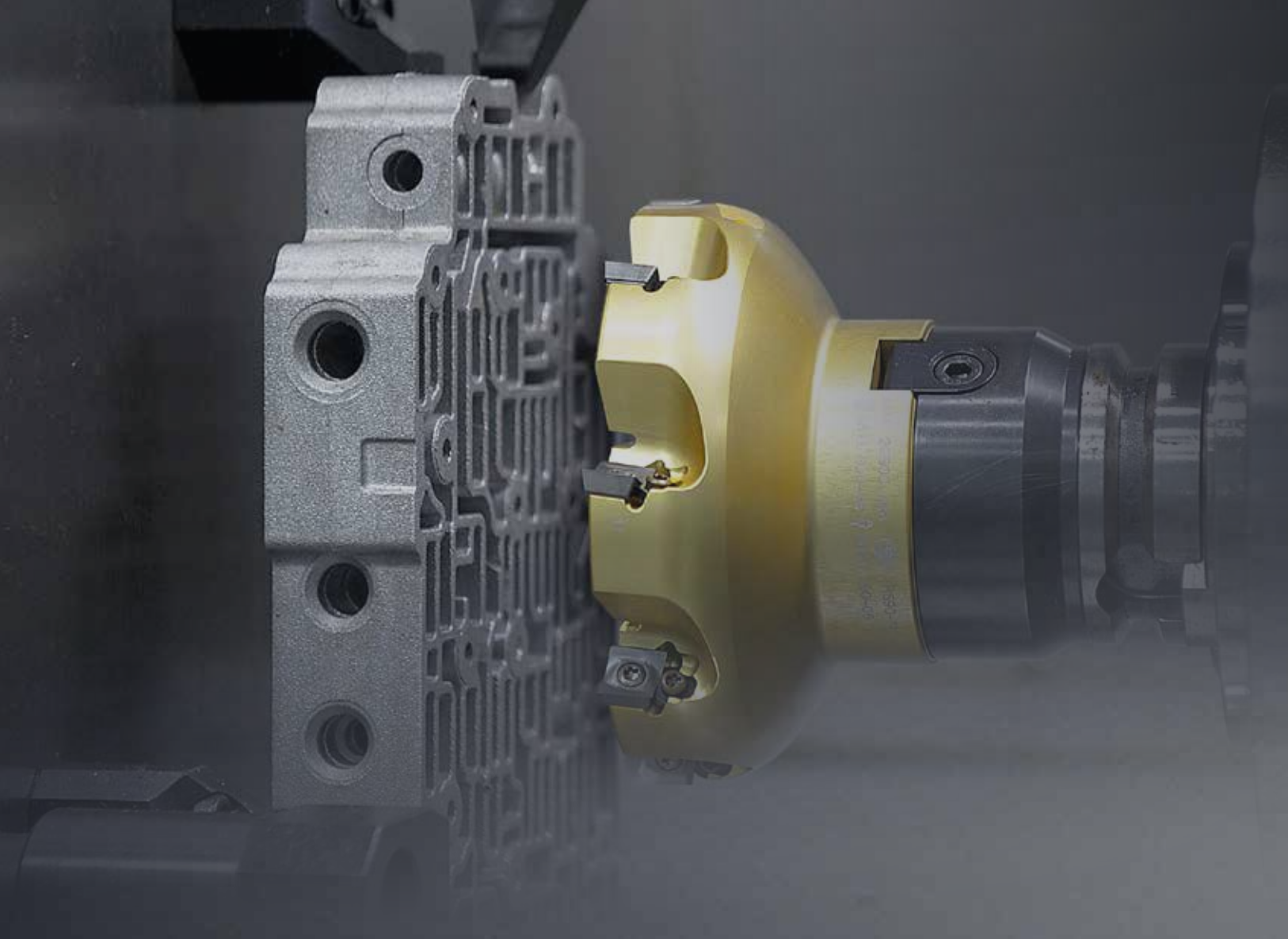

Technical Leader

Resulting from years of experience, Hyundai WIA's KH1000 features a 2 step geared spindle, rigid construction and spacious work area.

This powerful horizontal machining center delivers accurate machining and maximum productivity.

KH1000

Pallet Size (L×W)	mm(in)	2-1,000×1,000 (2-39.4"×39.4")
Max. Load Capacity	kg(lb)	2-3,000 (2-6,614)
Spindle Taper	-	BBT50
Spindle Speed	r/min	8,000 [4,500] [8,000] [12,000]
Spindle Output	kW(HP)	26/22 (35/30) [26/22 (35/30)] [26/22 (35/30)] [30/25 (40/33.5)]
No. of Tools	EA	60 [90, 120]
Travel (X/Y/Z)	mm(in)	2,100/1,350/1,400 (82.7"/53.1"/55.1")
Rapid Traverse Rate (X/Y/Z)	m/min(ipm)	20/20/20 (787/787/787)

[] : Option • SIEMENS

KH

1000

Heavy Duty Cutting Horizontal Machining Center

- Best in Class Max. Work Size of $\varnothing 1,900\text{mm}$ ($\varnothing 74.8''$) & $1,500\text{mm}$ ($59.1''$) Height
- High torque Spindles of 8,000rpm and 4,500rpm
- BBT50 Dual Contact Spindle for High Rigidity
- Spindle Oil Cooling Device for High Accuracy
- Shuttle Type APC
- Box Guideways on All Axis for Ultra-Rigidity
- 8-face Contact Y-axis Guideway
- Specially Designed Column That Minimize Thermal Displacement

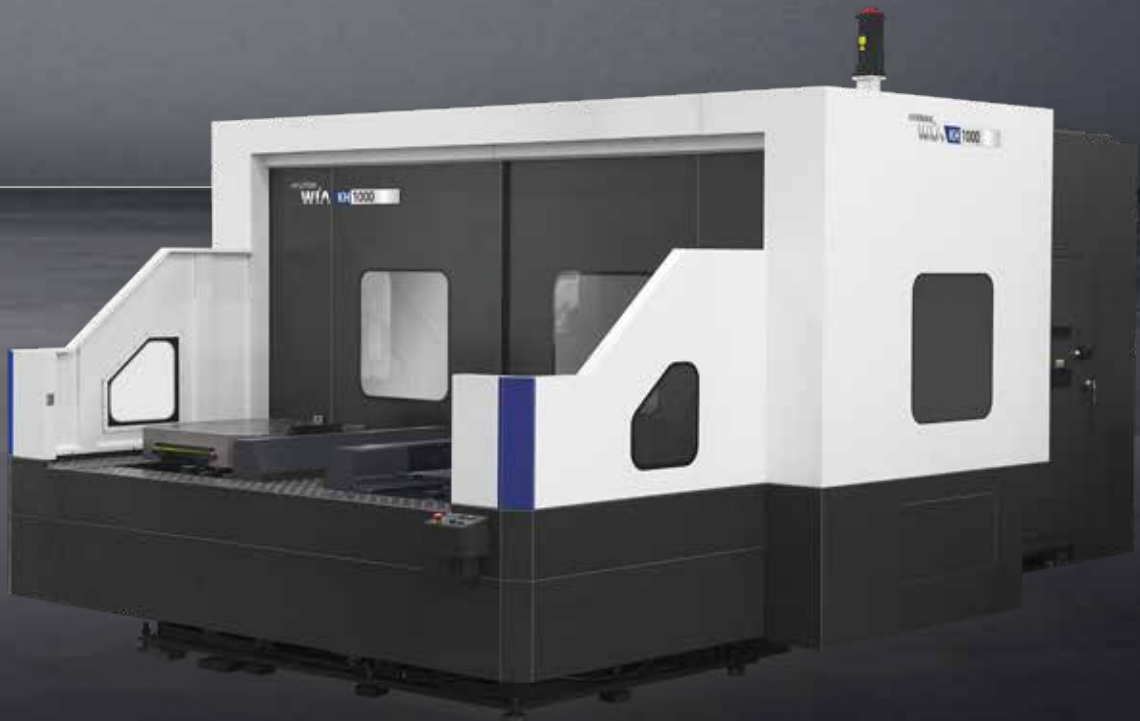

01 BASIC STRUCTURE

Heavy Duty Cutting & Productivity Horizontal Machining Center

ATC & Magazine

- No. of Tools : 60 [90/120] EA
- Tool Selection Method : Fixed

High Precision Spindle

- 2 Step Gear Type : 8,000 r/min
- 3 Step Gear Type : 4,500 r/min (Opt.)
- Built-in : 12,000 r/min (Opt.)
- Oil Cooling System
- BBT50

Pallet

- Pallet Size (L×W) :
1,000×1,000 mm (39.4"×39.4")
- APC Type : Shuttle

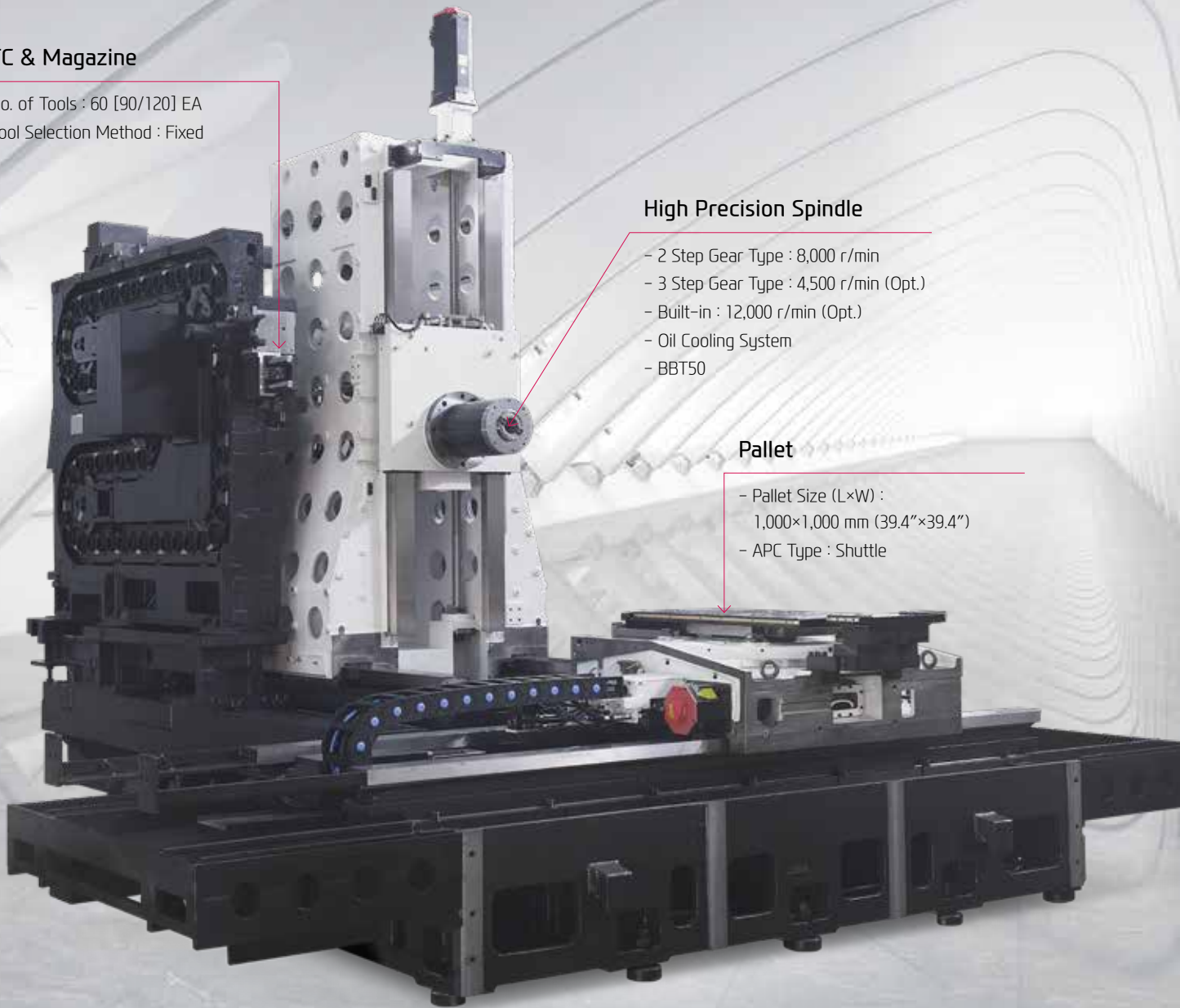

HIGH RIGIDITY, HIGH PERFORMANCE

HIGH RIGIDITY STRUCTURE

Column Moving Structure

The column moving Z-axis prevents table sagging when loading or machining.

Also, double-wall structure of the column minimizes thermal displacement and maximizes cutting force from X-axis which provides excellent performance in heavy duty cutting.



Floor Space (L×W)

5,095×8,775 (60 Tool) mm (200.6"×345.5")

GUIDE WAY

Box Guideway for All Axis

Box guideways effectively offset vibration from travel axis enabling the machining of high precision products.

Air Semi-Rising Slideway

By applying the air semi-rising slideways, the load on the Z-axis slideway is decreased. Therefore, positioning and repeatability accuracy can be maintained for a long time.

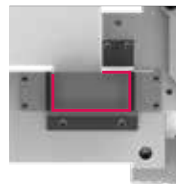
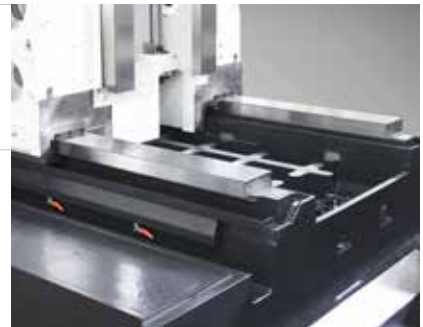

8-Face Contact Y-axis Guideway

Spindle head contacts 8 faces of Y-axis guideway. This new method allows cutting forces generated by the spindle head to be absorbed by the Y-axis box guideways which improves heavy duty cutting ability, accuracy, and surface finish.

Travel (X/Y/Z)

2,100/1,350/1,400 mm

Rapid Traverse Rate (X/Y/Z)

20/20/20 mm

02 HIGH PRECISION SPINDLE

Excellent machining performance with high-precision spindle

Spindle Specifications

[] : Option

Speed (rpm)	Motor (Max./Cont.)	Torque (Max./Cont.)	Driving Method
8,000 r/min (FANUC)	26/22 kW (35/30HP)	807/686 N·m (595.2/506 lbf·ft)	2 Step Gear
[4,500 r/min (FANUC)]	[26/22 kW (35/30HP)]	[3,234/2,744 N·m (2,385.3/2,023.8 lbf·ft)]	[3 Step Gear]
[8,000 r/min (SIEMENS)]	[26/22 kW (35/30HP)]	[1,007/818 N·m (742.7/603.3 lbf·ft)]	[2 Step Gear]
[12,000 r/min (FANUC)]	[30/25 kW (40/33.5HP)]	[420/238 N·m (309.8/175.5 lbf·ft)]	[Built-in]

Machining Capability



FACE MILL (Material : SM45C)

Tool Diameter	Ø125 mm (Ø4.921")
Spindle Speed	600 r/min
Feed Rate	1,134 mm/min (44.6 ipm)
Cutting Width	100 mm (3.94")
Cutting Depth	6 mm (0.236")

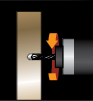

DRILL (Material : SM45C)

Tool Diameter	Ø60 mm (Ø2.36")
Spindle Speed	143 r/min
Feed Rate	21 mm/min (0.826 ipm)

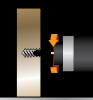

TAP (Material : SM45C)

Tool Diameter	M52×P5.0
Spindle Speed	42 r/min
Feed Rate	210 mm/min (8.27 ipm)

❖ The above results might be different by types of processing circumstances.

HIGH-PERFORMANCE, HIGH-PRECISION SPINDLE

SPINDLE

Gear Driven Spindle

KH1000 is designed with a 2 step gear driven spindle(3 step gear driven spindle:Option), which provides high torque at low rpm and stability at high rpm. The AC spindle motor with max. power of 26kW(35HP) and max. speed of 8,000rpm is suitable for heavy duty cutting and high speed machining. The spindle's oil cooling system is designed to minimize thermal displacement.



2 Step Gear

Built-in Spindle

By using ultra precision class angular ball bearings, fast acc/ deceleration of the main spindle is achieved. The spindle head is designed to minimize heat displacement therefore reducing heat generation and making it possible to maintain high accuracy.

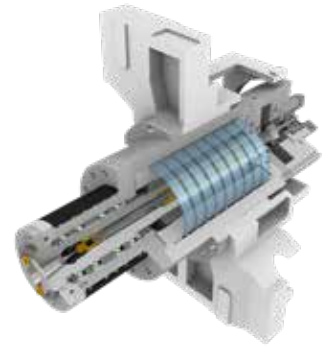

Built-in

Spindle Cooling

Spindle temperature can be controlled by the use of a spindle oil chiller. this ensures constant oil temperature and minimizes thermal displacement.

Dual Contact Spindle

The Big Plus spindle system (BBT) provides dual contact between the spindle face and the flange face of the tool holder.

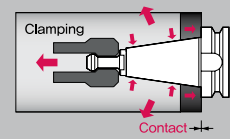

- ❖ The increase in standard diameter improves stiffness and ATC repeatability, and Z-axis displacement is prevented which further extends tool life.

THROUGH SPINDLE COOLANT OPTION

Through Spindle Coolant is exceedingly useful when drilling deep holes. It helps increase the lifetime of the tool, while decreasing cycle time.



20 bar / 30 bar / 70 bar

03 APC & ATC

High Productivity Achieved with High Rigidity, Accuracy Machining

⊙ Tap Pallet

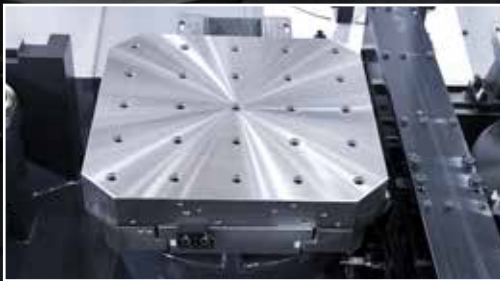

⊙ T-Slot Pallet **OPTION**



APC & Pallet Specifications

[] : Option

Model	Pallet Size (L×W)	Max. Load Capacity	Min. Indexing Angle	APC Type
KH1000	1,000×1,000 mm (39.4"×39.4")	3,000 kg (6,614 lb)	1° [0.001°]	SHUTTLE

ATC & Magazine Specifications

Model	No. of Tools	Max. Tool Dia. (W.T/W.O)	Max. Tool Length	Max. Tool Weight
KH1000	60 [90, 120] EA	Ø110/Ø245 mm (Ø4.3"/Ø9.6")	600 mm (23.6")	35 kg (77.2 lb)

HIGH RIGIDITY, TOOL & PALLET CHANGE SYSTEM

APC & PALLET

Shuttle Type APC

The KH1000 is equipped with a shuttle type APC (Automatic Pallet Changer) as standard.

The powerful clamping by clamping plate is suitable for heavy duty cutting.

B Axis Index Angle Std. : 1° [Opt. : 0.001°]

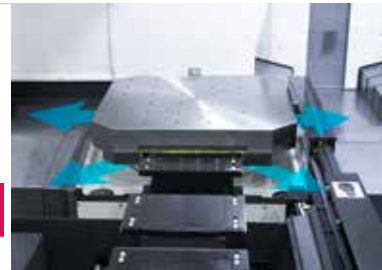

Air Clearing System

During the pallet change cycle, strong air blasts from the taper cones on the machine table helps remove chips to provide clean surface for locating the pallet. This ensures high accuracy of pallet positioning and guarantees optimum rigidity.

Pallet Brush

Pallet brush is added to remove chip during pallet change.

ATC & MAGAZINE

KH1000 offers various tool magazines which expand the range of machining. Also, fixed address tool selection method and 2 types of ATC cycles: for heavy tools and standard tools, increase convenience.

ATC Air Blow & Brush

Tool Holders are automatically cleaned by an air blow and brush when they are placed in the standby position.



60 Tool

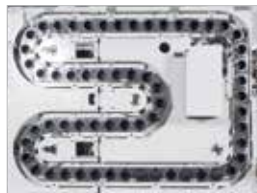

90 Tool **OPTION**

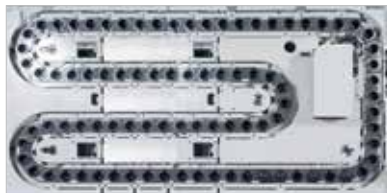

120 Tool **OPTION**



Machine Dimensions According to Magazine Selection

60 Tool	90 Tool	120 Tool
9,440 mm (371.7")	9,765 mm (384.4")	10,076 mm (396.7")

SPECIFICATIONS

Standard & Optional

		KH1000
Spindle		
4,500rpm (FANUC)	3 Step Gear	○
8,000rpm (FANUC)	2 Step Gear	●
8,000rpm (SIEMENS)	2 Step Gear	○
12,000rpm (FANUC)	Built-in	○
Spindle Cooling System		●
ATC		
	60	●
	90	○
	120	○
	BT50	-
Tool Shank Type	BBT50	●
	BCV50	○
Heavy Weight Tool	20kg (44lb)	-
	35kg (77.2lb)	●
U-Center	D'andrea	☆
	45°	●
Pull Stud	60°	○
	90°	○
Servo Motor Magazine		☆
Table & Column		
APC	Shuttle	●
Tap Type Pallet		●
T-Slot Pallet		○
Std. Table		○
B Axis NC Table	1°	●
B축 NC테이블	0.001°	○
Coolant System		
Std. Coolant (Nozzle)		●
Bed Flushing Coolant		-
	20 bar	○
Through Spindle Coolant*	30 bar, 20 ℓ (5.3 gal)	○
	70 bar, 15 ℓ (3.9 gal)	○
Shower Coolant		○
Gun Coolant		○
Side Oil Hole Coolant		☆
Air Gun		○
Cutting Air Blow		○
Tool Measuring Air Blow (Only for TLM)		○
Air Blow for Automation		☆
Thru MQL Device (Without MQL)		☆
Coolant Chiller		☆
Power Coolant System (For Automation)		☆
Chip Disposal		
Coolant Tank	770 ℓ (203.4 gal)	●
Cabin Screw Chip Conveyo		●
Chip Conveyor (Hinge/Scraper/Magnetic)	Left(Front)	-
	Left(Rear)	○
Special Chip Conveyor (Drum Filter)		☆
Chip Wagon	Standard (180 ℓ [47.5 gal])	○
	Swing (200 ℓ [52.8 gal])	○
	Large Swing (290 ℓ [76.6 gal])	○
	Large Size (330 ℓ [87.2 gal])	○
	Customized	☆
Safety Device		
Total Splash Guard		●
APC Splash Guard		-
ETC		
Tool Box		●
Customized Color	Need for Munsel No.	☆
CAD&CAM Software		☆
Air Lift Slide Method	Z Axis	●

● : Standard ○ : Option ☆ : Prior Consultation - : non applicable

		KH1000
Electric Device		
Call Light	1 Color : ●	●
Call Light & Buzzer	3 Color : ● ● ● B	○
Work Light		●
Electric Cabinet Light		○
Remote MPG		●
3 Axis MPG		○
Work Counter	Digital	○
Total Counter	Digital	○
Tool Counter	Digital	○
Multi Tool Counter	6 EA	☆
	9 EA	☆
Electric Circuit Breaker		○
AVR (Auto Voltage Regulator)		☆
Transformer	60KVA	○
Auto Power Off		○
Back up Module for Black out		○
Back up Module for Black out - Extension (FANUC : PFB-R/C)		☆
Measuring Device		
Air Zero	TACO	☆
	SMC	☆
Work Measuring Device		○
TLM (Marposs/Renishaw/Blum)	Touch	○
	Laser	☆
Tool Broken Detective Device		☆
Linear Scale	X/Y/Z Axis	○
Rotary Scale	B Axis	☆
Pallet Close Confirmation Device		☆
Coolant Level Sensor (Only for Chip Conveyor, Bladder Type)		☆
Environment		
Air Conditioner		○
Dehumidifier		○
Oil Mist Collector		☆
Oil Skimmer (Only for Chip Conveyor)		●
MQL (Minimal Quantity Lubrication)		☆
Fixture & Automation		
Sub O/P		☆
Control of Additional Axis	1 Axis / Pallet	☆
External M Code 4ea		○
Automation Interface		☆
I/O Extension (In & Out)	16Contact	☆
	32Contact	☆
PPL (6PPL)		☆
Hyd. Device		
Std. Hyd. Unit	50bar/ 60 ℓ (16.9 gal)	●
Manual Coupler	2x2(4Port)	☆
Auto Coupler		☆
Hyd. Unit for Fixture	45bar	○
	70bar	○
	100bar	☆
	Customized	☆
S/W		
Dialogue Program (HW-DPRO)		○
DNC software (HW-eDNC)		○
Machine Monitoring System (HW-MMS Cloud)		☆
Smart Guide-i : FANUC		☆
Smart S/W		☆

Through Spindle Coolant* : Please check the filter types with sales representative.

Specifications are subject to change without notice for improvement. / Please refer to the S/W catalog (iRIS) for details by S/W product.

SPECIFICATIONS

Spindle Output/Torque Diagram

8,000rpm (2 Step Gear)

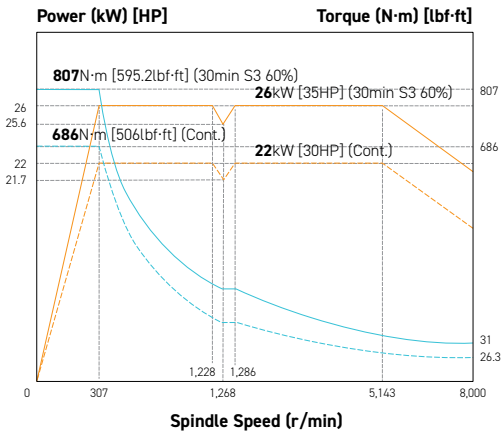

8,000rpm (2 Step Gear)

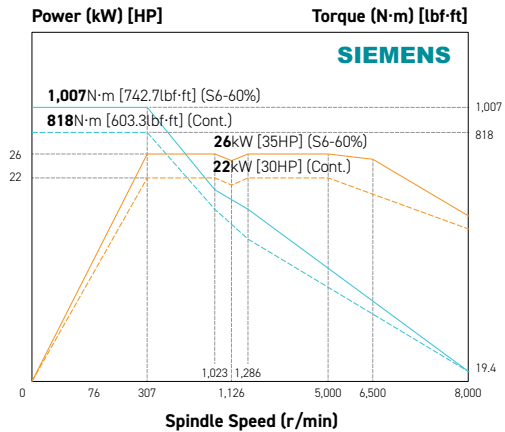

4,500rpm (3 Step Gear)

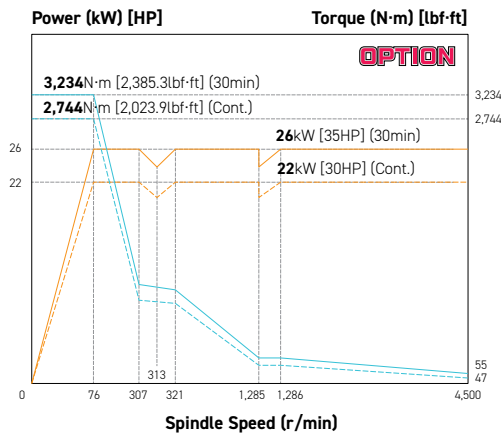

12,000rpm (Built-in)

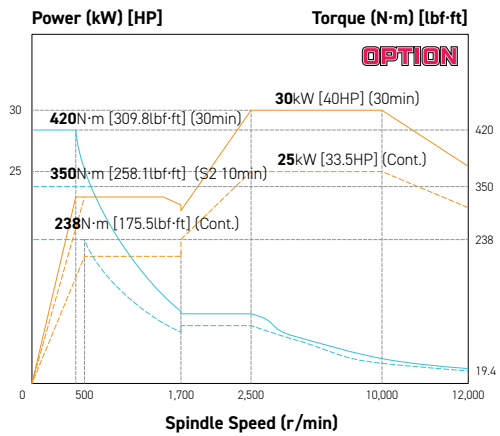

Tool Shank

unit : mm

BT50/BBT50, BIG PLUS

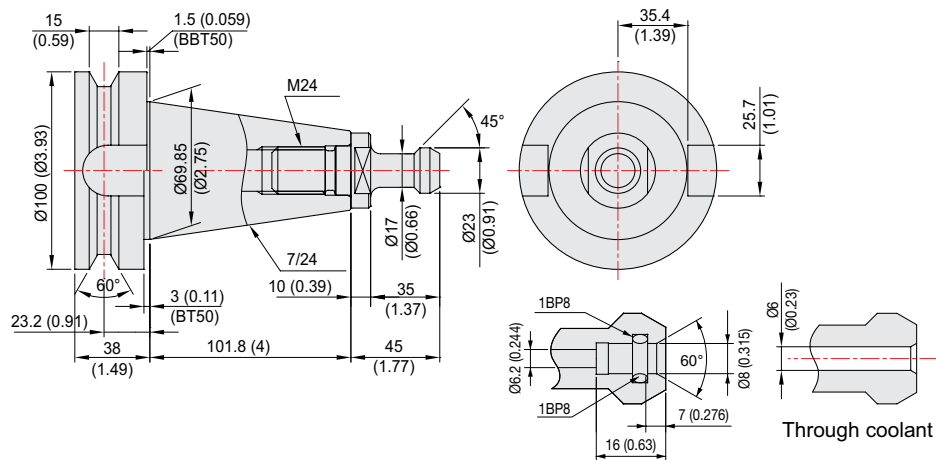

SPECIFICATIONS

External Dimensions

unit : mm(in)

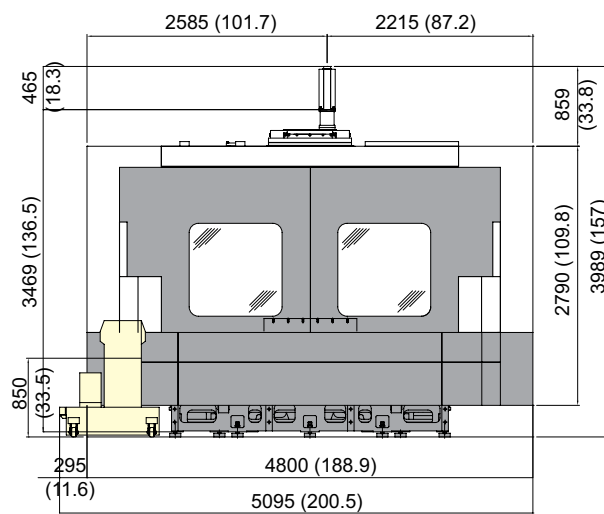
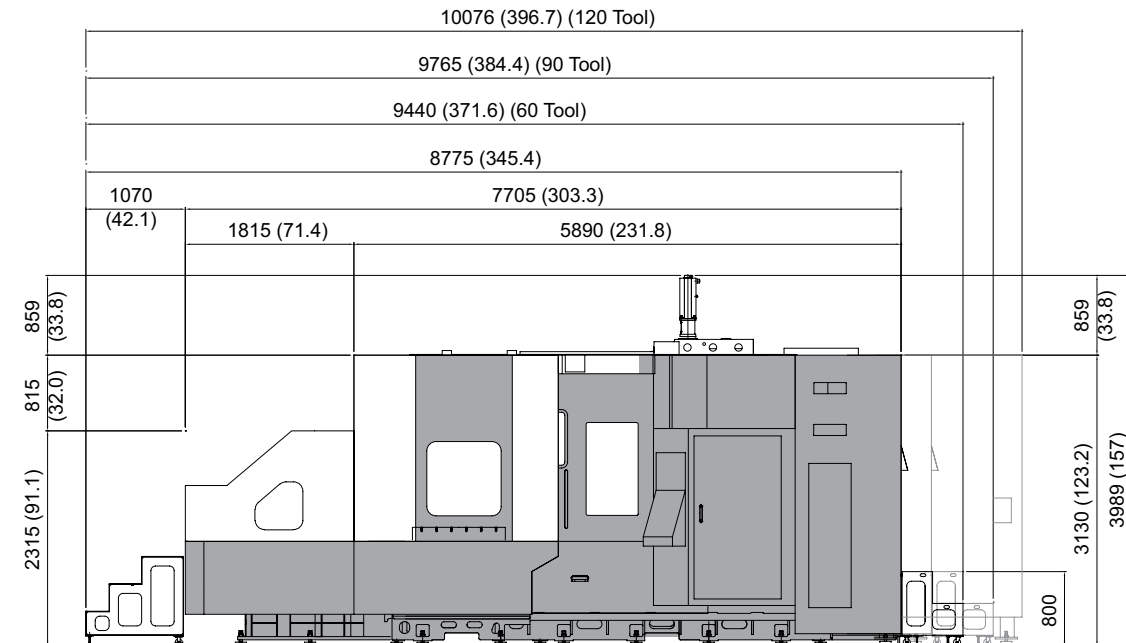

SPECIFICATIONS

Table Dimensions

unit : mm(in)

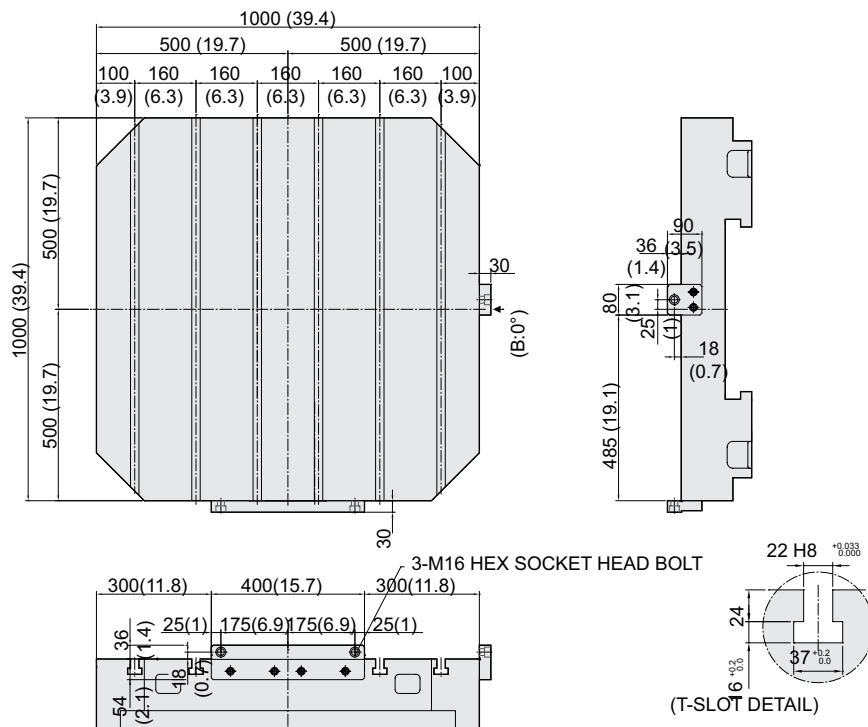
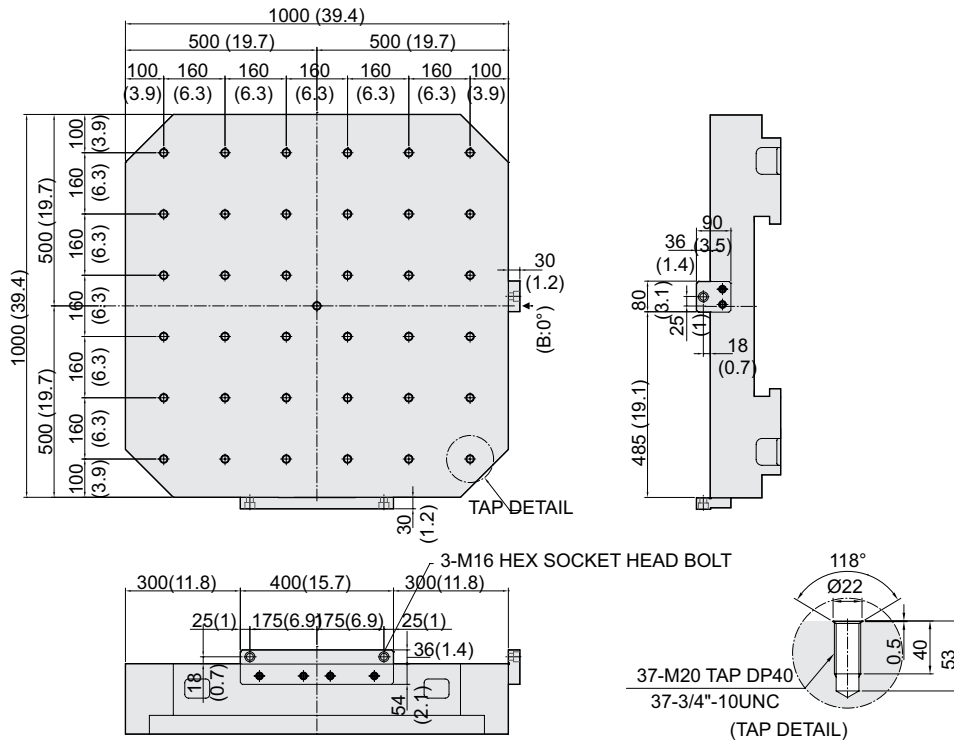

SPECIFICATIONS

Specifications

[] : Option

ITEM		KH1000				
PALLET	Pallet Size	mm(in)	2-1,000×1,000 (2-39.4"×39.4")			
	Maximum Load Capacity	kg(lb)	2-3,000 (2-6,614)			
	Maximum Working Size	mm(in)	Ø1,900×H1,500 (Ø74.8"×H59.1")			
	Min. Indexing Angle	deg	1° [0.001°]			
SPINDLE	Spindle Taper	-	BBT50 [BCV50]			
	Spindle RPM	r/min	8,000	[4,500]	[8,000]	[12,000]
	Spindle Motor Output (Max./Cont.)	kW(HP)	26/22 (35/30)	[26/22 (35/30)]	[26/22 (35/30)]	[30/25 (40/33.5)]
	Spindle Torque (Max./Cont.)	N·m(lbf.ft)	807/686 (595.2/506)	[3,234/2,744] (2,385.3/2,023.8)	[1,007/818] (742.7/603.3)	[420/238] (309.8/175.5)
	Spindle Driving Method	-	2 STEP GEAR	[3 STEP GEAR]	[2 STEP GEAR]	[BUILT-IN]
FEED	Travel (X/Y/Z axis)	mm(in)	2,100/1,350/1,400 (82.7"/53.1"/55.1")			
	Distance from Table Top to Sp. Center	mm(in)	0 ~ 1,350 (1"~53.2")			
	Distance from Table Center to Sp. Nose	mm(in)	300 ~ 1,700 (11.8"~66.9")			
	Rapid Traverse Rate (X/Y/Z)	m/min(ipm)	20/20/20 (787/787/787)			
	Slide Type	-	BOX GUIDE			
ATC	Number of Tools	EA	60 [90, 120]			
	Tool Shank	-	BBT50 [BCV50]			
	Max. Tool Dia. (W.T/W.O)	mm(in)	Ø110/Ø245 (Ø4.3"/Ø9.6")			
	Max. Tool Length	mm(in)	600 (23.6")			
	Max. Tool Weight	kg(lb)	35 (77.2)			
	Tool Selection Method	-	FIXED ADDRESS			
	Tool Change Time	T-T	sec	9		
C-C		sec	13			
APC	No. of Pallet	EA	2 [1]			
	Pallet Change Time	sec	110			
	APC Type	-	SHUTTLE			
TANK CAPACITY	Coolant Tank	ℓ(gal)	770 (203.4)			
	Lubricating Tank	ℓ(gal)	8.5 (2.2)			
	Hyd. Tank Unit	ℓ(gal)	60 (15.9)			
POWER SUPPLY	Air Consumption (0.5MPa)	ℓ/min(gal/min)	500 (132)			
	Electric Power Supply	KVA	46			
	Thickness of Power Cable	mm ²	OVER 50			
	Voltage	V/Hz	220/60 (200/50*)			
MACHINE	Floor Space (L×W)	mm(in)	5,095×8,775 (200.6"×345.5") (60 TOOL)			
	Height	mm(in)	3,989 (157")			
	Weight	kg(lb)	30,000 (66,139)			
NC	Controller	-	FANUC 31i-B Plus [SIEMENS 840D sl]			

*) Using 50Hz voltage instead of 60Hz may lower the output of motors. (excluding servo motors and inverter motors)
Specifications are subject to change without notice for improvement.

CONTROLLER

FANUC 31i-B Plus

[] : Option ☆ Needed technical consultation

Controlled axis / Display / Accuracy Compensation	
Control axis	4 axis (X, Y, Z, B)
Simultaneously controlled axis	3 axis [Max. 4 axis]
Least setting Unit	X, Y, Z axis : 0.001 mm (0.0001 inch) B axis : 1 deg [0.001] deg
Least input increment	X, Y, Z axis : 0.001 mm (0.0001 inch) B axis : 1 deg [0.001] deg
Inch / Metric conversion	G20 / G21
High response vector control	
Interlock	All axis / Each axis
Machine lock	All axis
Backlash compensation	± 0 ~ 9999 pulses (Rapid traverse / Cutting feed)
Position switch	
LCD / MDI	15" color LCD with Touch screen
Feedback	Absolute motor feedback
Stored stroke check 1	Over travel
Stored stroke check 2, 3	
Pitch error compensation	
Operation	
Automatic operation (Memory)	
MDI operation	
DNC operation	Needed DNC software / CF card
Program restart	
Wrong operation prevention	
Program check function	Dry run, Program check Z axis Machine lock, Stroke check before move
Single block	
Search function	Program Number / Sequence Number
Retraction for rigid tapping	
Manual guide i	Smart Guide i
Interpolation functions	
Nano interpolation	
Positioning	G00
Linear interpolation	G01
Cylindrical interpolation	G02, G03
Exact stop mode	Single : G09, Continuous : G61
One-way positioning	G60
Inverse-time feed	G93
Dwell	G04, 0 ~ 9999.9999 sec
Skip	G31
Reference position return	1st reference : G28 2, 3, 4 reference : G30 P2, P3, P4 Ref. position check : Z7
Thread synchronous cutting	G33
Helical interpolation	Circular + Linear interpolation 2 axis(max.)
Feed function / Acc. & Dec. control	
	Rapid traverse
Manual feed	Jog : 0~5,000mm/min (197 ipm) Manual handle : x1, x10, x100 pulses Reference position return
Cutting Feed command	Direct input F code
Feedrate override	0 ~ 200% (10% Unit)
Rapid traverse override	F0% (F1%), F25%, F50%, F100%
Override cancel	
Feed per minute	G94
Feed per revolution	G95
Look-ahead block	1,000 Block
Program input	
Tape Code	EIA / ISO
Optional block skip	9 ea
Absolute / Incremental program	G90 / G91
Program stop / end	M00, M01 / M02, M30
Maximum command unit	± 999,999.999 mm (± 99,999.9999 inch)
Plane selection	X-Y : G17 / Z-X : G18 / Y-Z : G19
Workpiece coordinate system	G52, G53, 48 pairs (G54.1 P1 ~ P48)
Manual absolute	Fixed ON
Programmable data input	G10
Sub program call	10 folds nested
Custom macro	#100~#199, #500~#599, #98000~#98499
Programmable mirror image	G51.1, G50.1

Controlled axis / Display / Accuracy Compensation	
Polar coordinate command	G15, G16
Do not look ahead function	G4.1
Including Chamfering / Corner R	
Canned cycle	G73, G74, G76, G80 ~ G89
Coordinate rotation	G68, G69
Scaling	G50, G51
Auxiliary function / Spindle speed function	
Auxiliary function	M 4 digit
Level-up M Code	Multi / By-Pass
Spindle speed command	S 5 digit , Binary output
Spindle override	50% ~ 120% (10% Unit)
Spindle orientation	M19
FSSB high speed rigid tapping	
Tool function / Tool compensation	
Tool function	Max. T 8 digit
Tool life management	256 pairs ☆
Tool offset pairs	400 pairs
Tool nose radius compensation	G40, G41, G42
Tool nose length compensation	G43, G44, G49
Tool offset memory C	Tool length, diameter, abrasion (Length/Dia.)
Tool length measurement	Z axis Input C
Editing function	
Part program storage size	10240m (4MB)
No. of registerable programs	1,000 ea
Program protect	
Background editing	
Extended part program editing	
Memory card program edit	Copy, move and change of file program
Protection of data at 8 levels	
Data input / output & Interface	
I/O interface	Memory card, USB memory interface Embedded Ethernet interface
Screen hard copy	
External message	
External key input	
External workpiece number search	
Automatic data backup	
Setting, display and diagnosis	
Self-diagnosis function	
History display	Alarm & Operator message & Operation
Run hour / Parts count display	
Maintenance information	
Actual cutting feedrate display	
Display of spindle speed / T code	
Graphic display	
Operating monitor screen	
Power consumption monitoring	Spindle & Servo
Multi language display	Support 25 languages
Display language switching	Selection of 5 optional Languages
LCD Screen Saver	Screen saver
Macro Excutor	Custom software 8MB (WIA Screen)☆
Processing select	Speed/ridigity setting

Option	
Fast ethernet	Needed option board
Data server	Needed option board (1GB, 2G, 4GB)
Sub Spindle control	☆
Polar coordinate interpolation	G12.1, G13.1
Cylindrical interpolation	G07.1
Manual handle feed	2/3 units
Tool offset number	Max. 2,000 pair
Program storage capacity	~ 8 MByte
Program registration number	Max. 4,000 ea
Additional work coordinate	300 pair (G54.1 P1 ~ P300)

Figures in inch are converted from metric values.
The FANUC controller specifications are subject to change based on the policy of company CNC supplying.

CONTROLLER

SIEMENS 840D sl

[] : Option ☆ Needed technical consultation

Controlled axis / Display / Accuracy Compensation	
Control axis	4 axis (X1, Y1, Z1, B1)
Simultaneously controlled axis	Max. 4 axis
Least setting Unit	X, Y, Z axis : 0.001 mm (0.0001 inch), B axis : 1 deg [0.001 deg]
Least input increment	X, Y, Z axis : 0.001 mm (0.0001 inch), B axis : 1 deg [0.001 deg]
Inch / Metric changeover	G70 (inch) / G71 (metric)
Interlock	All axis / Each axis
Machine lock	All axis
Backlash compensation	
Pitch error compensation	
Feedforward control (Torque control)	
LCD / MDI	12 inch color LCD
Keyboard	ABCD Type
Stored stroke check	Over travel
Operation	
Automatic operation (Memory)	
MDI operation	
Program restart	
Program check function	Dry run / Program check / Machine lock
Single block	
Block search	Block search
Reposition	
Working area limit	Working area limitations
Interpolation functions	
Positioning	G00
Linear interpolation	G01
Circular interpolation	Circular Interpolation CW (G02) Circular Interpolation CCW (G03)
Exact position stop	Single block exact stop (G09) Exact stop G60 (G601, G602, G603)
Dwell	Dwell (G04)
Reference position return	Return to reference point Return to 2nd reference point
Helical interpolation	
Spline interpolation	Non-uniform rational B splines
Feed function / Acc. & Dec. control	
	Rapid traverse
Manual feed	Jog Manual handle Reference position return
Cutting Feed command	Direct input F code
Feedrate override	0 ~ 120%
Rapid traverse override	1%, 25%, 50%, 100%
Feed per minute	G94
Feed per revolution	G95
Program input	
ISO correspondence	G291(ISO)/G290 (SIEMENS) (ISO G Code system-A)
Optional block skip	8# (0~7)
Program stop / end	G90 / G91
Absolute / Incremental program	M00, M01 / M02, M30
Maximum command unit	± 999,999,999 mm, ± 99,999,9999 inch
Plane selection	X-Y : G17, X-Z : G18, Y-Z : G19 G54 ~ G57, G505~G549
Workpiece coordinate system	G500 (Basic frame - settable zero offset) G53 (Work offset non modal) G153 (basic frame non modal)
Sub program call	16 folds nested
G code preventing buffering	STOPRE
Drilling/Milling cycle	with programing support
User cycle	

Auxiliary function / Spindle speed function	
Auxiliary function	M Code 4 digit
Spindle speed function	S Code 5 digit
Spindle override	0% ~ 120%
Spindle orientation	SPOS
Rigid tapping	
Automatic mode Interchange	Spindle / Axis mode
Constant surface speed control	G96, G97
Spindle speed limitation	LIMS
Tool function / Tool compensation	
Tool function	Tool number & Tool name
Tool life management	
Tools in tool list	600 ea
Cutting Edges in tool list	1,500 ea
Tool radius compensation	ISO (G40, G41, G42)
Geometry / Wear compensation	
Tool management function	
Editing function	
Part program storage size	10MB
External Storage devices	USB
Background editing	
Extended part program editing	Copy, move and change of NC program
Memory card program edit	
Data input / output & Interface	
I/O interface	USB memory interface Embedded Ethernet memory interface
Screenshot	
Setting, display and diagnosis	
Self-diagnosis function	
History display & Operation	Alarm & Operator message & Operation
Run hour / Parts count display	
Actual cutting feedrate display	
Display of spindle speed / T code	
Graphic display	
Operating monitor screen	Spindle / Servo load etc.
Multi language display	Support 7 languages Chinese, English, French, German, Italian, Korean, Spanish
LCD Screen Saver	Screen saver & Motion sensing

Option	
ShopMill	Machining step programming for milling
3D simulation	
Real time simulation	
Compressor (Improving machining quality)	Compcad / Compcurv (Cycle 832)
Look-ahead block	3,000 block (With Mdynamics)
Measurement of tool length	
Built-in PC	Industrial PC (IPC427E)
Multi language display	☆ 20 Support languages : Inquiry need

GLOBAL NETWORK

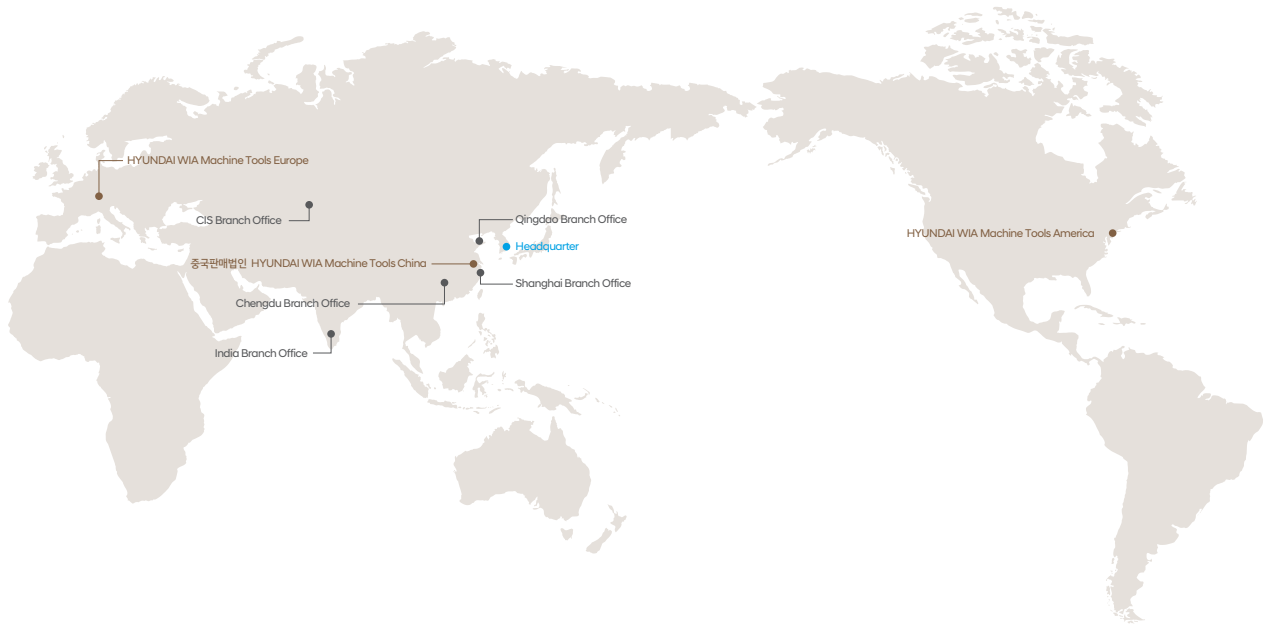

HEADQUARTER



R&D Center/Factory

153, Jeongdong-ro, Seongsan-gu,
Changwon-si, Gyeongsangnam-do, Korea
TEL : +82 55 280 9114



Overseas Sales Team /R&D Center

37, Cheoldobangmulgwan-ro, Uuiwang-si,
Gyeonggi-do, Korea
TEL : +82 31 8090 2539

EUROPE



HYUNDAI WIA Machine Tools Europe

Alexander-Fleming-Ring 57, DE-65428
Russelsheim am Main, Germany
TEL : +49-0-6142-9256-0

AMERICA



HYUNDAI WIA Machine Tools America

450 Commerce Blvd, Carlstadt, NJ 07072, USA
TEL : +1-201-987-7298

ASIA



HYUNDAI WIA Machine Tools China

Company No.16 Fenghuang Road, Fenghuang
Town, Zhangjiagang City, Jiangsu Province, China
TEL : +86-512-5637-9719



Shanghai Branch Office (China)

3F-04, MT1, MixC Park, No.229, Haowen Road,
Minhang District, Shanghai, China
TEL : +86-21-6427-9885



Chengdu Branch Office (China)

Room 409B, Building 1, No.333, Yizhou Road,
High-Tech District, Chengdu, China
TEL : +86-21-5952-3256



Qingdao Branch Office (China)

Room 702, Yulong International Center, Building
1, No. 178-2, Haier Road, Laoshan District,
Qingdao, China. C.P. 266035
TEL : +86-28-8666-2985



CIS Branch Office

050051, Kazakhstan, Almaty, Elebekova street 10,
B.3, Office no.103
TEL : +7-(727)-355-7133



India Branch Office

#4/169, 1st Floor, LOTTE BLDG, Rajiv Gandhi
Salai, (OMR), Kandanchavadi, Chennai -600 096,
Tamilnadu, India
TEL : +91-76049-01618



You Tube HYUNDAI WIA MT
www.youtube.com/HYUNDAIWIAMT

CREATING VALUE IN SEAMLESS MOBILITY

With its top-quality HYUNDAI WIA machine tool creates a new and better world.



<http://machine.hyundai-wia.com>
HYUNDAI WIA Machine Tools
Global Links