

# HS

# 10000

High-speed & Large Horizontal Machining Center

WIA Machine Tools Horizontal Machining Center

**WIA** MACHINE TOOLS

# Technical Leader

Horizontal Machining Center HS10000, designed by WIA machine tools with years of expertise and the latest technology, provides high speed, high performance and maximum productivity.

## HS10000

Pallet Size (L×W)	mm(in)	2-1,000×1,000 (39.4"×39.4")
Max. Load Capacity	kg(lb)	2-3,000 (6,614) [5,000 (11,023)]
Spindle Taper	-	BBT50
Spindle Speed	r/min	10,000 [14,000] [6,000]
Spindle Output (Max./Cont.)	kW(HP)	45/25 (60/33.5) [37/30 (50/40)] [55/30 (74/40)]
No. of Tools	EA	60 [90, 120, 150] [Matrix : 180, 240]
Travel (X/Y/Z)	mm(in)	1,700/1,400/1,550 (66.9"/55.1"/61")
Rapid Traverse Rate (X/Y/Z)	m/min(ipm)	50/50/50 (1,969/1,969/1,969) [5 ton Pallet : 50/50/40 (1,969/1,969/1,575)]

[ ] : Option

# HS 10000

Next Generation High Efficiency Large Machining Center

- High-performance 10,000rpm built-in spindle
- All-axis shaft cooling type ball screw
- Application of the largest tool in its class
- Rotary turn APC for high speed pallet change
- Best-in-class rapid traverse rate of 50 m/min (1.969 ipm)
- Adopted the latest controller of FANUC 31i B Plus



# 01 BASIC STRUCTURE

High Quality & Productivity Horizontal Machining Center

## ATC & Magazine

- No. of Tools : 60 [90/120/150] EA  
(MATRIX : 180/240 EA)
- Tool Selection Method : Fixed

## High Precision Spindle

- Built-in Spindle : 10,000 [14,000] [6,000] r/min
- Oil Cooling System
- BBT50

## APC & Pallet

- Rotary Turn Type (25 sec)
- Pallet Size (X/Y) :  
1,000×1,000 mm (39.4"×39.4")
- Max.Load Capacity :  
3,000 [5,000] kg (6,614 [11,023] lb)

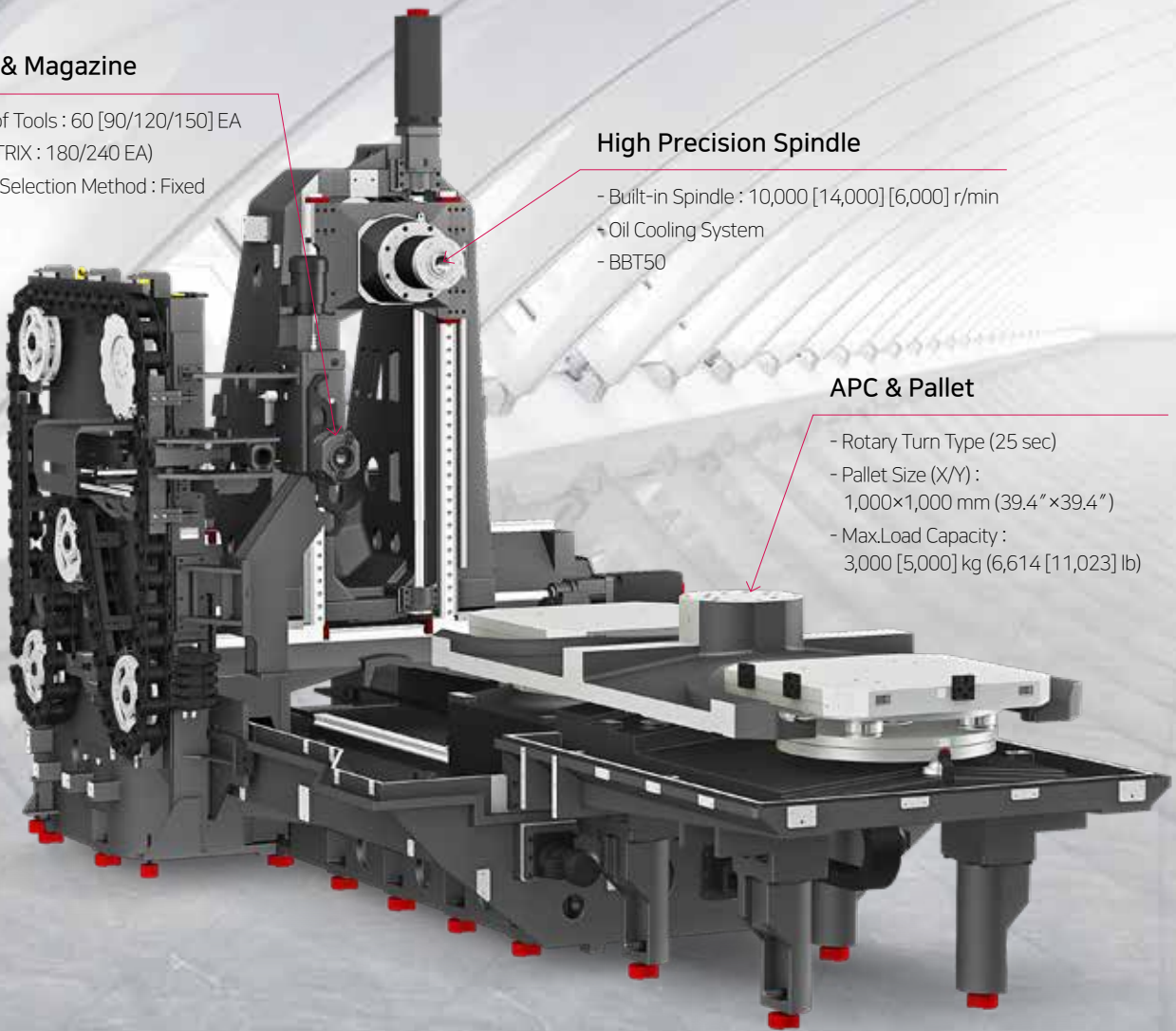

# HIGH RIGIDITY, OPTIMAL MACHINING PERFORMANCE

## HIGH RIGIDITY STRUCTURE

### Step Type Bed Structure

It is designed to minimize the thrust force occurring at Z-axis machining. Also, travel stability is increased by column weight optimization.

**Floor Space** (L×W) **5,520×8,303** mm (60 tool)  
(217.3"×326.9")



## GUIDEWAY

### High-speed Roller Type LM Guideway

Roller bearing type LM guideways are applied to reduce non-cutting time and bring high rigidity.

Each axis is directly connected to a highly reliable digital servo motor to provide high rigidity and minimal thermal displacement.



### Enlarged Guideway Width

HS10000 shown 10mm increased guideway width compared to similar size machine to improve heavy duty cutting performance.



### All Axis Ball Screw Shaft Cooling

Shaft cooling type ball screw as a standard in order to minimize thermal displacement from repetitive motion of ball screw.

**Travel (X/Y/Z)**

**1,700/1,400/1,550** mm

(66.9"/55.1"/61")

**Rapid Traverse Rate (X/Y/Z)**

**50/50/50** m/min [5 ton Pallet : 50/50/40 m/min]

(1,969/1,969/1,969 ipm [5 ton Pallet : 1,969/1,969/1,575 ipm])

HS10000

# 02 HIGH PRECISION SPINDLE

Excellent machining performance with high-precision spindle

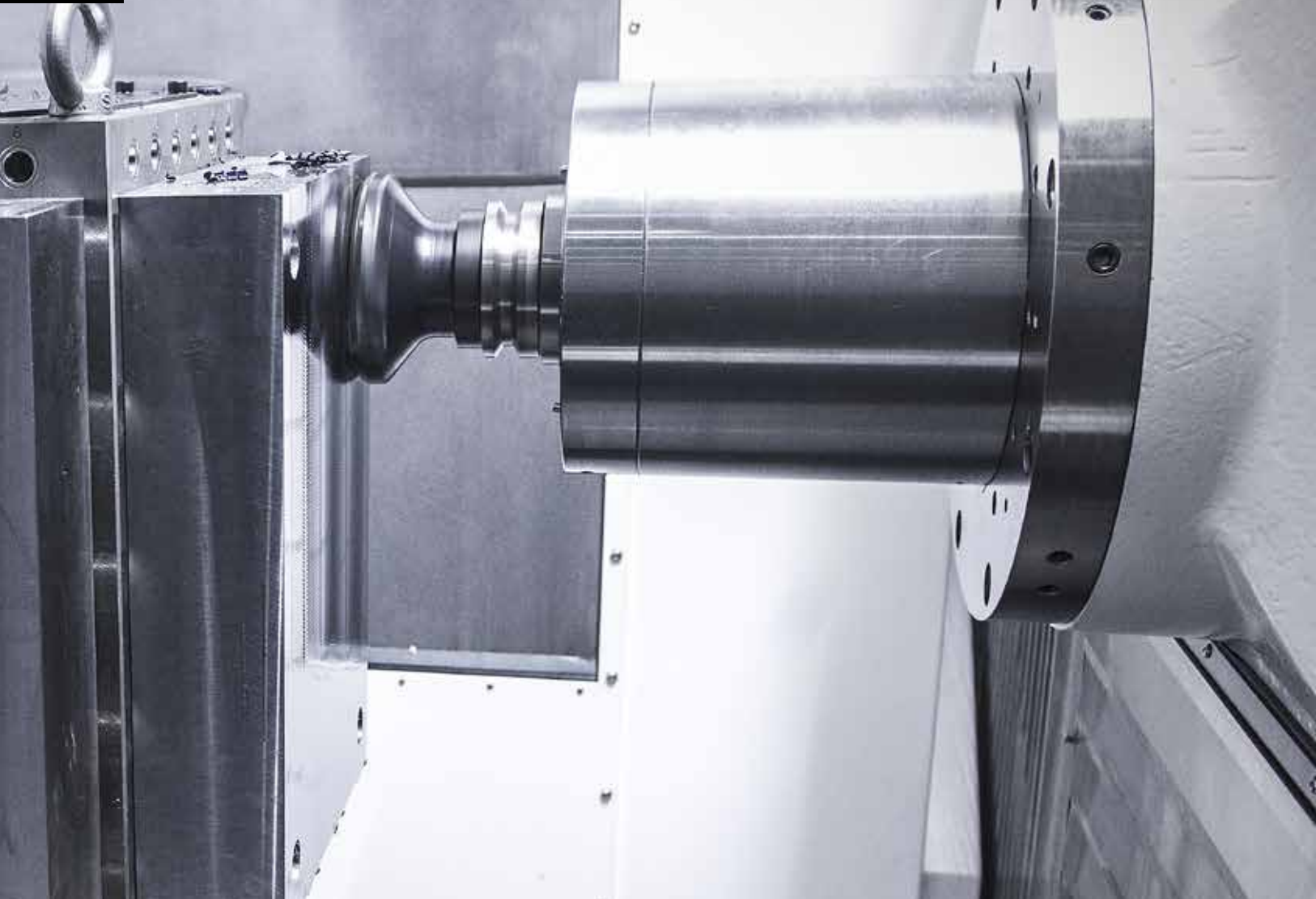

**The secret to maintaining high quality even during a long-term machining, starts with the performance of the spindle.**

HS10000 incorporated a high performance built-in spindle as a standard.

The built-in spindle, with the spindle and motor combined, exhibits superior performance during high speed rotations, minimizing vibration.

In addition, HS10000 will realize the best-in-class acceleration and deceleration time of the spindle, contributing to improved productivity. By improving the acceleration performance of the spindle motor compared to competition models, it has shortened the time to reach the RPM necessary for machining, and the tool exchange time has been greatly improved by minimizing the spindle motor down time

# HIGH-SPEED, HIGH-POWER BUILT-IN SPINDLE

## SPINDLE

### Built-in Spindle

By using ultra precision class angular ball bearings, fast acc/deceleration of the main spindle is achieved. The spindle head is designed to minimize heat displacement therefore reducing heat generation and making it possible to maintain high accuracy.

### Oil Cooling System.

Spindle temperature is controlled by the use of a spindle oil chiller. This ensures consistent spindle temperature which minimizes thermal displacement.

### Through Spindle Coolant (20/30/70 bar) **OPTION**

Through Spindle Coolant is exceedingly useful when drilling deep holes. It helps increase the lifetime of the tool, while decreasing cycle time.

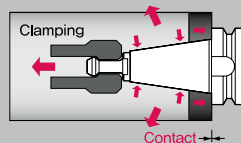

### Dual contact Spindle

The Big Plus spindle system (BBT#50) provides dual contact between the spindle face and the flange face of the tool holder.

### Spindle Specifications

[ ]: Option

Speed (rpm)	Motor (Max./Cont.)	Torque (Max./Cont.)	Type
10,000 rpm	45/25 kW (60/33.5 HP)	623/305 N.m (459.5/225 lbf.ft)	Built-in
[14,000 rpm]	[37/30 kW (50/40 HP)]	[398/191 N.m (293.6/140.9 lbf.ft)]	
[6,000 rpm]	[55/30 kW (74/40 HP)]	[807/353 N.m (595.2/260.4 lbf.ft)]	

### 8-ch Thermal Displacement Compensation Device **OPTION**

The HS10000 detects thermal displacement by eight detecting sensors installed in the main heat source and automatically corrects the displacement to ensure excellent precision machining..

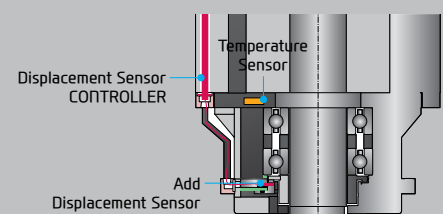

# 03 APC & ATC

Reduction of non cutting time by high-speed ATC & APC

## APC & Pallet Specifications

[ ] : Option

Pallet Size	Max. Load Capacity	Min. Indexing Angle	APC Type
2-1,000×1,000 mm (39.4"×39.4")	2-3,000 [5,000] kg (6,613 [11,023] lb)	1° [0.001°]	Rotary Turn

## ATC & Magazine Specifications

No. of Tools	Max. Tool Dia. (W.T/W.O)	Max. Tool Length	Max. Tool Weight
60 [90, 120, 150] EA	Ø135/Ø320 mm (Ø5.3"/Ø12.6")	800 mm (31.5")	30 kg (66.1 lb)

# INCREASED PRODUCTIVITY THROUGH HIGH SPEED ATC & APC

## APC & PALLET

### High Speed APC

HS10000 provides a lift rotary type APC(automatic pallet changer) as standard. The loading station pallet can be rotated and locked in 90° increments for convenient loading/unloading of workpieces.

### 5T Pallets for Heavy Materials **OPTION**

The HS10000 offers max load weight 5T pallet for heavy materials machining as an option.

APC Change Time **25** SEC (Vacant)

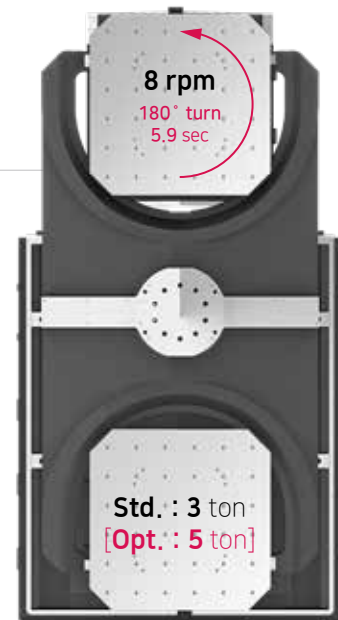

## ATC & MAGAZINE

### High Speed Servo Motor Driven ATC

The tool magazine holds 60 tools as standard and up to 150 tools as an option.

Servo control, fixed address tool selection method and a separate magazine control panel enhance user convenience. The twin arm ATC provides fast and reliable tool change to reduce non-cutting time.

Chip to Chip **4.1** sec

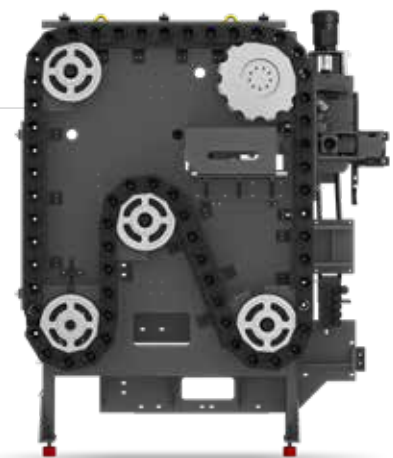

Max. Tool Dia. / Length

**Ø320/800** mm

Max. Tool Weight

**30** kg (60 ~ 150 Tool)

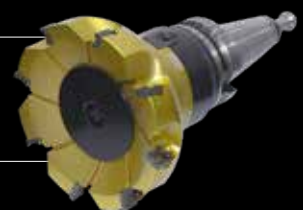

# 04 FANUC - SMART PLUS

The Compatible All-round Control

## FANUC 31i-B Plus

This is the core model of FANUC CNC with the performance of the world highest level. With abundant functions and high-speed, highly-accurate and high-quality machining technology, it is the most suitable for a high-grade and machining center.



### 15" Touch Screen Monitor Applied

Control axis : 4 axis (X, Y, Z, B)

Simultaneously controlled axis :  
3 axis [Max. 4 axis]

Part program storage size : 4 Mbyte (10240m)

No. of registerable programs : 1,000 EA

Tool offset pairs : 400 pairs

Look-ahead block : 1,000 block

Conversational auto program : Smart Guide i

The HS10000 has a 15" large monitor for enhanced visibility.

In particular, we can create more convenient use conditions by improving the operating environment such as program setup and simulation through a large screen.



Convenience is increased when inputting and outputting program. The USB port is available in addition to the former input output methods such as CF memort card and LAN.

## 8Ch. Thermal displacement compensation **OPTION**

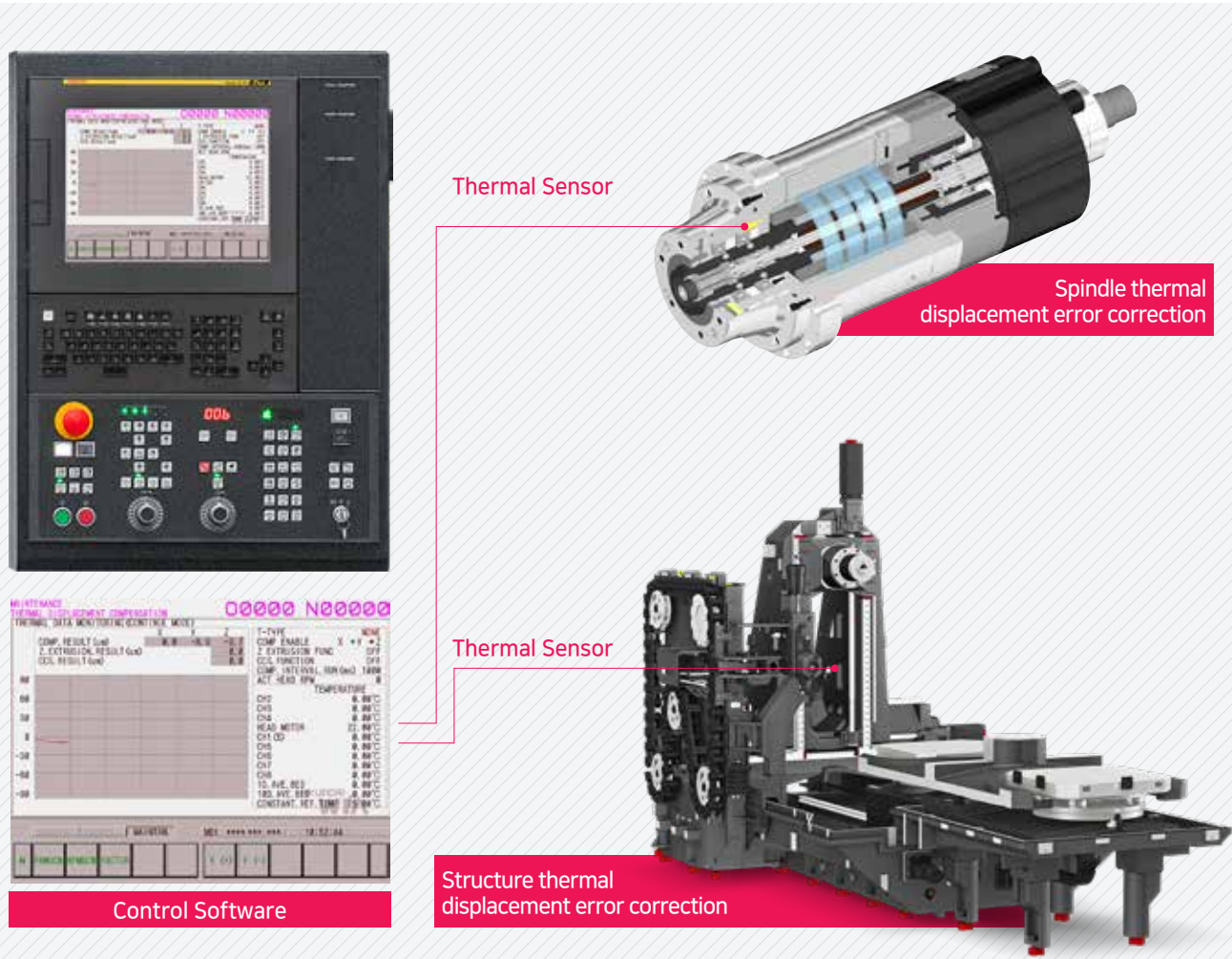

Machine tools generate thermal displacement due to heat during machining. WIA machine tools detect thermal changes through thermal sensors installed on the main thermal sources of the machine. In addition, a thermal displacement compensation device that predicts the amount of thermal displacement according to the amount of thermal change and provides a command to the motor with a compensated value to maintain consistent precision is provided as an option.

## SMART CNC (FANUC Smart Plus)

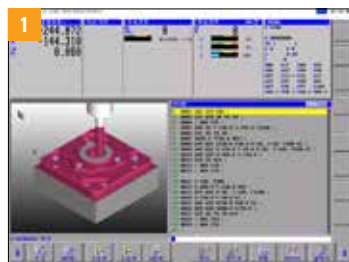

### 1. Dialogue Program (Smart Guide-i)

This software offers the maximum user convenience through dialogue manipulation from setup to processing. This includes writing processing programs and simulation checks.

### 2. LAUNCHER

This software offers shortcuts for quick access to specialized features and frequently used features.

# SPECIFICATIONS

## Standard & Optional

● : Standard ○ : Option ☆ : Prior Consultation - : Non Applicable

Spindle		HS10000
10,000rpm (45/25kW)	Built-In	●
14,000rpm (37/30kW)	Built-In	○
6,000rpm (55/30kW)	Built-In	○
Spindle Cooling System		●
<b>ATC</b>		
ATC Extension	60	●
	90	○
	120	○
	150	○
	180 (MatrixX)	○
	240 (MatrixX)	○
Tool Shank Type	BBT50	●
	HSK-A100	-
	BCV50	○
Tool Weight	30kg	●
U-Center	D'andrea	☆
Pull Stud	45°	●
Servo Motor Magazine		●
<b>Table, APC &amp; Pallet</b>		
APC	Rotary Turn	●
Pallet Max. Load Capacity	3 ton	●
	5 ton	○
Tap Type Pallet		●
T-Slot Pallet		○
B Axis Table	1°	●
	0.001°	○
<b>Coolant System</b>		
Std. Coolant (Nozzle)		●
Bed Flushing Coolant		●
*1) Through Spindle Coolant	20bar	○
	30bar, 20 ℓ (5.3 gel)	○
	70bar, 15 ℓ (4 gel)	○
	70bar, 20 ℓ (5.3 gel)	○
	70bar, 30 ℓ (7.9 gel)	○
Shower Coolant		○
Gun Coolant		○
Side Oil Hole Coolant		☆
Air Gun		○
Cutting Air Blow		○
Tool Measuring Air Blow (Only for TLM)		○
Air Blow for Automation		☆
Thru MQL Device (Without MQL)		☆
Coolant chiller (Sub Tank)		☆
Power Coolant System (For Automation)		☆
<b>Chip Disposal</b>		
Coolant Tank	900 ℓ (237.8 gal)	●
Chip Conveyor (Hinge/Scraper)	Rear-Right	○
Chip Conveyor (Magnetic)	Rear-Right	○
Chip Conveyor (Mesh Drum)	Rear-Right	○
Special Chip Conveyor (Drum Filter)		☆
Chip Wagon	Standard (180 ℓ [47.5 gal])	○
	Swing (200 ℓ [52.8 gal])	○
	Large Swing (290 ℓ [76.6 gal])	○
	Large Size (330 ℓ [87.2 gal])	○
	Customized	☆
<b>S/W</b>		
Dialogue Program (W-DPRO)		○
DNC software (W-eDNC)		○
Smart Guide-i : FANUC		●
Smart S/W		☆

Safety Device		HS10000
Total Splash Guard		●
<b>Electric Device</b>		
Call Light	1 Color : ●	●
Call Light & Buzzer	3 Color : ●●●	○
Work Light		●
Electric Cabinet Light		○
Remote MPG		●
3 Axis MPG		○
Work Counter	Digital	○
Total Counter	Digital	○
Tool Counter	Digital	○
Multi Tool Counter	6 EA	☆
	9 EA	☆
Electric Circuit Breaker		○
AVR (Auto Voltage Regulator)		☆
Transformer	65kVA	○
Auto Power Off		○
Back up Module for Black out		○
<b>Measuring Device</b>		
Air Zero	TACO	○
	SMC	○
Work Measuring Device		○
TLM (Marposs/Renishaw/Blum)	Touch	○
	Laser	○
Tool Broken Detective Device		☆
Linear Scale	X/Y/Z Axis	○
Pallet Close Confirmation Device		○
Coolant Level Sensor (Only for Chip Conveyor, Bladder Type)		☆
<b>Environment</b>		
Air Conditioner		○
Dehumidifier		○
Oil Mist Collector		☆
Oil Skimmer (Only for Chip Conveyor)		○
MQL (Minimal Quantity Lubrication)		☆
<b>Fixture &amp; Automation</b>		
Auto Door	Std.	○
	High Speed	☆
Auto Shutter (Only for Automatic System)		-
Sub O/P		☆
Control of Additional Axis	1Axis	☆
	2Axis	☆
External M Code 4EA		○
Automation Interface		☆
I/O Extension (In & Out)	16Contact	☆
	32Contact	☆
6PPL		○
PLS		○
<b>Hyd. Device</b>		
Std. Hyd. Unit	70bar/45 ℓ (11.8 gal)	●
Center Type Hyd. Supply Unit (Upper)	2×2 (4P)	☆
	2×4 (8P)	☆
	2×8 (16P)	☆
Hyd. Unit for Fixture	45bar	☆
	70bar	☆
	100bar	☆
	Customized	☆
<b>ETC</b>		
Tool Box		●
Customized Color	Need for Munsel No.	☆
CAD&CAM Software		☆
Thermal displacement compensation		○

\*1) Through Spindle Coolant : Please check the filter types with sales representative.  
Specifications are subject to change without notice for improvement.

# SPECIFICATIONS

## Spindle Output/Torque Diagram

### Built-in 10,000rpm

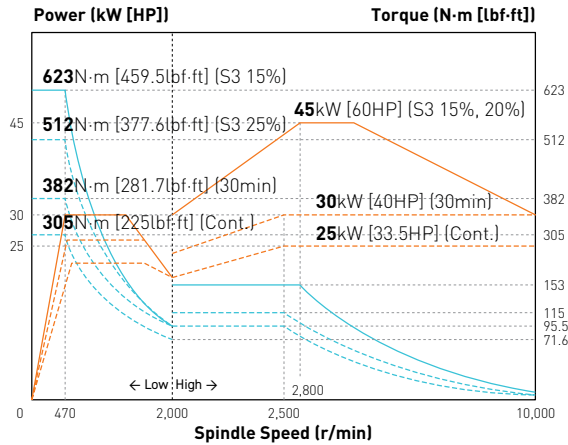

### Built-in 14,000rpm

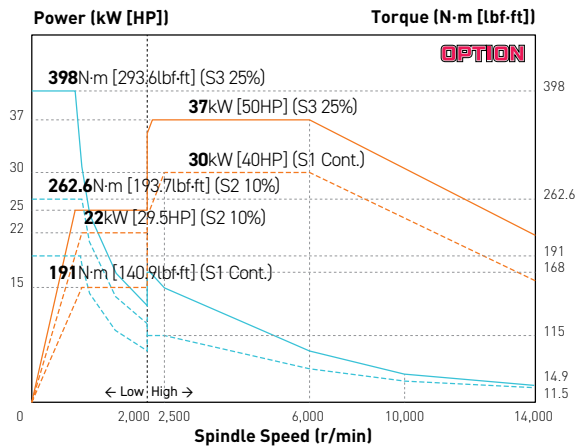

### Built-in 6,000rpm

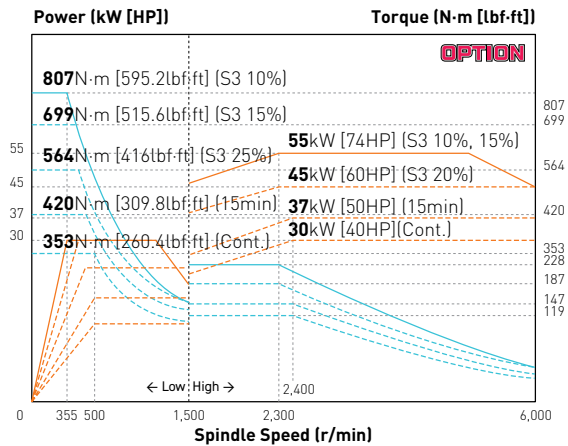

# SPECIFICATIONS

## External Dimensions

unit : mm(in)

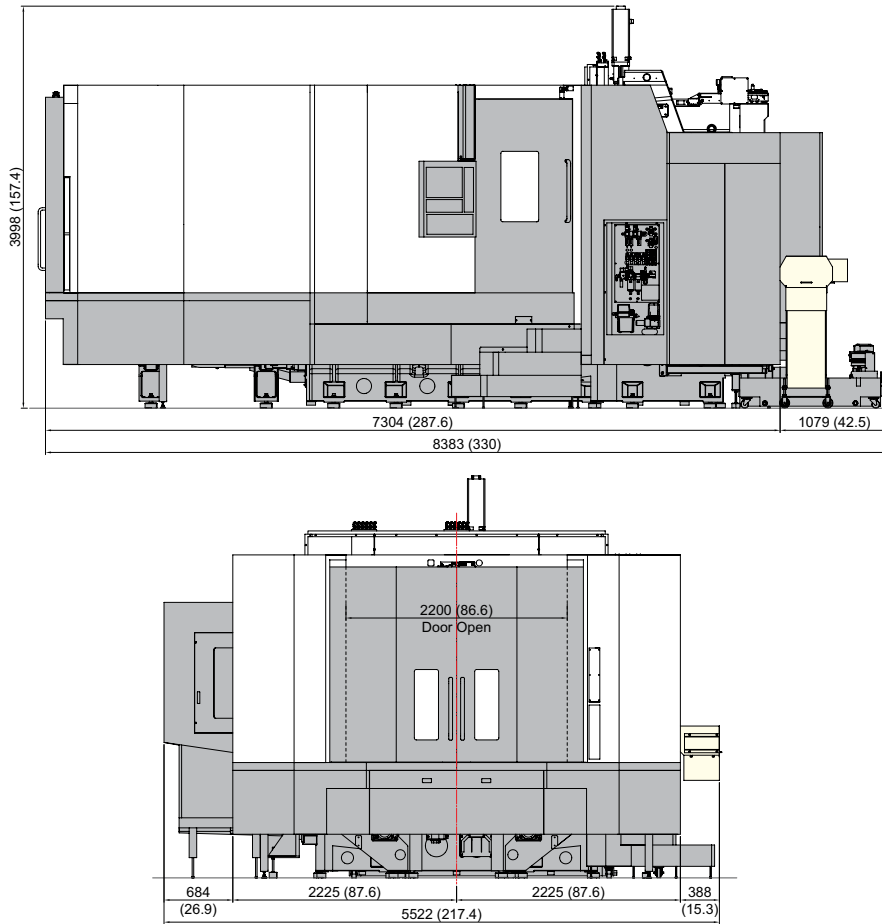

## Tool Shank

unit : mm(in)

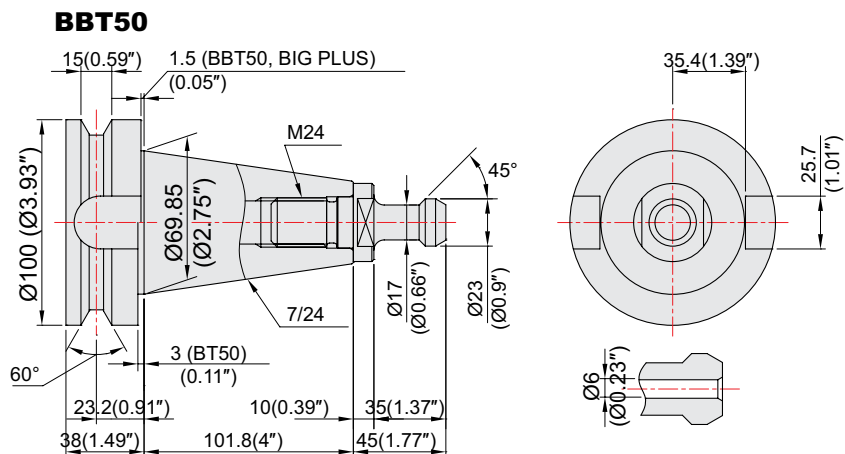

# SPECIFICATIONS

## Transfer Range & Machining Area

unit : mm(in)

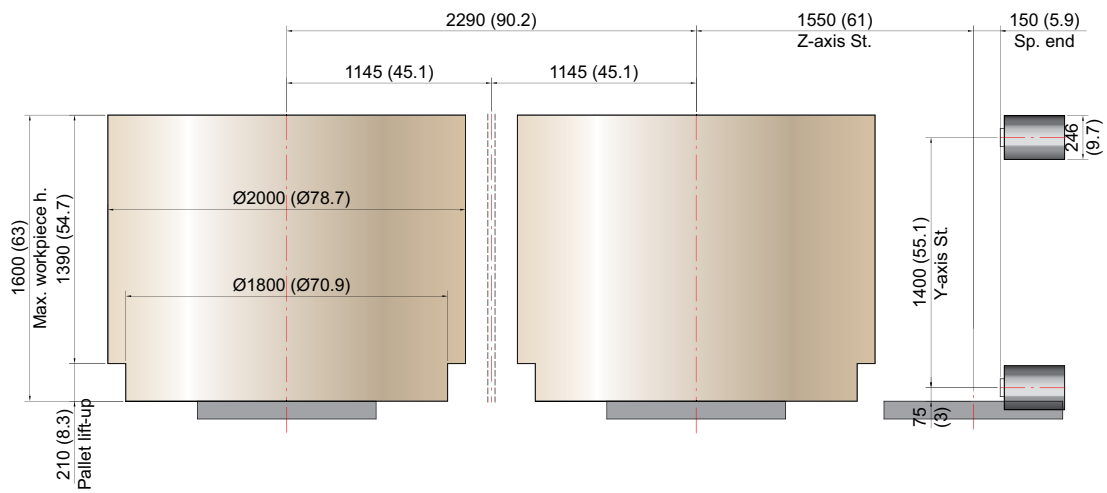
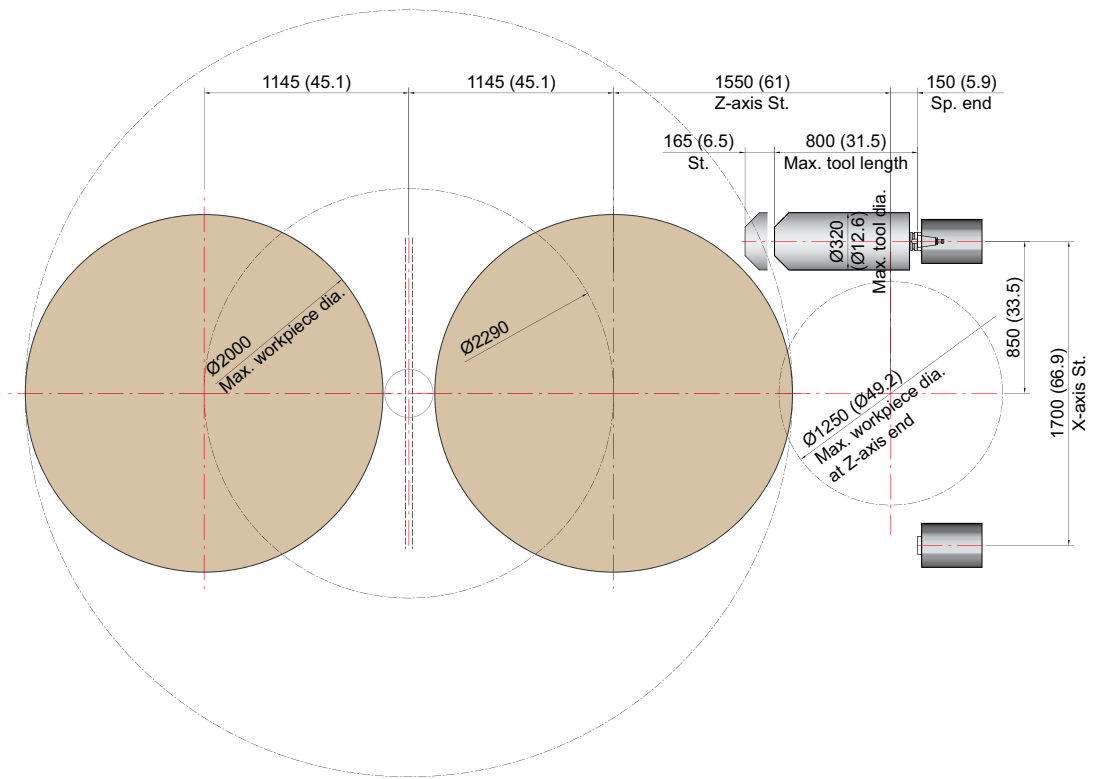

# SPECIFICATIONS

## Table Dimensions

unit : mm(in)

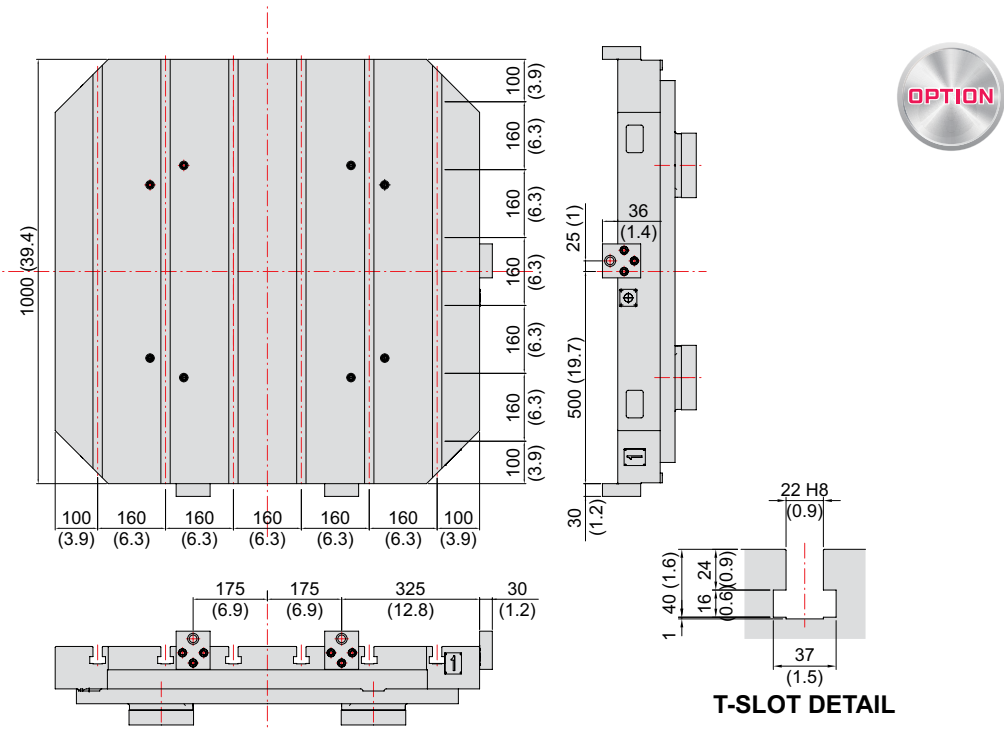
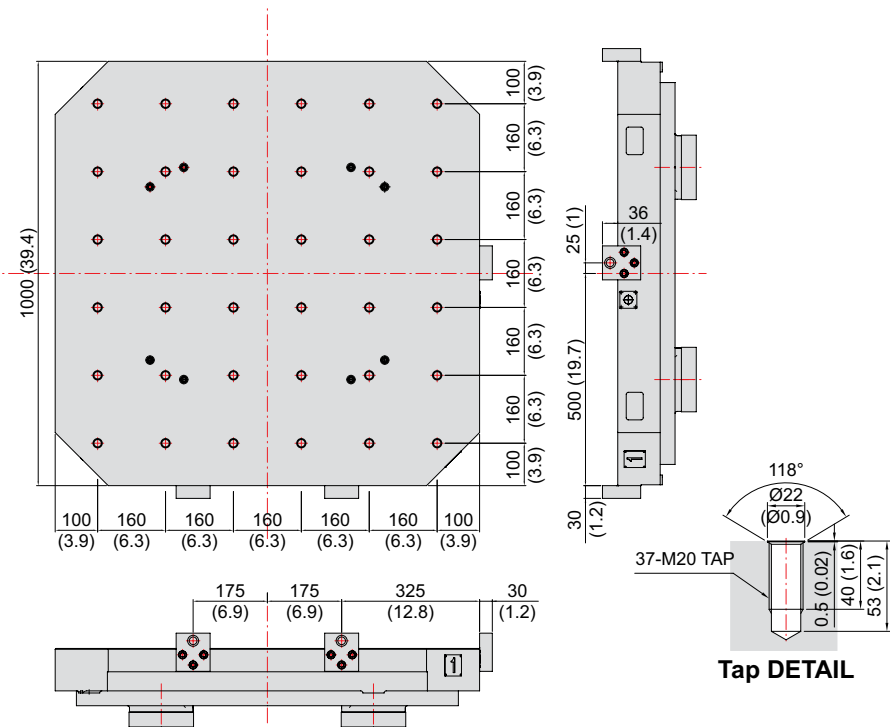

# SPECIFICATIONS

## Specifications

[ ] : Option

ITEM		HS10000	
PALLET	Pallet Size (L×W)	mm(in)	2-1,000×1,000 (39.4"×39.4")
	Maximum Load Capacity	kg(lbf)	2-3,000 (6,614) [5,000 (11,023)]
	Maximum Workpiece Size	mm(in)	Ø2,000×H1,600 (Ø78.7"×H63")
	Min. Indexing Angle	deg	1° [0.001°]
SPINDLE	Spindle Taper	-	BBT50
	Spindle RPM	r/min	10,000 [14,000] [6,000]
	Spindle Motor Output (Max./Cont.)	kW(HP)	45/25 (60/33.5) [37/30 (50/40)] [55/30 (74/40)]
	Spindle Torque (Max./Cont.)	N·m(lbf·ft)	623/305 (459.5/225) [398/191 (293.6/140.9)] [807/353 (595.2/260.4)]
	Spindle Driving Method	-	BUILT-IN
FEED	Travel (X/Y/Z axis)	mm(in)	1,700/1,400/1,550 (66.9"/55.1"/61")
	Distance from Table Top to Sp. Center	mm(in)	75~1,475 (3"/58.1")
	Distance from Table Center to Sp. Nose	mm(in)	150~1,550 (5.9"/61")
	Rapid Traverse Rate (X/Y/Z)	m/min(ipm)	50/50/50 (1,969/1,969/1,969) [5 ton Pallet : 50/50/40 (1,969/1,969/1,575)]
	Slide Type	-	ROLLER GUIDE
ATC	Number of Tools	EA	60 [90, 120, 150] [Matrix : 180, 240]
	Tool Shank	-	BBT50
	Max. Tool Dia. (W.T/W.O)	mm(in)	Ø135/Ø320 (Ø5.3"/Ø12.6")
	Max. Tool Length	mm(in)	800 (31.5")
	Max. Tool Weight	kg(lb)	30 (66.1)
	Tool Selection Method	-	FIXED ADDRESS
	Tool Change Time	T-T	sec
C-C		sec	4.1
APC	No. of Pallet	ea	2
	Pallet Change Time (Vacant)	sec	*25
	APC Type	-	ROTARY TURN
TANK CAPACITY	Coolant Tank	ℓ (gal)	900 (237.8)
	Lubricating Tank	ℓ (gal)	0.7 (0.2)
	Hyd. Tank Unit	ℓ (gal)	45 (11.9)
POWER SUPPLY	Air Consumption (0.5MPa)	ℓ /min(gal/min)	450 (118.9)
	Electric Power Supply	KVA	60
	Thickness of Power Cable	mm <sup>2</sup>	Over 50
	Voltage	V/Hz	220/60 (200/50*)
MACHINE	Floor Space (L×W)	mm(in)	5,520×8,303 (217.3"×326.9") (60 Tool)
	Height	mm(in)	3,998 (157.4")
	Weight	kg(lb)	34,000 (74,957)
CNC	Controller	-	FANUC 31i-B [FANUC i Series - Smart Plus]

\* APC changing time can vary depending on the weight of work piece.

\*) Using 50Hz voltage instead of 60Hz may lower the output of motors, (excluding servo motors and inverter motors)

Specifications are subject to change without notice for improvement.

# CONTROLLER

## FANUC 31i-B Plus

[ ]: Option ☆ Needed technical consultation

Controlled axis / Display / Accuracy Compensation	
Control axis	4 axis (X, Y, Z, B)
Simultaneously controlled axis	3 axis [Max. 4 axis]
Least setting Unit	X, Y, Z axis : 0.001 mm (0.0001 inch) B axis : 1 deg [0.001] deg
Least input increment	X, Y, Z axis : 0.001 mm (0.0001 inch) B axis : 1 deg [0.001] deg
Inch / Metric conversion	G20 / G21
High response vector control	
Interlock	All axis / Each axis
Machine lock	All axis
Backlash compensation	± 0 ~ 9999 pulses (Rapid traverse / Cutting feed)
Position switch	
LCD / MDI	15" color LCD with Touch screen
Feedback	Absolute motor feedback
Stored stroke check 1	Over travel
Stored stroke check 2, 3	
Pitch error compensation	
Operation	
Automatic operation (Memory)	
MDI operation	
DNC operation	Needed DNC software / CF card
Program restart	
Wrong operation prevention	
Program check function	Dry run, Program check Z axis Machine lock, Stroke check before move
Single block	
Search function	Program Number / Sequence Number
Retraction for rigid tapping	
Manual guide i	Smart Guide i
Interpolation functions	
Nano interpolation	
Positioning	G00
Linear interpolation	G01
Cylindrical interpolation	G02, G03
Exact stop mode	Single : G09, Continuous : G61
One-way positioning	G60
Inverse-time feed	G93
Dwell	G04, 0 ~ 9999.9999 sec
Skip	G31
Reference position return	1st reference : G28 2, 3, 4 reference : G30 P2, P3, P4 Ref. position check : Z7
Thread synchronous cutting	G33
Helical interpolation	Circular + Linear interpolation 2 axis(max.)
Feed function / Acc. & Dec. control	
Manual feed	Rapid traverse Jog : 0~5,000mm/min (197 ipm) Manual handle : x1, x10, x100 pulses Reference position return
Cutting Feed command	Direct input F code
Feedrate override	0 ~ 200% (10% Unit)
Rapid traverse override	F0% (F1%), F25%, F50%, F100%
Override cancel	
Feed per minute	G94
Feed per revolution	G95
Look-ahead block	1,000 Block
Program input	
Tape Code	EIA / ISO
Optional block skip	9 ea
Absolute / Incremental program	G90 / G91
Program stop / end	M00, M01 / M02, M30
Maximum command unit	± 999,999.999 mm (± 99,999.9999 inch)
Plane selection	X-Y : G17 / Z-X : G18 / Y-Z : G19
Workpiece coordinate system	G52, G53, 48 pairs (G54.1 P1 ~ P48)
Manual absolute	Fixed ON
Programmable data input	G10
Sub program call	10 folds nested
Custom macro	#100~#199, #500~#599, #98000~#98499
Programmable mirror image	G51.1, G50.1

Controlled axis / Display / Accuracy Compensation	
Polar coordinate command	G15, G16
Do not look ahead function	G4.1
Including Chamfering / Corner R	
Canned cycle	G73, G74, G76, G80 ~ G89
Coordinate rotation	G68, G69
Scaling	G50, G51
Auxiliary function / Spindle speed function	
Auxiliary function	M 4 digit
Level-up M Code	Multi / By-Pass
Spindle speed command	S 5 digit, Binary output
Spindle override	50% ~ 120% (10% Unit)
Spindle orientation	M19
FSSB high speed rigid tapping	
Tool function / Tool compensation	
Tool function	Max. T 8 digit
Tool life management	256 pairs ☆
Tool offset pairs	400 pairs
Tool nose radius compensation	G40, G41, G42
Tool nose length compensation	G43, G44, G49
Tool offset memory C	Tool length, diameter, abrasion (Length/Dia.)
Tool length measurement	Z axis Input C
Editing function	
Part program storage size	10240m (4MB)
No. of registerable programs	1,000 ea
Program protect	
Background editing	
Extended part program editing	
Memory card program edit	Copy, move and change of NC program
Protection of data at 8 levels	
Data input / output & Interface	
I/O interface	Memory card, USB memory interface Embedded Ethernet interface
Screen hard copy	
External message	
External key input	
External workpiece number search	
Automatic data backup	
Setting, display and diagnosis	
Self-diagnosis function	
History display	Alarm & Operator message & Operation
Run hour / Parts count display	
Maintenance information	
Actual cutting feedrate display	
Display of spindle speed / T code	
Graphic display	
Operating monitor screen	
Power consumption monitoring	Spindle & Servo
Multi language display	Support 25 languages
Display language switching	Selection of 5 optional Languages
LCD Screen Saver	Screen saver
Macro Excutor	Custom software 8MB (WIA Screen) ☆
Processing select	Speed/ridgity setting
Option	
Fast ethernet	Needed option board
Data server	Needed option board (1GB, 2G, 4GB)
Sub Spindle control	☆
Polar coordinate interpolation	G12.1, G13.1
Cylindrical interpolation	G07.1
Manual handle feed	2/3 units
Tool offset number	Max. 2,000 pair
Program storage capacity	~ 8 MByte
Program registration number	Max. 4,000 ea
Additional work coordinate	300 pair (G54.1 P1 ~ P300)

Figures in inch are converted from metric values.

The FANUC controller specifications are subject to change based on the policy of company CNC supplying.

# CONTROLLER

## FANUC i Series - Smart Plus

[ ] : Option ☆ Needed technical consultation

Controlled axis / Display / Accuracy Compensation	
Control axis	3 axis (X, Y, Z) [4 axis (X, Y, Z, A)] [5 axis (X, Y, Z, A, C)]
Simultaneously controlled axis	3 axis [Max. 4 axis]
Least setting Unit	X, Y, Z axis : 0.001 mm (0.0001 inch) B axis : 1 deg [0.001] deg
Least input increment	X, Y, Z axis : 0.001 mm (0.0001 inch) B axis : 1 deg [0.001] deg
Inch / Metric conversion	
High response vector control	
Interlock	All axis / Each axis
Machine lock	All axis
Backlash compensation	± 0 ~ 9999 pulses (Rapid traverse / Cutting feed)
Position switch	
LCD / MDI	15 inch LCD unit (with Touch Panel)
Feedback	Absolute motor feedback
Stored stroke check 1	Over travel
Stored stroke check 2, 3	
Stored pitch error compensation	
Operation	
Automatic operation (Memory)	
MDI operation	
DNC operation	Needed DNC software / CF card
Program restart	
Wrong operation prevention	
Program check function	Dry run, Program check, Z axis Machine lock Stored limit check before move
Single block	
Search function	Program Number / Sequence Number
Handle interruption	
Interpolation functions	
Nano interpolation	
Positioning	G00
Linear interpolation	G01
Circular interpolation	G02, G03
Exact stop mode	Single : G09, Continuous : G61
Dwell	G04, 0 ~ 9999.9999 sec
Skip	G31
Reference position return	1st reference, G28 / 2nd reference, G30 Ref. position check, G27
Single direction positioning	G60
Thread synchronous cutting	G33
Helical interpolation	Circular + Linear 2 axis (Max.)
Feed function / Acc. & Dec. control	
Manual feed	Rapid traverse Jog : 0~2,000mm/min (79 ipm) Manual handle : x1, x10, x100 pulses Reference position return
Cutting Feed command	Direct input F code
Feedrate override	0 ~ 200% (10% Unit)
Rapid traverse override	1%, 25%, 50%, 100%
Override cancel	
Feed per minute	G94
Feed per revolution	G95
Cylindrical interpolation	G07.1
Inverse time feed	G93
Look-ahead block	200 blocks (AI APC)
Program input	
Tape Code	EIA / ISO
Optional block skip	9 ea
Absolute / Incremental program	G90 / G91
Program stop / end	M00, M01 / M02, M30
Maximum command unit	± 999,999.999 mm (± 99,999.9999 inch)
Plane selection	X-Y, G17 / Z-X, G18 / Y-Z, G19
Workpiece coordinate system	G52, G53, 48 pairs (G54.1 P1 ~ 48)
Manual absolute	Fixed ON
Programmable data input	G10
Sub program call	10 folds nested
Custom macro	#100 ~ #199, #500 ~ #999
Programmable mirror image	G51.1, G50.1
G code preventing buffering	G4.1
Optional chamfering corner R	

Program input	
Polar coordinate command	G15, G16
Canned cycle	G73, G74, G76, G80 ~ G89
Scaling	G50, G51
Coordinate system rotation	G68, G69
Conversational Program	Smart Guide-i
Auxiliary function / Spindle speed function	
Level-up M Code	Multi / Bypass M code
Spindle speed function	S & 5 digit, Binary output
Spindle override	0% ~ 150% (10% Unit)
Spindle orientation	M19
Retraction for rigid tapping	
FSSB high speed rigid tapping	
Tool function / Tool compensation	
Tool function	Max. T8 digit
Tool life management	
Tool offset pairs	400 pairs
Tool nose / radius compensation	G40, G41, G42
Tool length offset	G43, G44, G49
Tool offset memory C	Tool geometry and wear (Cutter and tool length)
Tool length measurement	Z axis Input C
Editing function	
Part program storage size	5,120m (2MB)
No. of registerable programs	1,000 ea
Program protect	
Background editing	
Extended part program editing	Copy, move and change of NC program
Memory card program edit	
Data input / output & Interface	
I/O interface	CF card, USB memory Embedded Ethernet interface
Screen hard copy	
External message	
External key input	
External workpiece number search	
Automatic data backup	
Setting, display and diagnosis	
Self-diagnosis function	
History display & Operation	Alarm & Operator message & Operation
Run hour / Parts count display	
Maintenance information	
Actual cutting feedrate display	
Display of spindle speed / T code	
Graphic display	
Operating monitor screen	Spindle / Servo load etc.
Power consumption monitoring	Spindle & Servo
Spindle / Servo setting screen	
Multi language display	Support 24 languages
Display language switching	Selection of 5 optional Languages
LCD Screen Saver	Screen saver
Option	
Fast ethernet	Needed option board
Data server	Needed option board
Protection of data at 8 levels	
Additional Axis	
Manual handle feed	2/3 units #100 ~ #199, #500 ~ #999, #98000 ~ #98499
Addition of custom macro	#100 ~ #199, #500 ~ #999, #98000 ~ #98499
Add. Workpiece	Max. 300 pairs (G54.1 P1 ~ P300)
AICC II	400 blocks ☆

Figures in inch are converted from metric values.

The FANUC controller specifications are subject to change based on the policy of company CNC supplying.

# WIA MACHINE TOOLS



home page



facebook



youtube



instagram



linkedin

---

**Headquarter / R&D Center** 106, Yongji-ro, Seongsan-gu, Changwon-si, Gyeongsangnam-do, Republic of Korea TEL : +82 55 225 9999

---

**Overseas Sales Team** 13, Iljik-ro 12beon-gil, Gwangmyeong-si, Gyeonggi-do, Republic of Korea TEL : +82 055 225 9645

---

## OVERSEAS OFFICES

---

**America corp.** 450 Commerce Blvd, Carlstadt, NJ 07072, USA TEL : +1-201-987-7298

---

**Europe GmbH** Alexander-Fleming-Ring 57, 65428 Russelsheim Germany TEL : +49-0-6142-9256-0

---

**China** Company No.16 Fenghuang Road, Fenghuang Town, Zhangjiagang City, Jiangsu Province, China TEL : +86-21-6427-9885

---

**CIS Branch Office** 050051, Kazakhstan, Almaty, Elebekova street 10, B.3 Office no. 103 TEL : +7-727-355-7133

---

**India Branch Office** #4/169, 1st Floor, LOTTE BLDG, Rajiv Gandhi Salai, (OMR), Kandanchavadi, Chennai - 600096, Tamilnadu, India TEL : +91-76-0490-3348