

LM TT Series

LM1600TTSY | LM1800TTSY

HYUNDAI WIA CNC Multi Axis Turning Center

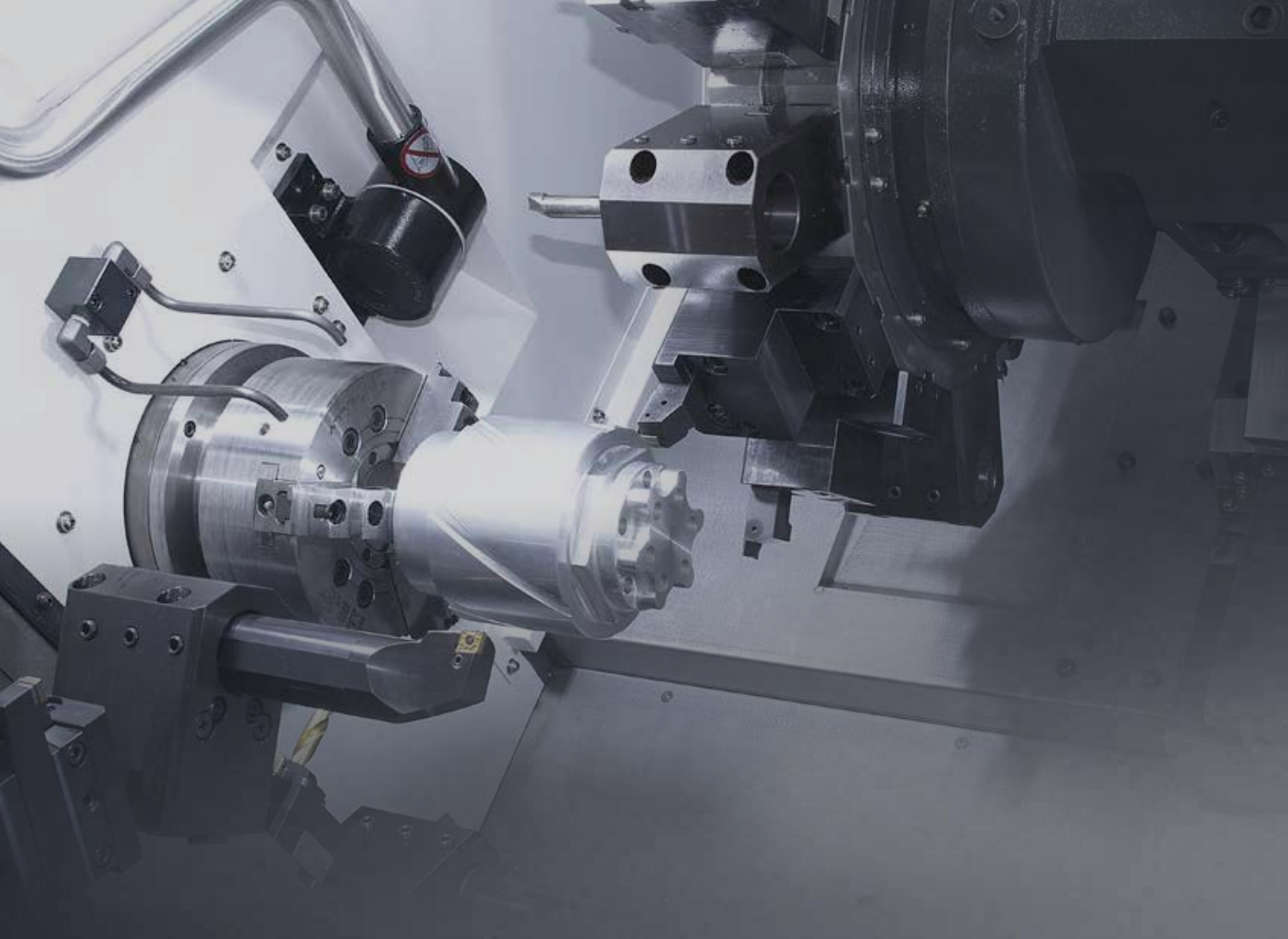

Technical Leader

The CNC Turning Center LM-TT Series, designed by Hyundai WIA with years of expertise and the latest technology, is designed to maximize productivity by utilizing twin spindles and twin turrets.

ITEM	Right Spindle		Left Spindle		Turret		Y-Axis
	6"	8"	6"	8"	Standard	Turn Mill	
LM1600TTS	•		•		•		
LM1600TTMS	•		•			•	
LM1600TTSY	•		•			•	•
LM1800TTS		•		•	•		
LM1800TTMS		•		•		•	
LM1800TTSY		•		•		•	•

LM TT Series

Twin Spindle & Turret – Multitasking CNC Turning Center

- High power built-in spindle motor
- Use of twin turrets guarantees high productivity
- High rigidity BMT turret
- Multiple processing is possible with the addition of Y-axis on the upper turret (TTSY Series)
- Integrated processing through synchronized control of twin spindles
- Hybrid travel system achieved by combination of box and roller guideways.



01 BASIC STRUCTURE

Right/Left Spindle and Turret for High Productivity – Versatile CNC Turning Center

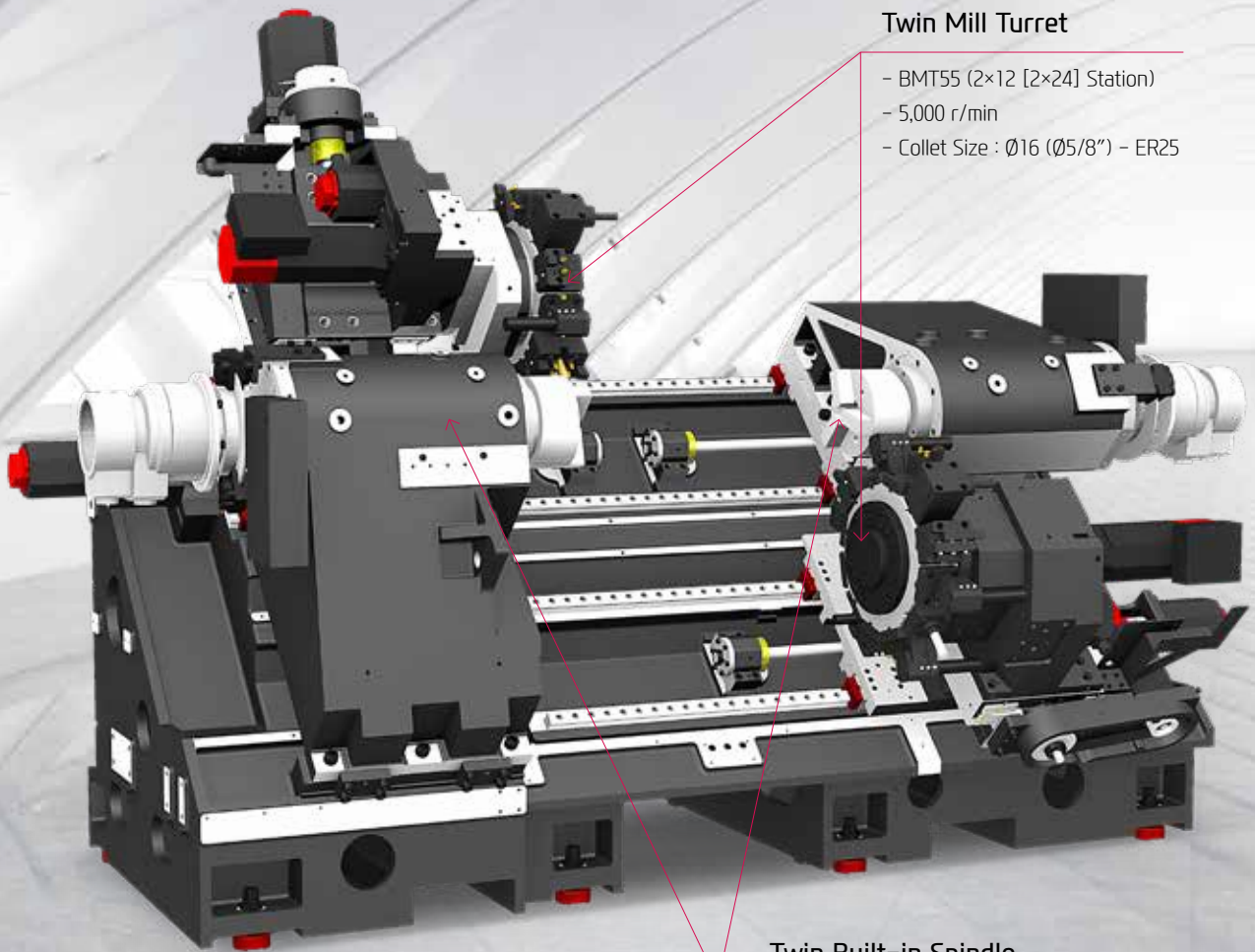

Twin Mill Turret

- BMT55 (2×12 [2×24] Station)
- 5,000 r/min
- Collet Size : Ø16 (Ø5/8") – ER25

Twin Built-in Spindle

- LM1600TTSY : 6" / 6,000 r/min
- LM1800TTSY : 8" / 5,000 r/min
- C-Axis Control : 0.001

REDUCTION OF NON-CUTTING TIME BY FAST RAPID SPEED

ALL-IN-ONE TYPE OF BED

High Precision, High Rigidity Bed Structure

The LM1600/1800TT Series features a one-piece 45° slant bed design based on FEM analysis to provide improvement in vibration absorption and thermal displacement. This unique design ensures stable and precise processing.

Floor Space **3,660×2,000** mm (L×W)
(144.1"×78.7")

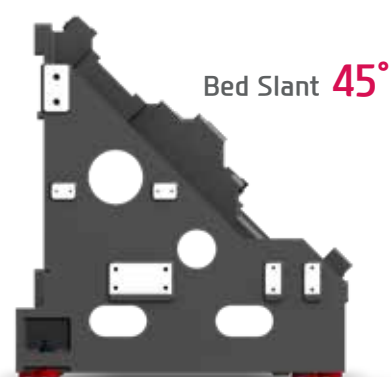

GUIDEWAY

Hybrid Slideway

Each axis on the LM1600TT/1800TT Series is designed with slideways that optimize the characteristics of the axis. For the X/Y-axis, box guideways are used to endure heavy load. For the Z-axis, roller type LM guideways are used to optimize feed capability.

Ball Screw

In order to eliminate thermal growth and increase accuracy, all axis are driven by high precision double anchored ballscrews.

Box Guide

Roller Type
LM Guide

Rapid Traverse Rate (X1/X2/Z1/Z2/Y/ZB)

20/20/40/40/7.5/40 m/min (787/787/1,575/1,575/295.3/1,575 ipm)

LM1600TT | LM1800TT Series Travel (X1/X2/Z1/Z2/Y) (ZB)

165/195/700/720/100 {±50} mm

(6.5"/7.7"/27.6"/28.3"/3.9" {±2"})

700 | 668 mm

(27.6" | 26.3")

MACHINING PROCESS WITH ONLY ONE INITIAL SETTING

Y-AXIS

Wedge Type Y-Axis Structure

The LM-TT Series is designed with a wedge type Y-axis that is transferred by the simultaneous operation of the Ys-axis and the X-axis.

In addition, excellent rigidity makes it possible to perform superb quality when machining a heavy-duty cutting.

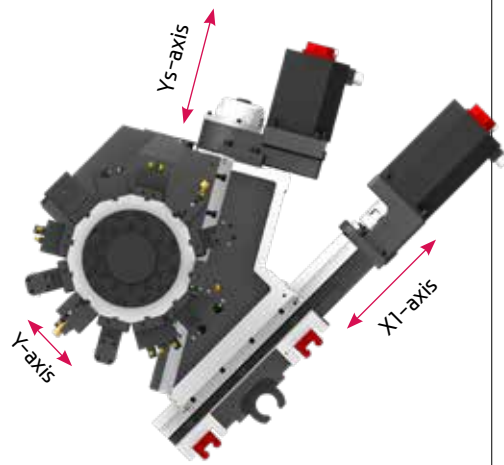

- ⦿ Y-axis Rapid Traverse Rate : 7.5 m/min (295.3 ipm)
- ⦿ Y-axis Travel : 100 {±50} mm (3.9" {±2"})

TWIN SPINDLE AND TWIN TURRET FOR MULTIFLEXIBILITY

LM-TT Series demonstrates Hyundai-WIA's technological capability by machining any type of complex parts with twin spindles, twin turrets and additional Y-axis.

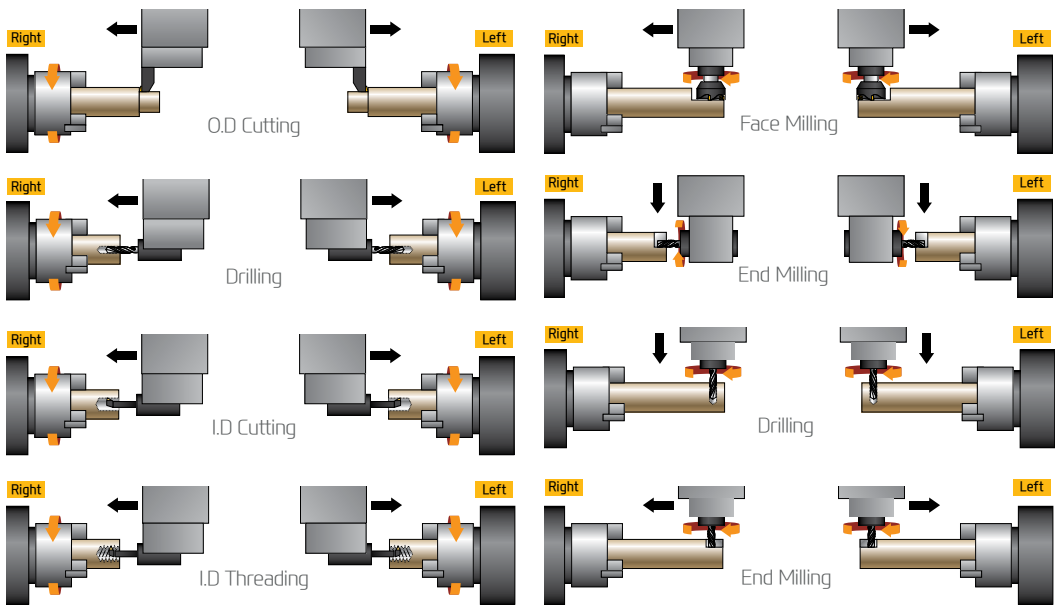

03 HIGH PRECISION SPINDLE

Long Lasting, High Accuracy & Excellent Performance CNC Turning Center

Spindle Specifications

[] : Option

Model	Spindle Speed	Motor (Max./Cont.)	Torque (Max.)	Controller
LM1600TT Series	6,000 rpm	15/11 kW (20/15 HP)	208 N·m (153.4 lbft·ft)	FANUC
LM1800TT Series	5,000 rpm	22/11 kW (30/15 HP)	358 N·m (264 lbft·ft)	
LM1800TTSY	[5,000 rpm]	[21.4/19.6 kW (28.7/26.3 HP)]	[220 N·m (162.3 lbft·ft)]	[SIEMENS]

RIGHT/LEFT BUILT-IN SPINDLE FOR HIGH PRODUCTIVITY

SPINDLE

Built-in Spindle

LM-TT Series right/left spindle are built-in, thereby minimizing noise and vibration even during high speed operations. The built-in spindle is capable of rapid acc/ deceleration and stable heavy duty cutting.

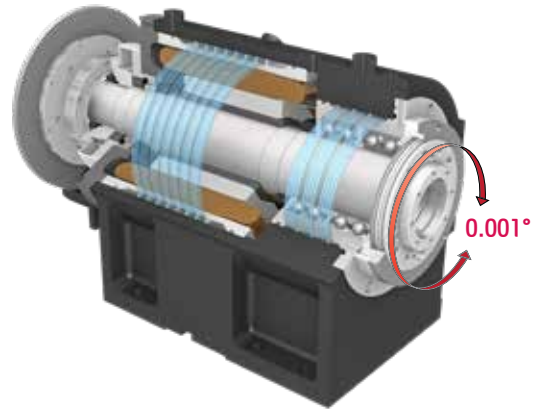

Left Spindle

Machines with a left spindle can perform secondary operations with a single setup, increasing flexibility and productivity.

Spindle Oil Cooling

The LM-TT Series features a spindle cooling system on both right/left spindles as standard. This system minimizes thermal growth during operations and helps to maintain stable machining environment.

C-Axis Control

LM-TT models featuring milling are equipped with full C-axis(0.001°) capability on both spindles.

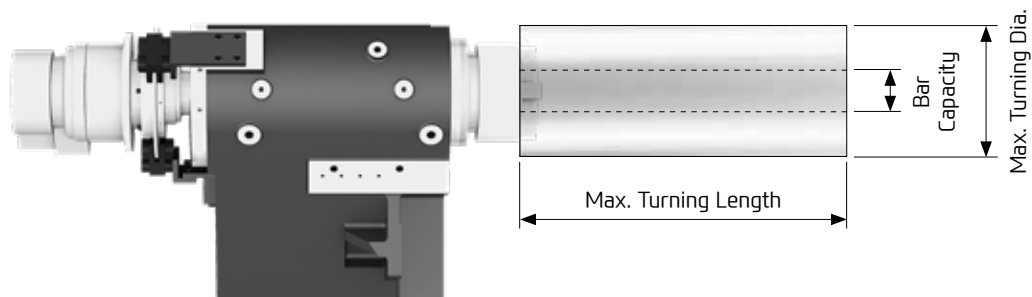

Model	Chuck Size	Max. Turning Length	Max. Turning Dia.	Bar Capacity
LM1600 Series	6"	705 mm (27.8")	Ø230 mm (9.1")	Ø51 mm (2")
LM1800 Series	8"	673 mm (26.5")	Ø230 mm (9.1")	Ø65 mm (2.6")

LM-TT SERIES

04 BMT TURRET

High speed, High Accuracy, Highly Reliable BMT Turret



VARIOUS DRIVEN PRECISION BMT TOOL HOLDERS

TURRET

Mill Turret

The upper and the lower turrets are equipped with powerful servo motors, which guarantee high productivity and precision.

In particular, a total of 24 (Option 48) tools can be installed on both turrets, and high speed precision machining of complex products is possible with a single setup.

- ⦿ Speed (rpm) : 5,000 r/min
- ⦿ Collet size : $\varnothing 16$ ($\varnothing 5/8''$) {ER25}
- ⦿ Indexing Time : 0.15 sec

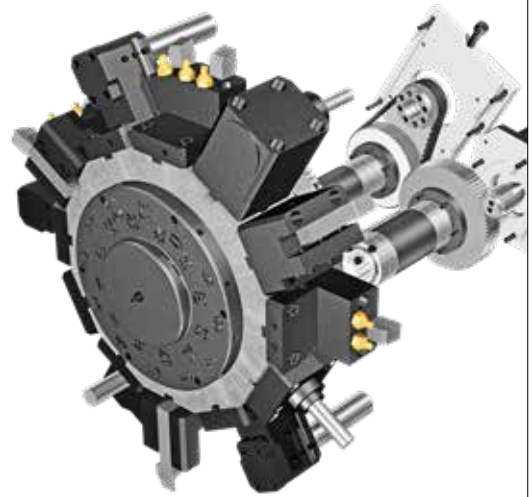

STRAIGHT MILLING HEAD



ANGULAR MILLING HEAD



Mill Tool Holder

Machining capability has increased with the addition of straight milling head tool holder, which can machine workpieces from the side, and angular milling head tool holder, which can perform I.D. operations.

SPECIAL TOOL

OPTION

With the Y-axis, the LM-TT series can process high value-added products using a variety of rotating tools. In particular, there is a multi-holder for attaching a variety of tools to one holder, and an eccentric rotary tool for handling eccentric parts without additional axis travel, which can realize integration of process with one machine.

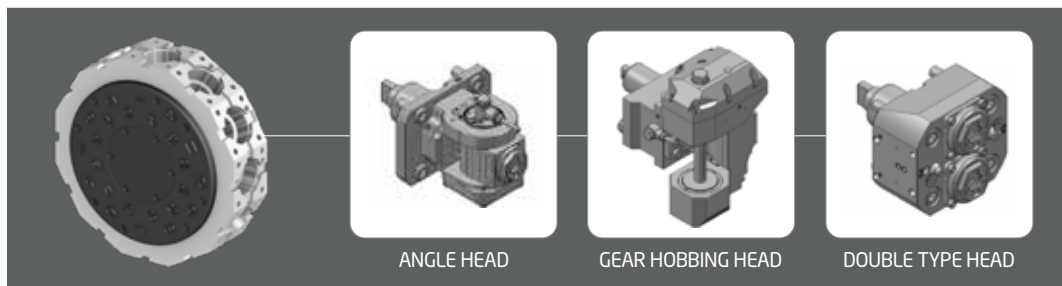

ANGLE HEAD

GEAR HOBGING HEAD

DOUBLE TYPE HEAD

❖ Consultation needed when ordering these options.

05 USER CONVENIENCE

Various Devices for User Friendly

BAR FEEDER SYSTEM

Bar Feeder

Bar feeder system enables automation which leads to efficiency improvement.

Parts Conveyor

The parts conveyor transfers the finished workpiece unloaded by the parts catcher for user convenience.



COOLANT UNIT



Standard Coolant (Nozzle)



Chuck Coolant (Upper Chuck)



Chuck Air Blow (Upper Chuck)



Gun Coolant

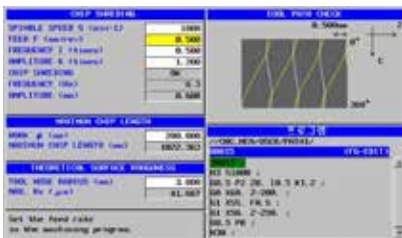

SERVO LEARNING OSCILLATION FUNCTION FOR CHIP BREAKING **OPTION**

- Machining Method : The tool cuts the workpiece moving in a zigzag pattern. (Oscillating) → Air cut section occurs → Long chips break
- Advantage : Increase tool life, Enhance surface finishing, Improve chip disposal
- Machine : All turning centers with FANUC controller (Option)

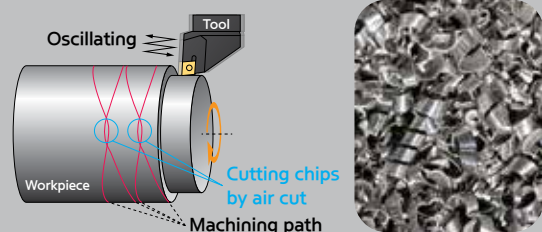

(Developed special screen page for servo learning oscillation function / Even when this function is applied, the cycle time remains same.)

Optional

HIGH PRECISION SYSTEM



Automatic Q-Setter

Cutting tools are calibrated quickly and accurately with the addition of a q-setter. Each tool tip is touched off manually using a sensor that inputs the position automatically.



Linear Scale **OPTION**

Linear scales increase positioning accuracy and reduce distortion caused by thermal growth, thus ensuring a more accurate finished part. (LM1600/1800 Series)



Work Probe **OPTION**

Workpiece coordinate values can be set automatically using the optional spindle probe.

CHIP DISPOSAL SOLUTION

Chip Conveyor

Timely and effective disposal of chips will enhance productivity as well as the working environment.



Hinge	Chip Type : Roughing Chip, Long Chip, Chip complex	Material : SS41, 45C, Cast Steel	Front-Right Direction
	Highly efficient when disposing a lot of chips. Capable of handling stringy chips..		
Scraper	Chip Type : Finely broken chip blown out	Material : cast Iron, Nonferrous	
	Convenient for shortly cut chips.		
❖ Drum Filter	Chip Type : Powder, Micro Chip	Material : AL	
	Advantageous in precision, as the chips do not flow in to the coolant nozzle.		

❖ When ordering a drum filter chip conveyor, prior consult with hyundai wia's sales person.

SPECIFICATIONS

LM1600TT Series Standard & Optional

● : Standard ○ : Option ☆ : Prior Consultation - : Non Applicable

Spindle		TTS	TTMS	TTSY
Right Spindle	6"	●	●	●
Hollow Chuck 3 Jaw	8"	-	-	-
Right Spindle	6"	○	○	○
Solid Chuck 3 Jaw	8"	-	-	-
Left Spindle	6"	●	●	●
Hollow Chuck 3 Jaw	8"	-	-	-
Left Spindle	6"	○	○	○
Solid Chuck 3 Jaw	8"	-	-	-
Standard Soft Jaw (1set)		●	●	●
Chuck Clamp Foot Switch		●	●	●
2 Steps Hyd. Pressure Device		○	○	○
Spindle Inside Stopper		○	○	○
5" Index		-	-	-
Cs-Axis (0.001")		○	●	●
Turret				
Tool Holder	2×12ea	●	●	●
	2×12ea	○	○	○
Mill Turret	BMT	-	●	●
Straight Milling Head	Adapter Type, 2ea	-	●	●
Angular Milling Head	Adapter Type, 2ea	-	●	●
Boring Sleeve		●	●	●
Drill Socket		●	●	●
U-Drill Holder		●	●	●
Angle Head		-	☆	☆
Tail Stock & Steady Rest				
Built in Programmable Tail Stock		-	-	-
Manual Hyd. Steady Rest		-	-	-
Coolant & Air Blow				
Standard Coolant (Nozzle)		●	●	●
Chuck Coolant (Upper Chuck)		☆	☆	☆
Gun Coolant		-	-	-
Through Spindle Coolant (Only for Special Chuck)		☆	☆	☆
Thru Coolant for Live Tool		-	☆	☆
Chuck Air Blow (Upper Chuck)		●	●	●
Left Spindle Air Blow		●	●	●
Tail Stock Air Blow (Upper Tail Stock)		-	-	-
Turret Air Blow		☆	☆	☆
Air Gun		○	○	○
Through Spindle Air Blow (Only for Special Chuck)		☆	☆	☆
High Pressure Coolant	0.5Bar (7.2psi)	●	●	●
	6Bar (87psi)	○	○	○
	20Bar (290psi)	○	○	○
	70Bar (1,015psi)	○	○	○
Power Coolant System (For Automation)		☆	☆	☆
Coolant Chiller		☆	☆	☆
Chip Disposal				
Coolant Tank	300 ℓ (79.3 gal)-Side	●	●	●
	230 ℓ (60.8 gal)-Rear	○	○	○
Chip Conveyor (Hinge/Scraper)	Front (Rear)	○	○	○
	Front (Right)	○	○	○
Special Chip Conveyor (Drum Filter)		☆	☆	☆
Chip Wagon	Standard (180 ℓ [47.5 gal])	○	○	○
	Swing (200 ℓ [52.8 gal])	○	○	○
	Large Swing (290 ℓ [76.6 gal])	○	○	○
	Large Size (330 ℓ [87.2 gal])	○	○	○
	Customized	☆	☆	☆
Safety Device				
Back Spin Torque Limiter (BST)		●	●	●
Total Splash Guard		●	●	●
Chuck Hydraulic Pressure Maintenance Interlock		☆	☆	☆

Electric Device		TTS	TTMS	TTSY
Call Light	1Color : ●	○	○	○
Call Light & Buzzer	3Color : ●●●	●	●	●
Electric Cabinet Light		○	○	○
Remote MPG		●	●	●
Work Counter	Digital	○	○	○
Total Counter	Digital	○	○	○
Tool Counter	Digital	○	○	○
Multi Tool Counter	Digital	○	○	○
Electric Circuit Breaker		○	○	○
AVR (Auto Voltage Regulator)		☆	☆	☆
Transformer	50kVA	○	-	-
	60kVA	-	○	○
Auto Power Off)		○	○	○
Measurement				
Q-Setter		☆	☆	☆
Automatic Q-Setter		●	●	●
Work Close Confirmation Device (Only for Special Chuck)	TACO	○	○	○
	SMC	○	○	○
Work Setter		☆	☆	☆
HWTM (Tool Monitoring System)		○	○	○
Linear Scale	X Axis	○	○	○
	Z Axis	○	○	○
	Y Axis	○	○	○
Coolant Level Sensor(Only for Chip Conveyor)		☆	☆	☆
Environment				
Air Conditioner		○	○	○
Oil Mist Collector		☆	☆	☆
Oil Skimmer (Only for Chip Conveyor)		○	○	○
MQL (Minimal Quantity Lubrication)		☆	☆	☆
Fixture & Automation				
Auto Door	Standard	○	○	○
	High Speed	○	○	○
Auto Shutter (Only for Automatic System)		☆	☆	☆
Sub Operation Panel		☆	☆	☆
Bar Feeder Interface		○	○	○
Bar Feeder		☆	☆	☆
Left Sp. Work Eject (Pneumatic Type)		○	○	○
Left Sp. Work Pusher (Pneumatic Type)		○	○	○
Extra M-Code 4ea		○	○	○
Automation Interface		☆	☆	☆
I/O Extension (IN & OUT)	16 Contact	○	○	○
	32 Contact	○	○	○
Parts Catcher	Right SP.	○	○	○
	Left SP.	-	-	-
Parts Unloader (Left Sp.) + Parts Conveyor		○	○	○
Left Sp. Work Pusher (Spring Type)		○	○	○
Turret Work Pusher (For Automation)		☆	☆	☆
Parts Conveyor		○	○	○
Hyd. Device				
Standard Hyd. Cylinder	Hollow	●	●	●
Standard Hyd. Unit	35bar (507.6psi) / 20 ℓ (5.3 gal)	●	●	●
S/W				
Dialogue Program (HW-DPRO) : FANUC		-	-	-
DNC software (HW-eDNC)		○	○	○
Machine Monitoring System (HW-MMS Cloud)		☆	☆	☆
Smart Guide-i : FANUC		☆	☆	☆
Smart S/W		☆	☆	☆
ETC				
Tool Box		●	●	●
Customized Color	Need Munsel No.	☆	☆	☆
CAD & CAM		☆	☆	☆

❖ Thermal Displacement Compensation device is recommended, when more than 6 bar of high pressure coolant is applied, for the high quality machining.

Specifications are subject to change without notice for improvement. / Please refer to the S/W catalog (iRIS) for details by S/W product.

SPECIFICATIONS

LM1800TT Series Standard & Optional

● : Standard ○ : Option ☆ : Prior Consultation - : Non Applicable

Spindle		TTS	TTMS	TTSY
Right Spindle	8"	●	●	●
Hollow Chuck 3 Jaw	10"	-	-	-
Right Spindle	8"	○	○	○
Solid Chuck 3 Jaw	10"	-	-	-
Left Spindle	8"	●	●	●
Hollow Chuck 3 Jaw	10"	-	-	-
Left Spindle	8"	○	○	○
Solid Chuck 3 Jaw	10"	-	-	-
Standard Soft Jaw (1set)		●	●	●
Chuck Clamp Foot Switch		●	●	●
2 Steps Hyd. Pressure Device		○	○	○
Spindle Inside Stopper		○	○	○
5° Index		-	-	-
Cs-Axis (0.001°)		○	●	●
Turret				
Tool Holder	2×12ea	●	●	●
	2×12ea	○	○	○
Mill Turret	BMT	-	●	●
Straight Milling Head	Adapter Type, 2ea	-	●	●
Angular Milling Head	Adapter Type, 2ea	-	●	●
Boring Sleeve		●	●	●
Drill Socket		●	●	●
U-Drill Holder		●	●	●
Angle Head		-	☆	☆
Tail Stock & Steady Rest				
Built in Programable Tail Stock		-	-	-
Manual Hyd. Steady Rest		-	-	-
Coolant & Air Blow				
Standard Coolant (Nozzle)		●	●	●
Chuck Coolant (Upper Chuck)		☆	☆	☆
Gun Coolant		-	-	-
Through Spindle Coolant (Only for Special Chuck)		☆	☆	☆
Thru Coolant for Live Tool		-	☆	☆
Chuck Air Blow (Upper Chuck)		●	●	●
Left Spindle Air Blow		●	●	●
Tail Stock Air Blow (Upper Tail Stock)		-	-	-
Turret Air Blow		☆	☆	☆
Air Gun		○	○	○
Through Spindle Air Blow (Only for Special Chuck)		☆	☆	☆
High Pressure Coolant	0.5Bar (7.2psi)	●	●	●
	6Bar (87psi)	○	○	○
	20Bar (290psi)	○	○	○
	70Bar (1,015psi)	○	○	○
Power Coolant System (For Automation)		☆	☆	☆
Coolant Chiller		☆	☆	☆
Chip Disposal				
Coolant Tank	300 ℓ (79.3 gal)-Side	●	●	●
	230 ℓ (60.8 gal)-Rear	○	○	○
Chip Conveyor (Hinge/Scraper)	Front (Rear)	○	○	○
	Front (Right)	○	○	○
Special Chip Conveyor (Drum Filter)		☆	☆	☆
Chip Wagon	Standard (180 ℓ [47.5 gal])	○	○	○
	Swing (200 ℓ [52.8 gal])	○	○	○
	Large Swing (290 ℓ [76.6 gal])	○	○	○
	Large Size (330 ℓ [87.2 gal])	○	○	○
	Customized	☆	☆	☆
Safety Device				
Back Spin Torque Limiter (BST)		●	●	●
Total Splash Guard		●	●	●
Chuck Hydraulic Pressure Maintenance Interlock		☆	☆	☆

Electric Device		TTS	TTMS	TTSY
Call Light	1Color : ●	○	○	○
Call Light & Buzzer	3Color : ●●●	●	●	●
Electric Cabinet Light		○	○	○
Remote MPG		●	●	●
Work Counter	Digital	○	○	○
Total Counter	Digital	○	○	○
Tool Counter	Digital	○	○	○
Multi Tool Counter	Digital	○	○	○
Electric Circuit Breaker	FANUC	○	○	○
	SIEMENS	-	-	-
AVR (Auto Voltage Regulator)		☆	☆	☆
Transformer	50KVA	○	-	-
	60KVA	-	○	○
Auto Power Off		○	○	○
Measurement				
Q-Setter		☆	☆	☆
Automatic Q-Setter		●	●	●
Work Close Confirmation Device (Only for Special Chuck)	TACO	○	○	○
	SMC	○	○	○
Work Setter		☆	☆	☆
HWTM (Tool Monitoring System)				
Linear Scale	X Axis	○	○	○
	Z Axis	○	○	○
	Y Axis	○	○	○
Coolant Level Sensor(Only for Chip Conveyor)		☆	☆	☆
Environment				
Air Conditioner		○	○	○
Oil Mist Collector		☆	☆	☆
Oil Skimmer (Only for Chip Conveyor)		○	○	○
MQL (Minimal Quantity Lubrication)		☆	☆	☆
Fixture & Automation				
Auto Door	Standard	○	○	○
	High Speed	○	○	○
Auto Shutter (Only for Automatic System)		☆	☆	☆
Sub Operation Panel		☆	☆	☆
Bar Feeder Interface		○	○	○
Bar Feeder		☆	☆	☆
Left Sp. Work Eject (Pneumatic Type)		○	○	○
Left Sp. Work Pusher (Pneumatic Type)		○	○	○
Extra M-Code 4ea		○	○	○
Automation Interface		☆	☆	☆
I/O Extension (IN & OUT)	16 Contact	○	○	○
	32 Contact	○	○	○
Parts Catcher	Right SP.	○	○	○
	Left SP.	-	-	-
Parts Unloader (Left Sp.) + Parts Conveyor		○	○	○
Left Sp. Work Pusher (Spring Type)		○	○	○
Turret Work Pusher (For Automation)		☆	☆	☆
Parts Conveyor		○	○	○
Hyd. Device				
Standard Hyd. Cylinder	Hollow	●	●	●
Standard Hyd. Unit	35bar (507.6psi) / 20 ℓ (5.3 gal)	●	●	●
S/W				
Dialogue Program (HW-DPRO) : FANUC		-	-	-
DNC software (HW-eDNC)		○	○	○
Machine Monitoring System (HW-MMS Cloud)		☆	☆	☆
Smart Guide-i : FANUC		☆	☆	☆
Smart S/W		☆	☆	☆
ETC				
Tool Box		●	●	●
Customized Color	Need Munsel No.	☆	☆	☆
CAD & CAM		☆	☆	☆

❖ Thermal Displacement Compensation device is recommended, when more than 6 bar of high pressure coolant is applied, for the high quality machining.

Specifications are subject to change without notice for improvement. / Please refer to the S/W catalog (IRIS) for details by S/W product.

SPECIFICATIONS

Spindle Output/Torque Diagram

LM1600TT Series 6,000 rpm

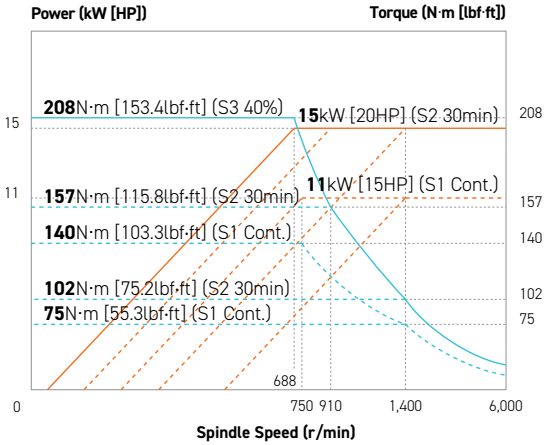

LM1800TT Series 5,000 rpm

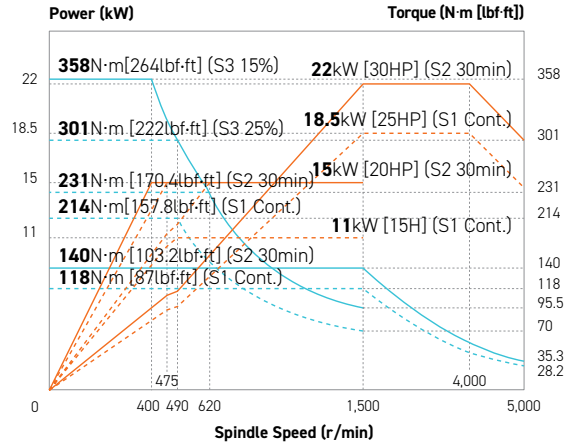

LM1800TTSY SIEMENS 5,000 rpm

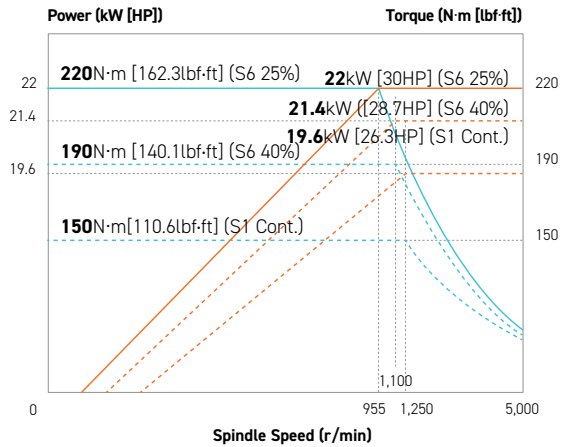

LM1600/1800TT Series Mill Sp. 5,000 rpm

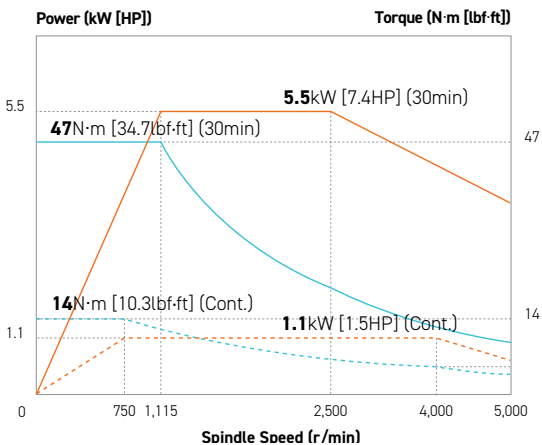

LM1800TTSY Mill Sp. SIEMENS 5,000 rpm

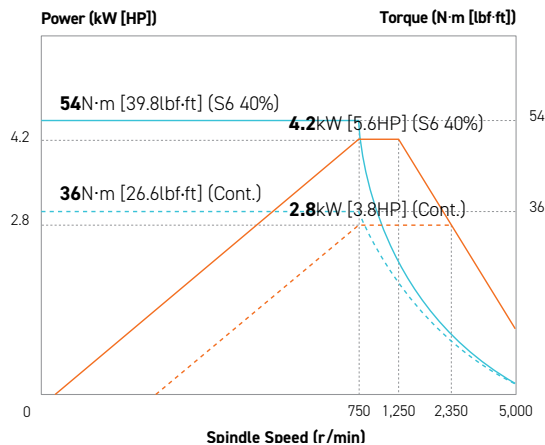

SPECIFICATIONS

External Dimensions

unit : mm(in)

LM1600TT/1800TT Series

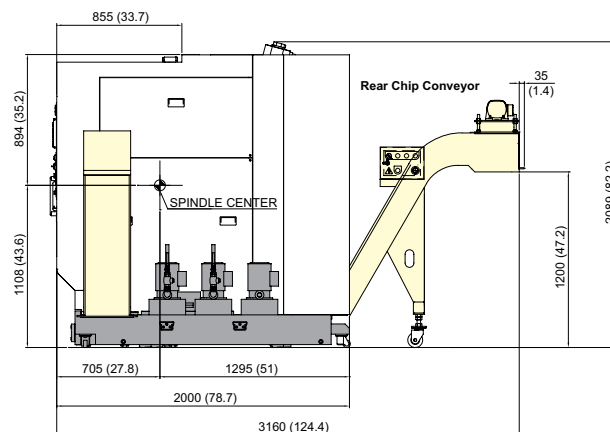
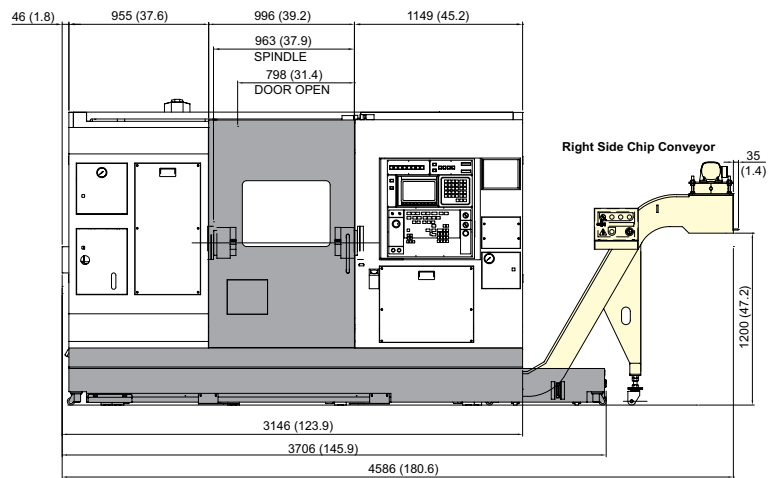
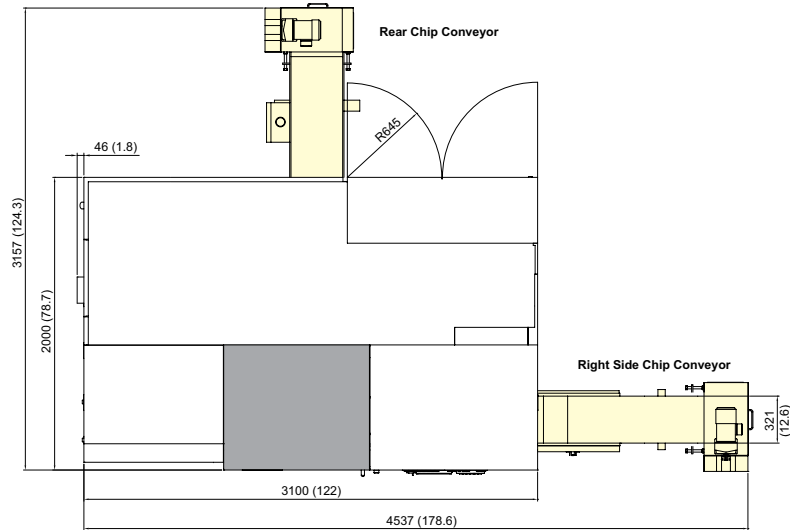

SPECIFICATIONS

Interference

unit : mm(in)

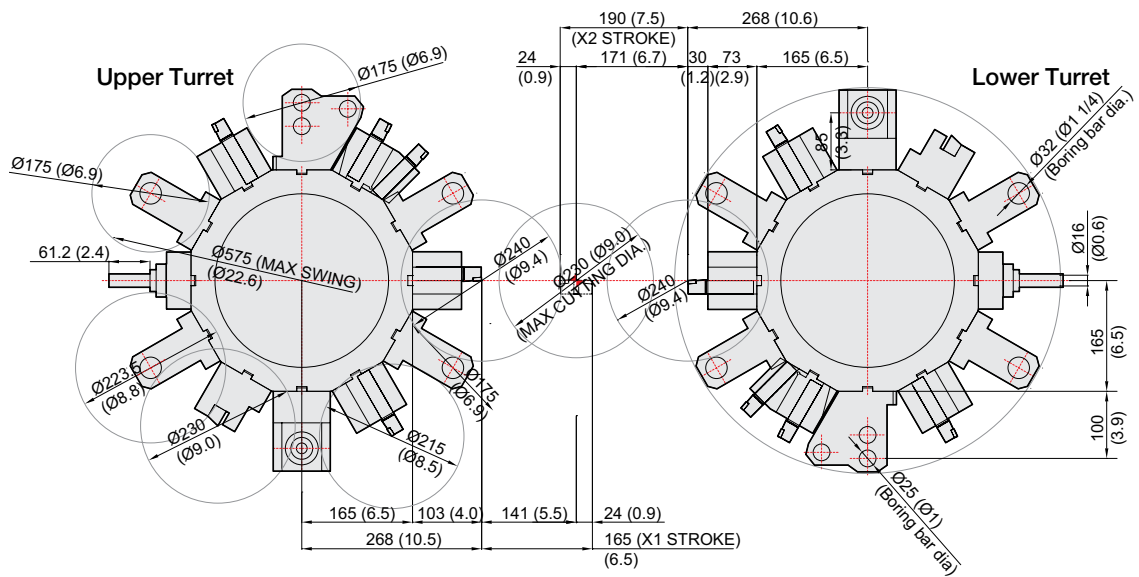

SPECIFICATIONS

Tooling System

unit : mm(in)

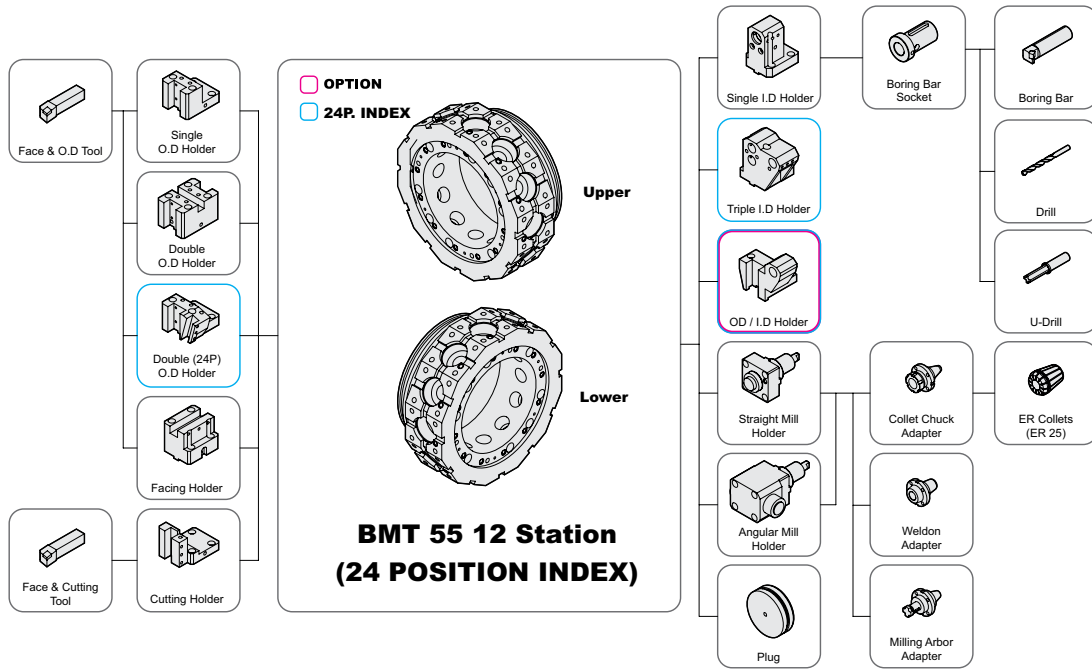

Tooling Parts Detail

ITEM			TTS		TTSY		TTMS	
			mm Unit	inch Unit	mm Unit	inch Unit	mm Unit	inch Unit
Turning Holder	O.D Holder	Right/Left	6	6	4	4	4	4
		Double	2	2	2	2	2	2
		Double (Side)	2	2	2	2	2	2
	Facing Holder		2	2	2	2	2	2
	O.D & I.D Holder		-	-	Opt.	Opt.	Opt.	Opt.
Cutting Holder		1	1	1	1	1	1	
Boring Holder	I.D Holder	Single	9	9	7	7	7	7
		Triple	2	2	2	2	2	2
	U-Drill Holder	Cap	9	9	7	7	7	7
Driven Holder	Straight Mill Holder	Standard	-	-	2	2	2	2
		TTC (Tool through Coolant)	-	-	Opt.	Opt.	Opt.	Opt.
	Angular Mill Holder	Standard	-	-	2	2	2	2
		TTC (Tool through Coolant)	-	-	Opt.	Opt.	Opt.	Opt.
Socket	Boring	Ø8 (Ø5/16")	2	2	2	2	2	2
		Ø10 (Ø3/8")	2	2	2	2	2	2
		Ø12 (Ø1/2")	2	2	2	2	2	2
		Ø16 (Ø5/8")	2	2	2	2	2	2
		Ø20 (Ø3/4")	2	2	2	2	2	2
		Ø25 (Ø1")	2	2	2	2	2	2
	Drill	MT 1 × MT 2	2	2	2	2	2	2
		MT 2	2	2	2	2	2	2
		MT 3	Opt.	Opt.	Opt.	Opt.	Opt.	Opt.
	ER Collet		-	-	1 Set	1 Set	1 Set	1 Set
Adapter Set		-	-	1 Set	1 Set	1 Set	1 Set	

Specifications are subject to change without notice for improvement.

SPECIFICATIONS

Tooling Travel Range

unit : mm(in)

LM1600TT Series

O.D Holder

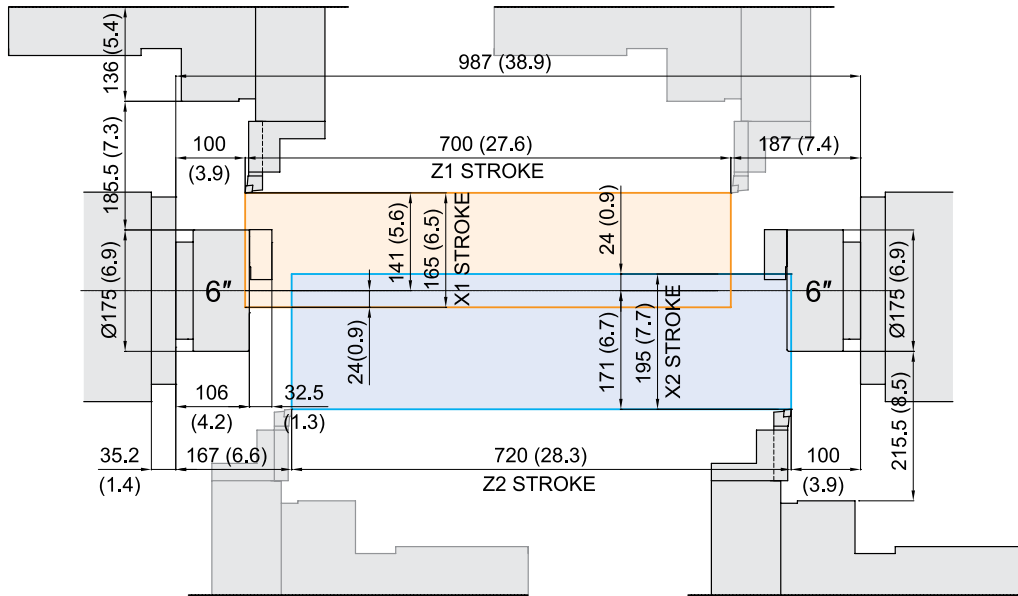

I.D Holder

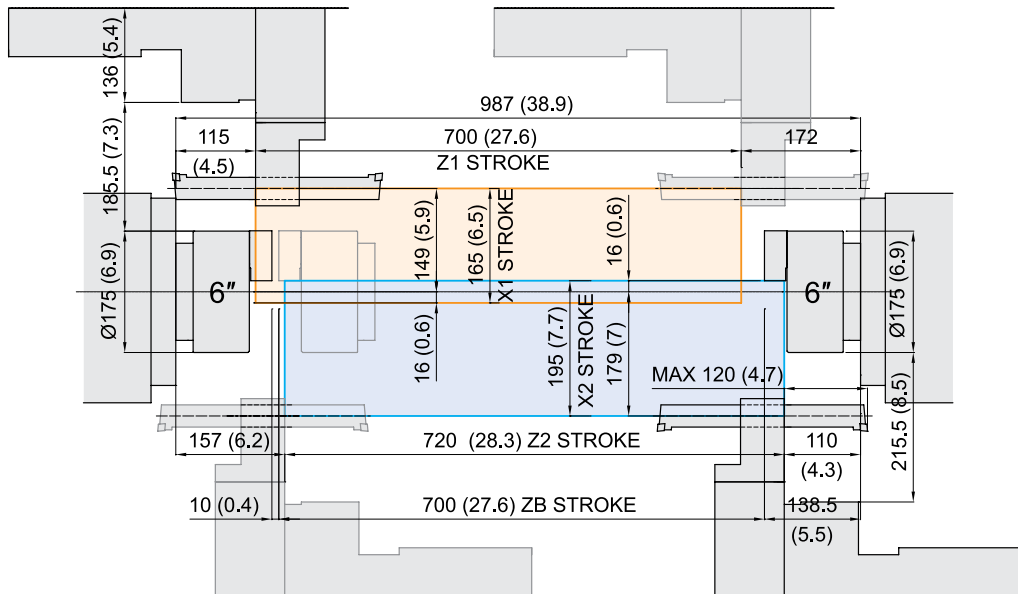

SPECIFICATIONS

Tooling Travel Range

unit : mm(in)

LM1600TT Series

Angular Mill Holder

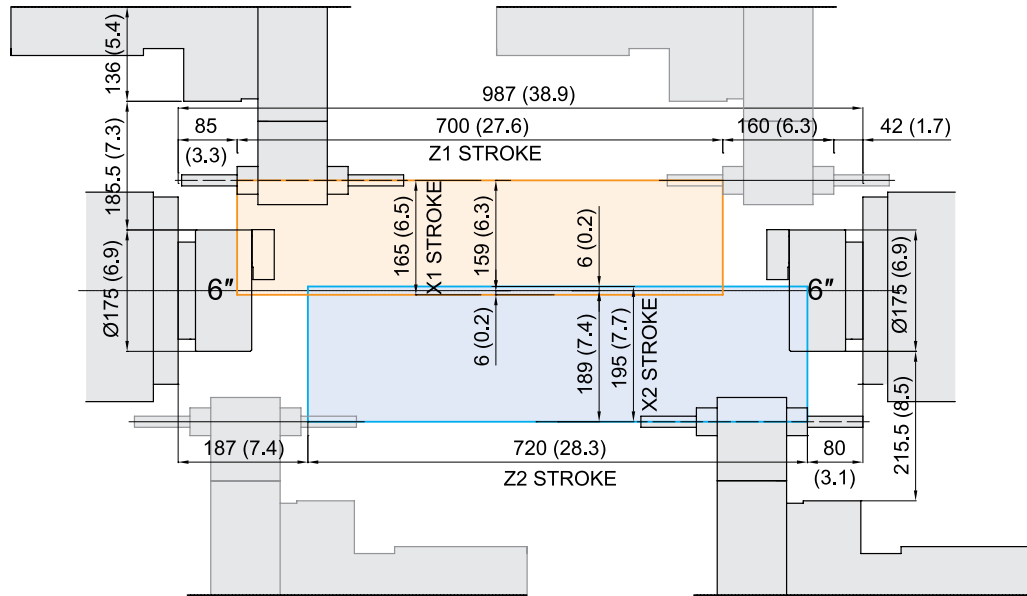

Straight Mill Holder

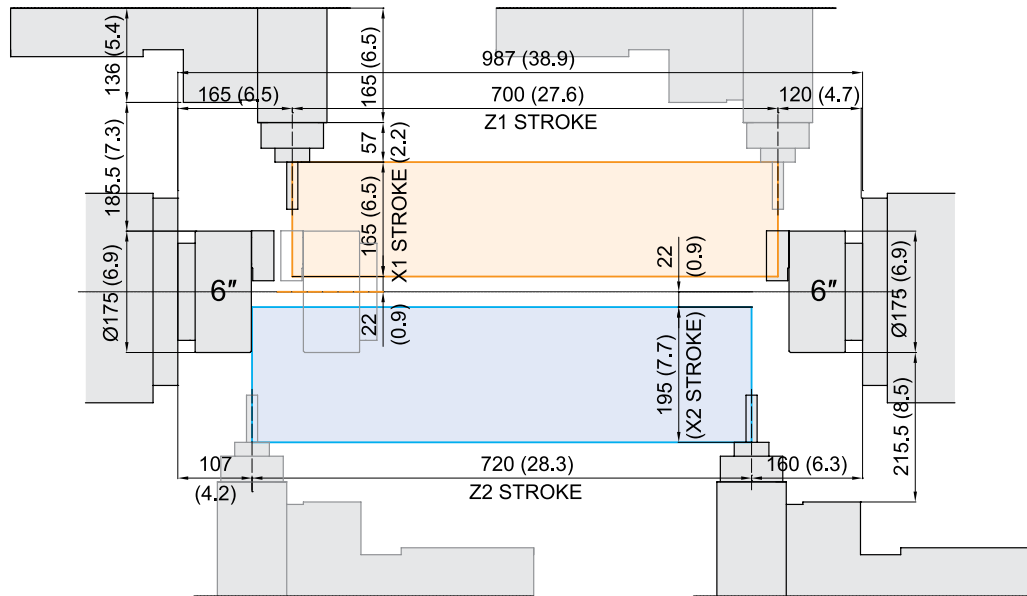

SPECIFICATIONS

Tooling Travel Range

unit : mm(in)

LM1800TT Series

O.D Holder

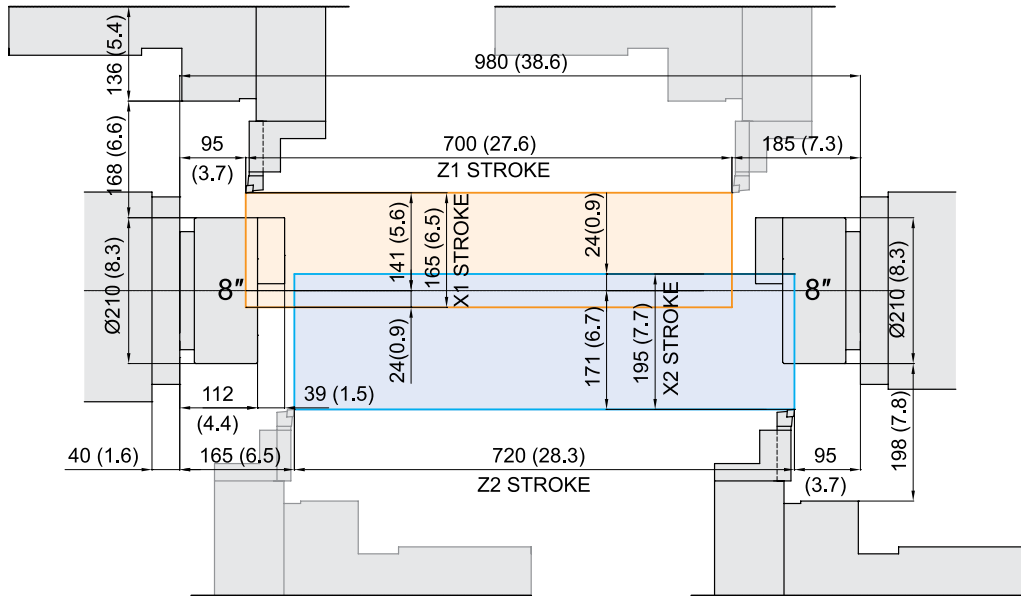

I.D Holder

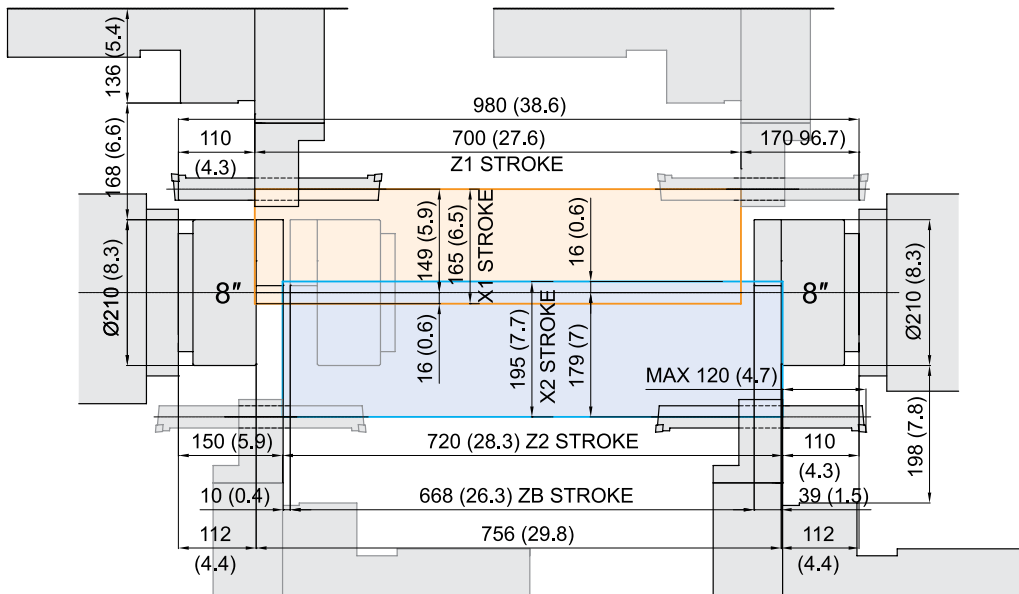

SPECIFICATIONS

Y-Axis Travel Range

unit : mm(in)

LM1600TT Series

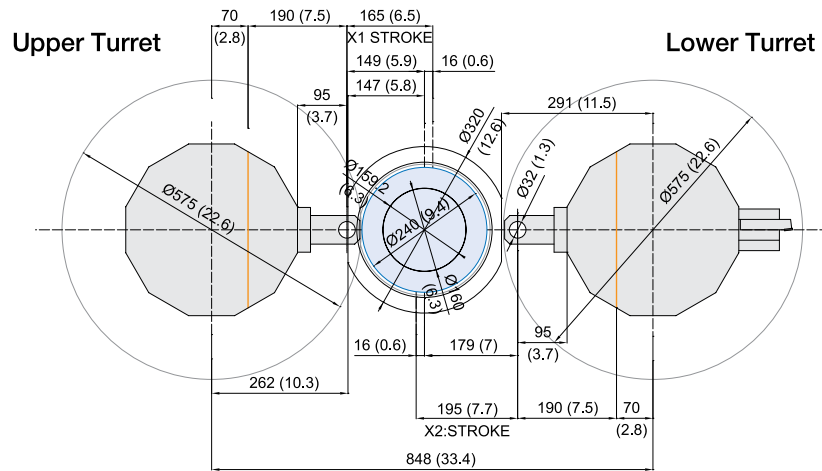

LM1800TT Series

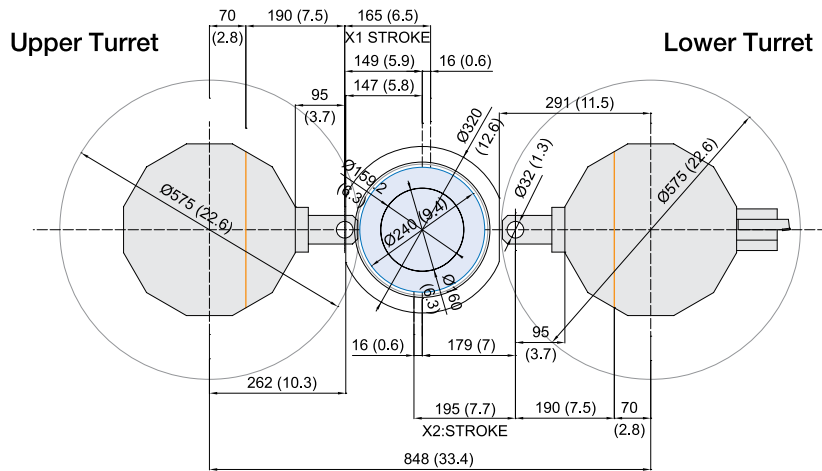

SPECIFICATIONS

Specifications

[] : Option

ITEM			LM1600TTS	LM1600TTMS	LM1600TTSY
CAPACITY	Swing Over the Carriage	mm(in)		Ø290 (11.4")	
	Max. Turning Dia.	mm(in)		Ø230 (9.1")	
	Max. Turning Length	mm(in)		705 (27.8")	
	Bar Capacity	1st/2nd mm(in)		Ø51 (2")	
SPINDLE	Chuck Size	1st/2nd mm(in)		Ø175 (6.9")	
	Spindle Bore	1st/2nd mm(in)		Ø62 (2.4")	
	Spindle Speed (rpm)	1st/2nd r/min		6,000	
	Motor (Max/Cont.)	1st/2nd kW(HP)		15/11 (20/15)	
	Torque (Max/Cont.)	1st/2nd N·m(lbf·ft)		208/140 (153.4/103.3)	
	Spindle Type	1st/2nd -		Built-in Motor	
	Spindle Nose	1st/2nd -		A2-5	
	C-axis Indexing	1st/2nd deg	-		0.001°
FEED	Travel	X1/X2 mm(in)		165/195 (6.5"/7.7")	
		Z1/Z2 mm(in)		700/720 (27.6"/28.3")	
		Y mm(in)	-		100 {±50} (3.9")
		ZB mm(in)		700 (27.6")	
	Rapid Traverse Rate	X1/X2 m/min(ipm)		20/20 (787/787)	
		Z1/Z2 m/min(ipm)		40/40 (1,575/1,575)	
		Y m/min(ipm)	-		7.5 (295.3)
		ZB m/min(ipm)		40 (1,575)	
	Slide Type	X/Y -		BOX GUIDE	
		Z -		LM GUIDE	
TURRET	No. of Tools	EA		2x12 [2x24]	
	Tool Size	OD mm(in)		□ 20 (0.8")	
		ID mm(in)		Ø32 (1.3")	
	Indexing Time	sec/step		0.15	
	Y-Axis Type	-	-		Wedge Type
LIVE TOOL	Motor (Max/Cont.)	kW(HP)	-	5.5/1.1 (7.4/1.5)	
	Milling Tool Speed (rpm)	r/min	-	5,000	
	Torque (Max/Cont.)	N·m(lbf·ft)	-	47/14 (34.7/10.3)	
	Collet Size	mm(in)	-	Ø16 (0.6") ER25	
	Type	-	-		BMT55
TANK CAPACITY	Coolant Tank	ℓ (gal)		300 (79.3)	
	Lubricating Tank	ℓ (gal)		4 (1.06)	
POWER SUPPLY	Electric Power Supply	kVA	43		49
	Thickness of Power Cable	mm ²		OVER 50	
	Voltage	V/Hz		220/60 (200/50*)	
MACHINE	Floor Space (L×W)	mm(in)		3,660×2,000 (144.1"×78.7")	
	Height	mm(in)		2,089 (82.2")	
	Weight	kg(lb)	7,900 (17,417)	8,200 (18,078)	8,400 (18,519)
PC	Controller	-		FANUC 31i-B Plus	

*) Using 50Hz voltage instead of 60Hz may lower the output of motors. (excluding servo motors and inverter motors)
Specifications are subject to change without notice for improvement.

SPECIFICATIONS

Specifications

[] : Option ■ : SIEMENS

ITEM			LM1800TTS	LM1800TTMS	LM1800TTSY	
CAPACITY	Swing Over the Carriage	mm(in)		Ø290 (11.4")		
	Max. Turning Dia.	mm(in)		Ø230 (9.1")		
	Max. Turning Length	mm(in)		673 (26.5")		
	Bar Capacity	1st/2nd mm(in)		Ø65 (2.6")		
SPINDLE	Chuck Size	1st/2nd mm(in)		Ø210 (8.3")		
	Spindle Bore	1st/2nd mm(in)		Ø76 (3")		
	Spindle Speed (rpm)	1st/2nd r/min		5,000	5,000 [5,000]	
	Motor (Max/Cont.)	1st/2nd kW(HP)		22/11 (30/15)	22/11 (30/15) [22/19.6 (30/26.3)]	
	Torque (Max/Cont.)	1st/2nd N·m(lbf·ft)		358/214 (264/157.8)	358/214 (264/157.8) [220/150 (162.3/64.2)]	
	Spindle Type	1st/2nd -		Built-in Motor		
	Spindle Nose	1st/2nd -		A2-6		
	C-axis Indexing	1st/2nd deg		-	0.001*	
FEED	Travel	X1/X2 mm(in)		165/195 (6.5"/7.7")		
		Z1/Z2 mm(in)		700/720 (27.6"/28.3")		
		Y mm(in)		-	100 {±50} (3.9")	
		ZB mm(in)			668 (26.3")	
	Rapid Traverse Rate	X1/X2 m/min(ipm)			20/20 (787/787)	
		Z1/Z2 m/min(ipm)			40/40 (1,575/1,575)	
		Y m/min(ipm)			-	7.5 (295.3)
		ZB m/min(ipm)			40 (1,575)	
Slide Type	X/Y -			BOX GUIDE		
	Z -			LM GUIDE		
TURRET	No. of Tools	EA		2x12 [2x24]		
	Tool Size	OD mm(in)		□ 20 (0.8")		
		ID mm(in)			Ø32 (1.3")	
	Indexing Time	sec/step		0.15		
Y-Axis Type	-		-	Wedge Type		
LIVE TOOL	Milling Tool Speed (rpm)	r/min	-	5,000	5,000 [5,000]	
	Motor (Max/Cont.)	kW(HP)	-	5.5/1.1 (7.4/1.5)	5.5/1.1 (7.4/1.5) [4.2/2.8 (5.6/3.8)]	
	Torque (Max/Cont.)	N·m(lbf·ft)	-	47/14 (34.7/10.3)	47/14 (34.7/10.3) [54/36 (39.8/7.6)]	
	Collet Size	mm(in)	-	Ø16 (0.6") ER25		
	Type	-	-	BMT55		
TANK CAPACITY	Coolant Tank	ℓ (gal)		300 (79.3)		
	Lubricating Tank	ℓ (gal)		4 (1.06)		
POWER SUPPLY	Electric Power Supply	kVA		53	60	
	Thickness of Power Cable	mm ²		OVER 50		
	Voltage	V/Hz		220/60 (200/50*)		
MACHINE	Floor Space (L×W)	mm(in)		3,660×2,000 (144.1"×78.7")		
	Height	mm(in)		2,089 (82.2")		
	Weight	kg(lb)	8,000 (17,637)	8,300 (18,298)	8,500 (18,739)	
PC	Controller	-		FANUC 31i-B Plus	FANUC 31i-B Plus [SIEMENS 840D]	

*) Using 50Hz voltage instead of 60Hz may lower the output of motors. (excluding servo motors and inverter motors)
Specifications are subject to change without notice for improvement.

CONTROLLER

FANUC 31i-B Plus

[] : Option

Controlled axis / Display / Accuracy Compensation	
Control axis	4 axis (X, Z, Y, C) / 6 axis (X, Z, Y, B, C, A) 7 axis (X1/Z1, X2/Z2, B2, C1/C2) 8 axis (X1/Z1, X2/Z2, Y1, B2, C1/C2)
Simultaneously controlled axis	2 axis [Max. 4 axis]
Designation of spindle axis	4 axis (1 path), 6 axis (2 path Total)
Least setting Unit	X, Z, Y, B axis : 0.001 mm (0.0001 inch) C, A axis : 0.001 deg
Least input increment	X, Z, Y, B axis : 0.001 mm (0.0001 inch) C, A axis : 0.001 deg
Inch / Metric conversion	G20 / G21
High response vector control	
Interlock	All axis / Each axis
Machine lock	All axis
Backlash compensation	± 0 ~ 9999 pulses (Rapid traverse / Cutting feed)
Position switch	
LCD / MDI	15 inch color LCD
Feedback	Absolute motor feedback
Stored stroke check 1	Over travel
Stored stroke check 2, 3	
PMC axis control	
Operation	
Automatic operation (Memory)	
MDI operation	
DNC operation	Needed DNC software / CF card
Program restart	
Wrong operation prevention	
Program check function	Dry run, Program check
Single block	
Search function	Program Number / Sequence Number
Interpolation functions	
Piano interpolation	
Positioning	G00
Linear interpolation	G01
Circular interpolation	G02, G03
Helical interpolation	
Exact stop mode	Single : G09, Continuous : G61
Dwell	G04, 0 ~ 9999.9999 sec
Skip	G31
Reference position return	1st reference : G28 / 2nd reference : G30 Ref. position check : G27
Thread synchronous cutting	
Thread cutting retract	
Variable lead thread cutting	
Multi / Continuous threading	
Feed function / Acc. & Dec. control	
	Rapid traverse
Manual feed	Jog : 0~2,000 mm/min (79 ipm) Manual handle : x1, x10, x100 pulses Reference position return
Cutting Feed command	Direct input F code
Feedrate override	0 ~ 200% (10% Unit)
Rapid traverse override	F1%, F25%, 50%, F100%
Override cancel	
Feed per minute	G98
Feed per revolution	G99
Look-ahead block	1 block
Program input	
Tape Code	EIA / ISO
Optional block skip	9 ea
Program stop / end	M00, M01 / M02, M30
Maximum command unit	± 999,999.999 mm (± 99,999.9999 inch)
Plane selection	X-Y : G17 / Z-X : G18 / Y-Z : G19
Workpiece coordinate system	G52, G53, 6 pairs (G54 ~ G59)
Manual absolute	Fixed ON
Programmable data input	G10
Sub program call	10 folds nested
Custom macro	#100 ~ #149, #500 ~ #549
G code system	A/B/C
Programmable mirror image	G51.1, G50.1
G code preventing buffering	G4.1
Direct drawing dimension program	Including Chamfering / Corner R

Program input	
Multiple repetitive cycles	I, II
Canned cycle for turning	
Manual Guide i	Conversational auto program
Auxiliary function / Spindle speed function	
Auxiliary function	M 4 digit
Level-up M Code	High speed / Multi / Bypass M code
Spindle speed function	S 4 digit, Binary output
Spindle override	0% ~ 150% (10% Unit)
Multi position spindle orientation	M19
Rigid tapping	
Constant surface speed control	G96, G97
Tool function / Tool compensation	
Tool function	T 2 digit + Offset 2 digit
Tool life management	
Tool offset pairs	200 pairs
Tool nose radius compensation	G40, G41, G42
Geometry / Wear compensation	
Direct input of offset measured B	
Editing function	
Part program storage size	8M
No. of registerable programs	1000 ea
Program protect	
Background editing	
Extended part program editing	Copy, move and change of NC program
Memory card program edit	
Data input / output & Interface	
I/O interface	CF card, USB memory Embedded Ethernet interface
Screen hard copy	
External message	
External key input	
External workpiece number search	
Automatic data backup	
Setting, display and diagnosis	
Self-diagnosis function	
History display & Operation	Alarm & Operator message & Operation
Run hour / Parts count display	
Maintenance information	
Actual cutting feedrate display	
Display of spindle speed / T code	
Graphic display	
Operating monitor screen	Spindle / Servo load etc.
Power consumption monitoring	Spindle & Servo
Spindle / Servo setting screen	
Multi language display	Support 20 languages
Display language switching	Selection of 5 optional Languages
LCD Screen Saver	Screen saver
Unexpected disturbance torque	BST (Back spin torque limit)
Function for machine type	
Cs contour control (C & A axis)	Mill, MS, Y, SY, LF-Mill, TTMS, TTSY
Polar coordinate interpolation	Mill, MS, Y, SY, LF-Mill, TTMS, TTSY
Cylindrical interpolation	Mill, MS, Y, SY, LF-Mill, TTMS, TTSY
Polygon turning (2 Spindles)	Mill, MS, Y, SY, LF-Mill, TTMS, TTS
Canned cycle for drilling	Mill, MS, Y, SY, LF-Mill, TTMS, TTSY
Spindle orientation expansion	MS, SY TTS, TTMS, TTSY
Spindle synchronous control	MS, SY TTS, TTMS, TTSY
Torque control	MS, SY TTS, TTMS, TTSY
Y axis offset	Y, SY, TTSY
Arbitrary angular control	Y, SY, TTSY
Composite / Superimposed control	MS, SY TTS, TTMS, TTSY
Balance cutting	MS, SY TTS, TTMS, TTSY
Option	
Fast ethernet	Needed option board
Data server	Needed option board
Protection of data at 8 levels	
Dynamic graphic display	

Figures in inch are converted from metric values.

The FANUC controller specifications are subject to change based on the policy of company CNC supplying.

CONTROLLER

SIEMENS 840D sl

[] : Option ☆ Needed technical consultation

Controlled axis / Display / Accuracy Compensation	
Control axis	8 axis (X1, Y1, Z1, X2, Z2, B, C1, C2)
Simultaneously controlled axis	Max. 4 axis
Least setting Unit	X, Z, Y, B axis : 0.001 mm (0.0001 inch) C, A axis : 1 deg [0.001] deg
Least setting Unit	X, Z, Y, B axis : 0.001 mm (0.0001 inch) C, A axis : 1 deg [0.001] deg
Inch / Metric changeover	G70 (inch) / G71 (metric)
Interlock	All axis / Each axis
Machine lock	All axis
Backlash compensation	
Pitch error compensation	(Strategic material machine)
LCD / MDI (Keyboard)	15 inch color LCD (ABCD Type) [19 inch color LCD (QWERTY Full keyboard)]
Stored stroke check	Over travel
Operation	
Automatic operation	
MDI operation	
Program restart	
Program check function	Dry run / Program check / Machine lock
Single block	
Block search	Block search
Reposition	
Working area limit	Setting working area
Interpolation functions	
Positioning	G00
Linear interpolation	G01 G02, G03
Circular interpolation	Circular interpolation CW (G02) Circular interpolation CCW (G03) Non Modal : G09
Exact position stop	Modal : G60 (G601, G602, G603)
Dwell	G04
Reference position return	1st reference point : G75 X0 ... FP=1 2nd reference point : G75 X0 ... FP=2
Helical interpolation	
Thread synchronous cutting	
Thread cutting retract	
Spline interpolation	Non-uniform rational B splines
Feed function / Acc. & Dec. control	
Manual feed	Rapid traverse Jog Manual handle : x1, x10, x100 pulses Reference position return
Cutting Feed command	Direct input F code
Feedrate override	0 ~ 120%
Rapid traverse override	1%, 25%, 50%, 100%
Feed per minute	G94
Feed per revolution	G95
Look-ahead block	1 block
Program input	
ISO support	G291 (ISO)/G290 (ISO G Code system-A)
Optional block skip	8 ea (0~7)
Program stop / end	M00, M01 / M02, M30
Maximum command unit	± 999,999,999 mm, ± 99,999,9999 inch
Plane selection	X-Y : G17, X-Z : G18, Y-Z : G19 G54~G57, G505~G599
Workpiece coordinate system	G500 (Basic frame - Setable zero offset) G53 (Work offset non modal) G153 (Basic frame non modal)
Sub program call	16 folds nested
G code preventing buffering	STOPRE
Turning Cycle	with programing support
User Cycle	

Auxiliary function / Spindle speed function	
Auxiliary function	M Code 4 digit
Spindle speed function	S Code 5 digit
Spindle override	50% ~ 120%
Spindle orientation	SPOS
Rigid tapping	
Automatic mode interchange	Spindle / Axis mode
Constant surface speed control	G96, G97
Spindle speed limitation	LIMS
Tool function / Tool compensation	
Tool function	Tool number & Tool name Tool : T + Offset : D
Tool life management	
Tools in tool list	600 ea
Cutting Edges in tool list	1,500 ea
Tool nose radius compensation	ISO (G40, G41, G42)
Geometry / Wear compensation	
Measurement of tool length	
Tool management function	
Editing function	
Part program storage size	10MB
No. of registerable programs	1,000 ea
External Storage devices	USB
Background editing	
Extended part program editing	Copy, move and change of PLC program
Memory card program edit	
Data input / output & Interface	
I/O interface	USB memory interface Embedded Ethernet interface
Screenshot	
Setting, display and diagnosis	
Self-diagnosis function	
History display & Operation	Alarm & Operator message & Operation
Run hour / Parts count display	
Maintenance information	
Actual cutting feedrate display	
Display of spindle speed / T code	
Graphic display	
Operating monitor screen	Spindle / Servo load etc. Support 7 languages Chinese, English, French, German, Italian, Korean, Spanish [☆ Support 20 languages : Inquiry need]
Multi language display	
LCD Screen Saver	Screen saver & Motion sensing
Function	
Cs contour control (C & A axis)	
Polar coordinate interpolation	
Cylindrical interpolation	
Canned cycle for drilling	
Spindle synchronous control	
Servo Tailstock Function	
Polygon turning (CP-Basic)	
Balance cutting	
Option	
Contour handwheel	
3D simulation	
Simultaneous recording	Real time simulation of current machining operation
Additional axis control	
Shop Turn	Machining step programming for turning
Hobbing / Skiving (CP-Comfort)	

GLOBAL NETWORK



HEADQUARTER



R&D Center/Factory
153, Jeongdong-ro, Seongsan-gu,
Changwon-si, Gyeongsangnam-do, Korea
TEL : +82 55 280 9114



Overseas Sales Team /R&D Center
37, Cheoldobangmulgwan-ro, Uliwang-si,
Gyeonggi-do, Korea
TEL : +82 31 8090 2539

EUROPE



HYUNDAI WIA Machine Tools Europe
Alexander-Fleming-Ring 57, DE-65428
Russelsheim am Main, Germany
TEL : +49-0-6142-9256-0

AMERICA



HYUNDAI WIA Machine Tools America
450 Commerce Blvd, Carlstadt, NJ 07072, USA
TEL : +1-201-987-7298

ASIA



HYUNDAI WIA Machine Tools China
Company No.16 Fenghuang Road, Fenghuang
Town, Zhangjiagang City, Jiangsu Province, China
TEL : +86-512-5637-9719



Shanghai Branch Office (China)
3F-04, MT1, MixC Park, No.229, Haowen Road,
Minhang District, Shanghai, China
TEL : +86-21-6427-9885



Chengdu Branch Office (China)
Room 409B, Building 1, No.333, Yizhou Road,
High-Tech District, Chengdu, China
TEL : +86-21-5952-3256



Qingdao Branch Office (China)
Room 702, Yulong International Center, Building
1, No. 178-2, Haier Road, Laoshan District,
Qingdao, China. C.P. 266035
TEL : +86-28-8666-2985



CIS Branch Office
050051, Kazakhstan, Almaty, Elebekova street 10,
B.3, Office no.103
TEL : +7-(727)-355-7133



India Branch Office
#4/169, 1st Floor, LOTTE BLDG, Rajiv Gandhi
Salai, (OMR), Kandanchavadi, Chennai -600 096,
Tamilnadu, India
TEL : +91-76049-01618



LM1800TTSY
Movie



LM1800TTSY
3D Movie



You Tube HYUNDAI WIA MT
www.youtube.com/HYUNDAIWIAMT

CREATING VALUE IN SEAMLESS MOBILITY

With its top-quality HYUNDAI WIA machine tool creates a new and better world.



<http://machine.hyundai-wia.com>
HYUNDAI WIA Machine Tools
Global Links

2024-02 002.014 ENG