

600L/700L Series

L600LA/LMA | L700LA/LMA

HYUNDAI WIA Heavy Duty CNC Turning Center

Technical Leader

The CNC Turning Center L600L/700L Series designed by Hyundai WIA with years of expertise and the latest technology, is a Turning Center that maximizes productivity and performance.

| | | L600LA/LMA | L700LA/LMA |
|----------------------|--------|--|-------------------------------|
| Max. Turning Dia. | mm(in) | Ø920 (36.2") | |
| Max. Turning Length | mm(in) | 3,250 (128") | |
| Chuck Size | inch | [18" / 21" / 24"] | [24" / 32"] |
| Bar Capacity | mm(in) | [18"] : Ø117 (Ø4.6") / [21", 24"] : Ø139 (Ø5.5") | Ø165 (6.5") |
| Spindle Speed (rpm) | r/min | [18"] : 1,800 / [21"] : 1,700 / [24"] : 1,400 | [24"] : 1,500 / [32"] : 1,200 |
| Motor (30min./Cont.) | kW(HP) | 45/37 (60/50) | |
| Travel (X/Z) | mm(in) | 500/3,280 (19.7"/129.1") | |
| No. of Tools | EA | 12/12 (BMT85) | |

[] : Option

600L/700L Series

Heavy-Duty Cutting, Large Work Capacity, CNC Turning Center

- Sturdiness secured through box guideways on all axis
- One piece structure for high accuracy and rigidity
- Pretensioned double anchored method provides high precision
- 3 step gear box type main spindle
- Structure designed for machining long shafts and pipes with maximum turning length of 3,250mm (128")



01 BASIC STRUCTURE

High Rigid Bed & Structure for Heavy Duty Cutting CNC Turning Center

High Precision Spindle

- L600L Series : 1,800 r/min
- L700L Series : 1,500 r/min
- C-Axis Control : 0.001° ('M' Type)

Servo Turret

- No. of Tools : 12 EA
- Tool Size (O.D./I.D.)
 - 32/Ø80 (Ø1 1/4"/Ø3")
- BMT85 : 3,000 rpm ('M' Type)

Spindle Gear Box

- 3 Step

Built-in Tail Stock

- Taper : MT#6
- Quill Travel : 132.5 mm (5.2")

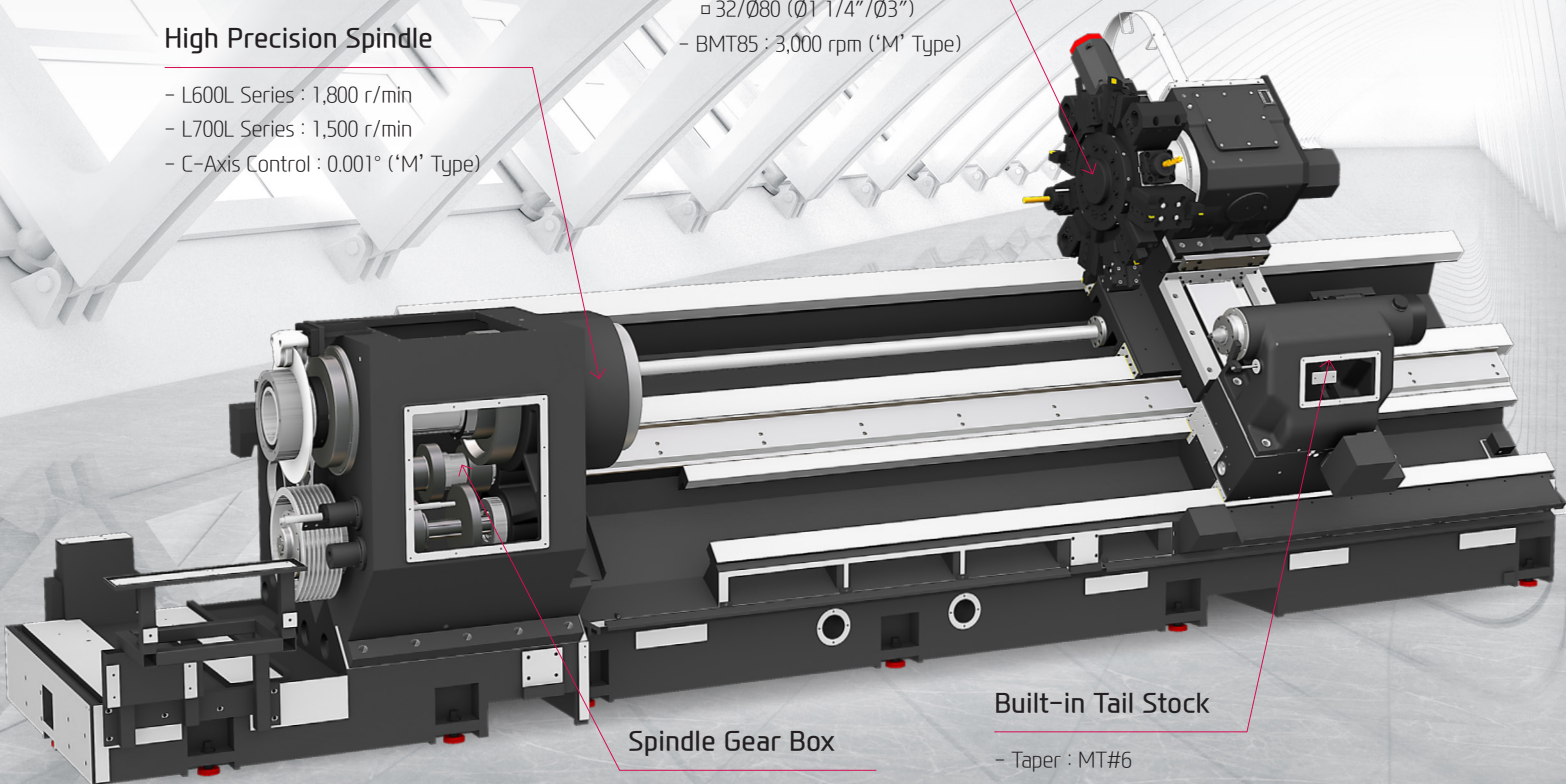

02 HIGH PRECISION SPINDLE

Long Lasting, High Accuracy & Excellent Performance CTE Turning Center

Spindle Specifications

[] : Option

| MODEL | Spindle Speed | Motor (Max./Cont.) | Torque (Max./Cont.) | Driving Method |
|--------------|----------------------|-----------------------|--|--------------------------|
| L600L Series | 1,800 rpm | 45/37 kW (60/50 HP) | 5,610/4,621 N·m (4,137.7/3,408.3 lbf·ft) | Belt + 3 Step Gear |
| | 1,500 rpm | 45/37 kW (60/50 HP) | 6,928/5,700 N·m (5,109.8/4,204.1 lbf·ft) | |
| L700L Series | [1,200 rpm] | [45/37 kW (60/50 HP)] | [6,928/5,700 N·m (5,109.8/4,204.1 lbf·ft)] | |
| | [Big Bore : 700 rpm] | [45/37 kW (60/50 HP)] | [7,045/5,795 N·m (5,196.1/4,274.2 lbf·ft)] | |

HEAVY DUTY CUTTING & HIGH ACCURACY

MAIN SPINDLE

Spindle Ideal for Heavy Cutting

To accomplish advanced stability during heavy duty cutting, a combination of P4 double cylindrical roller bearings and angular bearings are adopted. The double locking device separates the spindle bearing and pulley to prevent a decrease in spindle bearing pretension during interrupted cutting, heavy duty cutting, chuck cylinder operations, and by belt pulley tension.

3 Step Spindle Gear Box

Gear shift of spindle provide stability and high torque during low speed.

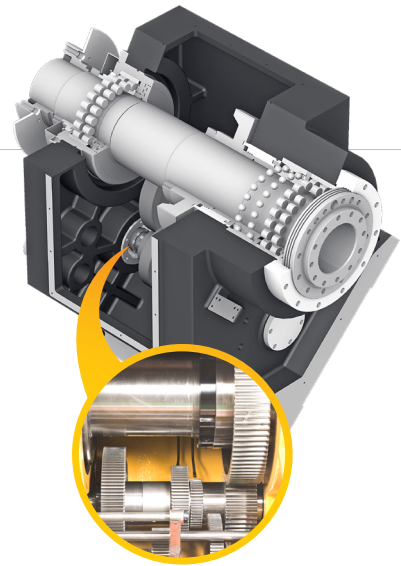

C-Axis Control ('M' Type)

The C-axis is capable of 0.001° control when milling turret is applied. Machining capability is strengthened with turning and milling operations.

※ Prior consultation is required when applying spindle contouring control for gear driven spindle.

BIG BORE SPINDLE

Max. Spindle Bore $\varnothing 320$ ($\varnothing 12.6''$) show excellent performance in machining large cylindrical parts for oil and gas industry.

Air Chucking System **OPTION**

A dual chuck design – one on each end of the spindle – offers superior support of the workpiece such as long shafts or pipe.

Spindle Bore **Big Bore : $\varnothing 320$ mm ($\varnothing 12.6''$)**

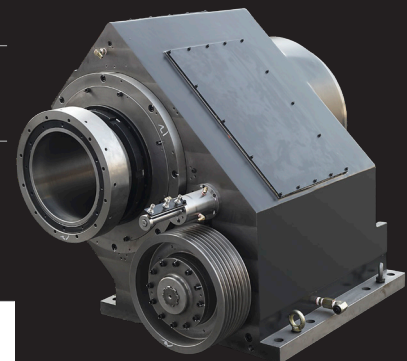

03 SERVO TURRET

High speed, High Accuracy, Highly Reliable Servo Turret

Servo Turret

No. of Tools

12_{EA}

Tool Size (O.D./i.D)

□ 32/Ø80 mm (Ø1 1/4"/Ø3")

Indexing Time

0.4_{sec}

Mill Turret

| ITEM | Speed | Motor (Max./Cont) | Torque (Max./Cont) | Collet Size |
|-------|-----------|---------------------|----------------------------------|-------------------|
| BMT85 | 3,000 rpm | 11/7.5 kW (15/10HP) | 140/95.4 N·m (103.3/70.4 lbf·ft) | ER50 / Ø34 (1.3") |

VARIOUS DRIVEN PRECISION BMT TOOL HOLDERS

SERVO TURRET



Standard Turret

The L600LA/700LA apply an AC Servo Motor to enhance machining reliability. Also, split accuracy is improved by using 3-piece couplings. Powerful hydraulic tool clamping system minimizes tool tip displacement caused by workload.

70 bar High Pressure Coolant **OPTION**

Turret is designed to utilize 70 bar high pressure coolant and it shows optimum performance in machining difficult-to-cut material.

BMT85 Turret ('M' Type)

The BMT turret secures the tool with four bolts and key on the tool mounting surface of the turret, making it possible to powerfully fix the tool, ensuring high reliability in rigidity and precision.

STRAIGHT MILLING HEAD



ANGULAR MILLING HEAD



Mill Tool Holder

Machining capability has increased with the addition of straight milling head tool holder.

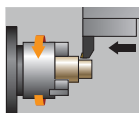
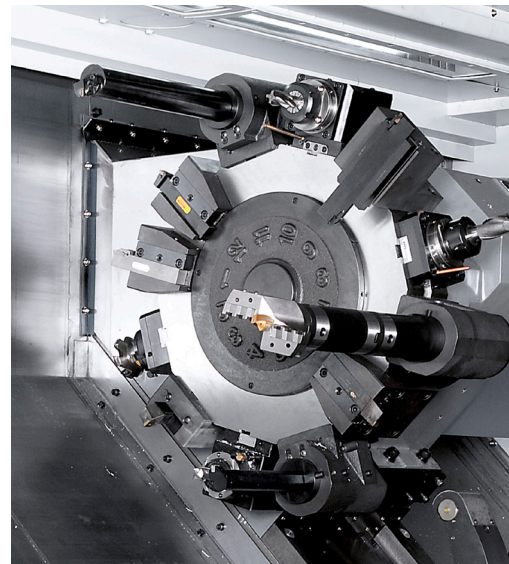

Heavy-duty cutting (O.D)
(Material : S45C)

| | |
|----------------|--------------|
| Spindle rpm | 96 r/min |
| Cutting speed | 150 m/min |
| Cutting depth | 12 mm |
| Forwarding | 0.65 mm/rev |
| Chip discharge | 1,170 cc/min |

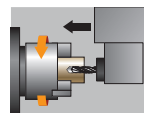

U-Drilling
(Material : S45C)

| | |
|----------------|-------------|
| Tool diameter | Ø180 |
| Cutting speed | 130 m/min |
| Cutting depth | 50 mm |
| Forwarding | 0.14 mm/rev |
| Chip discharge | 814 cc/min |

❖ The above result might be different by types of processing circumstance.

04 USER CONVENIENCE

Various Devices for User Friendly

TAIL STOCK

Built-In Tail Stock

The built-in tail stock ensures high accuracy even during heavy duty cutting and can be controlled automatically or manually.

| Taper | Quill Dia. | Quill Travel |
|-------|----------------|-----------------|
| MT#6 | Ø160 mm (6.3") | 132.5 mm (5.2") |

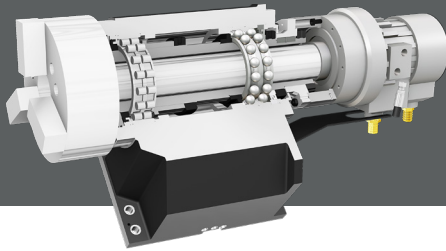

Chuck Type Tail Stock **OPTION**

When machining material like pipe stable product-machining is possible with the use of chuck type tail stock.

| | | |
|------------------|-----------------------|-----------------------------|
| Chuck Size : 12" | Sp. Speed : 3,000 rpm | Quill Dia. : Ø95 mm (Ø3.7") |
|------------------|-----------------------|-----------------------------|

MACHINING SUPPORT SYSTEM



Automatic Q-Setter

Cutting tools are calibrated quickly and accurately with the addition of a q-setter. Each tool tip is touched off manually using a sensor that inputs the position automatically.

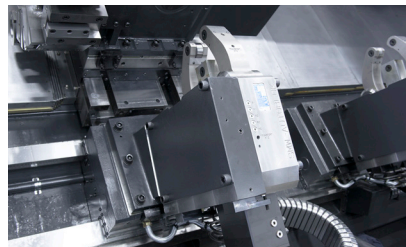

Steady Rest **OPTION**

For long parts, such as shafts, the steady rest increases rigidity and minimizes vibration. (Manual/Programmable hydraulic steady rest)



Rear Chuck **OPTION**

The rear chuck option enables long products such as long shaft or pipes to be processed in a stable condition.

Optional

COOLANT UNIT



Standard Coolant (Nozzle)

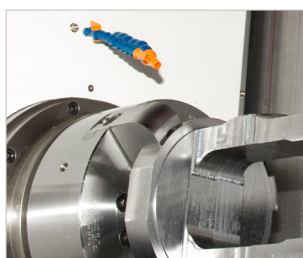

Chuck Coolant (Upper Chuck)

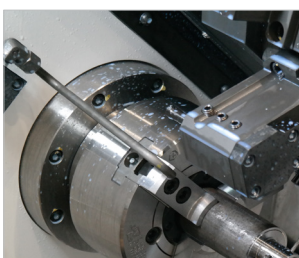

Chuck Air Blow (Upper Chuck)



Gun Coolant

CHIP DISPOSAL SOLUTION

Chip Conveyor

Timely and effective disposal of chips will enhance productivity as well as the working environment.

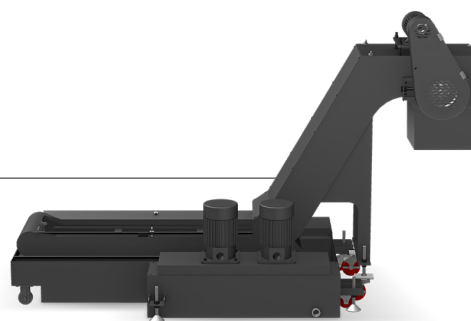

| | | | |
|---------------|---|----------------------------------|--------------------------|
| Hinge | Chip Type : Roughing Chip, Long Chip, Chip complex | Material : SS41, 45C, Cast Steel | Front-Right Direction |
| | Highly efficient when disposing a lot of chips. Capable of handling stringy chips.. | | |
| Scraper | Chip Type : Finely broken chip blown out | Material : cast Iron, Nonferrous | |
| | Convenient for shortly cut chips. | | |
| ❖ Drum Filter | Chip Type : Powder, Micro Chip | Material : AL | |
| | Advantageous in precision, as the chips do not flow in to the coolant nozzle. | | |

❖ When ordering a drum filter chip conveyor, prior consult with hyundai wia's sales person.

SPECIFICATIONS

Standard & Optional

● : Standard ○ : Option ☆ : Prior Consultation - : Non Applicable

| Spindle | | L600LA | L600LMA |
|--|--------------------------------|-------------------|---------|
| No Chuck | | ● | ● |
| Main Spindle Hollow Chuck 3 Jaw | 18" | ○ | ○ |
| | 21" | ○ | ○ |
| | 24" | ○ | ○ |
| Main Spindle Solid Chuck 3 Jaw | 18" | - | - |
| | 21" | - | - |
| | 24" | - | - |
| Standard Soft Jaw (1set) | | ○ | ○ |
| Chuck Clamp Foot Switch | | ● | ● |
| 2 Steps Hyd. Pressure Device | | ○ | ○ |
| Spindle Inside Stopper | | ☆ | ☆ |
| 5" Index | | ☆ | ☆ |
| Cs-Axis (0.001") | | - | - |
| Chuck Open/Close Confirmation Device | | ● | ● |
| 2 Steps Chuck Foot Switch | | ○ | ○ |
| Turret | | | |
| Tool Holder | | ● | ● |
| Mill Turret | BMT | - | ● |
| | Adaptor Type | - | ● |
| Angular Milling Head | Adaptor Type | - | ● |
| | | | |
| Boring Sleeve | | ● | ● |
| Drill Socket | | ○ | ○ |
| U-Drill Cap | | ● | ● |
| Long Boring Bar I.D Holder | | ☆ | ☆ |
| Angle Head | | - | ☆ |
| Tail Stock & Steady Rest | | | |
| Built-In Tail Stock | | ● | ● |
| Programmable Tail Stock | | ● | ● |
| Manual Type Steady Rest | | ☆ | ☆ |
| Manual Type Hyd. Steady Rest | | - | - |
| Programmable Hyd. Steady Rest | | ○ | ○ |
| Fixed center | | ● | ● |
| 2 Steps Tail Stock Pressure System | | ☆ | ☆ |
| Quill Forward/Reverse Confirmation Device | | ○(CE:●) | ○(CE:●) |
| Tail Stock Foot Switch (Standard when selecting the tailstock / Excluding the motor tailstock) | | ● | ● |
| Coolant & Air Blow | | | |
| Standard Coolant (Nozzle) | | ● | ● |
| Bed Flushing Coolant | | ● | ● |
| Chuck Coolant (Upper Chuck) | | ○ | ○ |
| Gun Coolant | | ○ | ○ |
| Spindle Thru Coolant (Only for Special Chuck) | | ☆ | ☆ |
| Thru Coolant for Live Tool | | - | - |
| Chuck Air Blow (Upper Chuck) | | ○ | ○ |
| Tail Stock Air Blow (Upper Tail Stock) | | ☆ | ☆ |
| Turret Air Blow | | ☆ | ☆ |
| Air Gun | | ○ | ○ |
| Spindle Thru Air Blow (Only for Special Chuck) | | ☆ | ☆ |
| High Pressure Coolant | 6Bar | ● | ● |
| | 20Bar | ○ | ○ |
| | 70Bar | ○ | ○ |
| Power Coolant System (For Automation) | | ☆ | ☆ |
| Coolant Chiller | | ☆ | ☆ |
| Chip Disposal | | | |
| Coolant Tank | | 770 ℓ (203.4 gal) | ● |
| Chip Conveyor (Hinge/Scraper) | Front (Right) | ○ | ○ |
| | Front (Rear) | - | - |
| Special Chip Conveyor (Drum Filter) | | ☆ | ☆ |
| Chip Wagon | Standard (180 ℓ [47.5 gal]) | ○ | ○ |
| | Swing (200 ℓ [52.8 gal]) | ○ | ○ |
| | Large Swing (290 ℓ [76.6 gal]) | ○ | ○ |
| | Large Size (330 ℓ [87.2 gal]) | ○ | ○ |
| | Customized | ☆ | ☆ |

| Safety Device | | L600LA | L600LMA |
|---|-----------------------|----------------|----------------|
| Total Splash Guard | | ● | ● |
| Chuck hydraulic pressure maintenance interlock | | ○(CE:●) | ○(CE:●) |
| Electric Device | | | |
| Call Light | 1Color : ● | ● | ● |
| Call Light & Buzzer | 3Color : ● ■ ■ B | ○ | ○ |
| Electric Cabinet Light | | ○ | ○ |
| Remote MPG | | ○ | ○ |
| Work Counter | Digital | ○ | ○ |
| Total Counter | | ○ | ○ |
| Tool Counter | | ○ | ○ |
| Multi Tool Counter | | ○ | ○ |
| Electric Circuit Breaker | | ○ | ○ |
| AVR (Auto Voltage Regulator) | | ☆ | ☆ |
| Transformer | 70kVA | ○ | ○ |
| Auto Power Off | | ○ | ○ |
| Measurement | | | |
| Q-Setter | | - | - |
| Automatic Q-Setter | | ● | ● |
| Work Close Confirmation Device (Only for Special Chuck) | TACO | ☆ | ☆ |
| | SMC | ☆ | ☆ |
| Work Setter | | ○ | ○ |
| Linear Scale | X Axis | ○ | ○ |
| | Z Axis | ○ | ○ |
| Coolant Level Sensor (Only for Chip Conveyor) | | ☆ | ☆ |
| Environment | | | |
| Air Conditioner | | ○ | ○ |
| Oil Mist Collector | | ☆ | ☆ |
| Oil Skimmer | | ○ | ○ |
| MQL (Minimal Quantity Lubrication) | | ☆ | ☆ |
| Fixture & Automation | | | |
| Auto Door | Standard | ○ | ○ |
| | High Speed | ☆ | ☆ |
| Auto Shutter (Only for Automatic System) | | - | - |
| Sub Operation Panel | | ☆ | ☆ |
| Bar Feeder Interface | | ○ | ○ |
| Bar Feeder | | ☆ | ☆ |
| Extra M-Code 4ea | | ○ | ○ |
| Automation Interface | | ☆ | ☆ |
| I/O Extension (IN & OUT) | 16 Contact | ○ | ○ |
| | 32 Contact | ○ | ○ |
| Parts Catcher | Main SP. | - | - |
| Turret Work Pusher (For Automation) | | ☆ | ☆ |
| Hyd. Device | | | |
| Standard Hyd. Cylinder | Hollow | ● | ● |
| Standard Hyd. Unit | 58bar/63 ℓ (16.6 gal) | ● | ● |
| S/W | | | |
| Dialogue Program (HW-DPRO) | | ○ | ○ |
| DNC software (HW-eDNC) | | ○ | ○ |
| Machine Monitoring System (HW-MMS Cloud) | | ☆ | ☆ |
| Smart Guide-i : FANUC | | ● (F32i-B : ☆) | ● (F32i-B : ☆) |
| Smart S/W | | ☆ | ☆ |
| ETC | | | |
| Tool Box | | ● | ● |
| Customized Color | Need Munsell No. | ☆ | ☆ |
| CAD & CAM | | ☆ | ☆ |

❖ 4 channel of TDC(Thermal Displacement Compensation) device is recommended, when more than 6 bar of high pressure coolant is applied, for the high quality machining. Specifications are subject to change without notice for improvement. / Please refer to the S/W catalog (iRIS) for details by S/W product.

SPECIFICATIONS

Standard & Optional

● : Standard ○ : Option ☆ : Prior Consultation - : Non Applicable

| Spindle | | L700LA | L700LMA |
|--|--------------------------------|---------|---------|
| No Chuck | | ● | ● |
| Main Spindle Hollow Chuck 3 Jaw | 18" | - | - |
| | 21" | - | - |
| | 24" | ○ | ○ |
| | 32" | ○ | ○ |
| Main Spindle Solid Chuck 3 Jaw | 18" | - | - |
| | 21" | - | - |
| | 24" | - | - |
| | 32" | - | - |
| Standard Soft Jaw (1set) | ○ | ○ | |
| Chuck Clamp Foot Switch | ● | ● | |
| 2 Steps Hyd. Pressure Device | ○ | ○ | |
| Spindle Inside Stopper | ☆ | ☆ | |
| 5" Index | ☆ | ☆ | |
| Cs-Axis (0.001") | - | ● | |
| Chuck Open/Close Confirmation Device | ● | ● | |
| 2 Steps Chuck Foot Switch | ○ | ○ | |
| Turret | | | |
| Tool Holder | | ● | ● |
| Mill Turret | BMT | - | ● |
| Straight Milling Head | Adaptor Type | - | ● |
| Angular Milling Head | Adaptor Type | - | ● |
| Boring Sleeve | | ● | ● |
| Drill Socket | | ○ | ○ |
| U-Drill Cap | | ● | ● |
| Long Boring Bar I.D Holder | | ☆ | ☆ |
| Angle Head | | - | ☆ |
| Tail Stock & Steady Rest | | | |
| Built-In Tail Stock | | ● | ● |
| Programmable Tail Stock | | ● | ● |
| Manual Type Steady Rest | | ☆ | ☆ |
| Manual Type Hyd. Steady Rest | | - | - |
| Programmable Hyd. Steady Rest | | ○ | ○ |
| Fixed center | | ● | ● |
| 2 Steps Tail Stock Pressure System | | ☆ | ☆ |
| Quill Forward/Reverse Confirmation Device | | ○(CE:●) | ○(CE:●) |
| Tail Stock Foot Switch (Standard when selecting the tailstock / Excluding the motor tailstock) | | ● | ● |
| Coolant & Air Blow | | | |
| Standard Coolant (Nozzle) | | ● | ● |
| Bed Flushing Coolant | | ● | ● |
| Chuck Coolant (Upper Chuck) | | ○ | ○ |
| Gun Coolant | | ○ | ○ |
| Spindle Thru Coolant (Only for Special Chuck) | | ☆ | ☆ |
| Thru Coolant for Live Tool | | - | - |
| Chuck Air Blow (Upper Chuck) | | ○ | ○ |
| Tail Stock Air Blow (Upper Tail Stock) | | ☆ | ☆ |
| Turret Air Blow | | ☆ | ☆ |
| Air Gun | | ○ | ○ |
| Spindle Thru Air Blow (Only for Special Chuck) | | ☆ | ☆ |
| High Pressure Coolant | 6Bar | ● | ● |
| | 20Bar | ○ | ○ |
| | 70Bar | ○ | ○ |
| Power Coolant System (For Automation) | | ☆ | ☆ |
| Coolant Chiller | | ☆ | ☆ |
| Chip Disposal | | | |
| Coolant Tank | 770 ℓ (203.4 gal) | ● | ● |
| Chip Conveyor (Hinge/Scraper) | Front (Right) | ○ | ○ |
| | Front (Rear) | - | - |
| Special Chip Conveyor (Drum Filter) | | ☆ | ☆ |
| Chip Wagon | Standard (180 ℓ [47.5 gal]) | ○ | ○ |
| | Swing (200 ℓ [52.8 gal]) | ○ | ○ |
| | Large Swing (290 ℓ [76.6 gal]) | ○ | ○ |
| | Large Size (330 ℓ [87.2 gal]) | ○ | ○ |
| | Customized | ☆ | ☆ |

| Safety Device | | L700LA | L700LMA |
|---|-----------------------|----------------|----------------|
| Total Splash Guard | | ● | ● |
| Chuck hydraulic pressure maintenance interlock | | ○(CE:●) | ○(CE:●) |
| Electric Device | | | |
| Call Light | 1Color : ● | ● | ● |
| Call Light & Buzzer | 3Color : ● ■ ■ B | ○ | ○ |
| Electric Cabinet Light | | ○ | ○ |
| Remote MPG | | ○ | ○ |
| Work Counter | Digital | ○ | ○ |
| Total Counter | Digital | ○ | ○ |
| Tool Counter | Digital | ○ | ○ |
| Multi Tool Counter | Digital | ○ | ○ |
| Electric Circuit Breaker | | ○ | ○ |
| AVR (Auto Voltage Regulator) | | ☆ | ☆ |
| Transformer | 70kVA | ○ | ○ |
| Auto Power Off | | ○ | ○ |
| Measurement | | | |
| Q-Setter | | - (Big Bore ○) | - (Big Bore ○) |
| Automatic Q-Setter | | ● (Big Bore -) | ● (Big Bore -) |
| Work Close Confirmation Device (Only for Special Chuck) | TACO | ☆ | ☆ |
| | SMC | ☆ | ☆ |
| Work Setter | | ○ | ○ |
| Linear Scale | X Axis | ○ | ○ |
| | Z Axis | ○ | ○ |
| Coolant Level Sensor (Only for Chip Conveyor) | | ☆ | ☆ |
| Environment | | | |
| Air Conditioner | | ○ | ○ |
| Oil Mist Collector | | ☆ | ☆ |
| Oil Skimmer | | ○ | ○ |
| MQL (Minimal Quantity Lubrication) | | ☆ | ☆ |
| Fixture & Automation | | | |
| Auto Door | Standard | ○ | ○ |
| | High Speed | ☆ | ☆ |
| Auto Shutter (Only for Automatic System) | | - | - |
| Sub Operation Pannel | | ☆ | ☆ |
| Bar Feeder Interface | | ○ | ○ |
| Bar Feeder | | ☆ | ☆ |
| Extra M-Code 4ea | | ○ | ○ |
| Automation Interface | | ☆ | ☆ |
| I/O Extension (IN & OUT) | 16 Contact | ○ | ○ |
| | 32 Contact | ○ | ○ |
| Parts Catcher | Main SP. | - | - |
| Turret Work Pusher (For Automation) | | ☆ | ☆ |
| Hyd. Device | | | |
| Standard Hyd. Cylinder | Hollow | ● | ● |
| Standard Hyd. Unit | 58bar/63 ℓ (16.6 gal) | ● | ● |
| S/W | | | |
| Dialogue Program (HW-DPRO) | | ○ | ○ |
| DNC software (HW-eDNC) | | ○ | ○ |
| Machine Monitoring System (HW-MMS Cloud) | | ☆ | ☆ |
| Smart Guide-i : FANUC | | ● (F32i-B : ☆) | ● (F32i-B : ☆) |
| Smart S/W | | ☆ | ☆ |
| ETC | | | |
| Tool Box | | ● | ● |
| Customized Color | Need Munsel No. | ☆ | ☆ |
| CAD & CAM | | ☆ | ☆ |

✦ 4 channel of TDC(Thermal Displacement Compensation) device is recommended, when more than 6 bar of high pressure coolant is applied, for the high quality machining.

Specifications are subject to change without notice for improvement. / Please refer to the S/W catalog (IRIS) for details by S/W product.

SPECIFICATIONS

Spindle Output/Torque Diagram

L600L Series 1,800 rpm

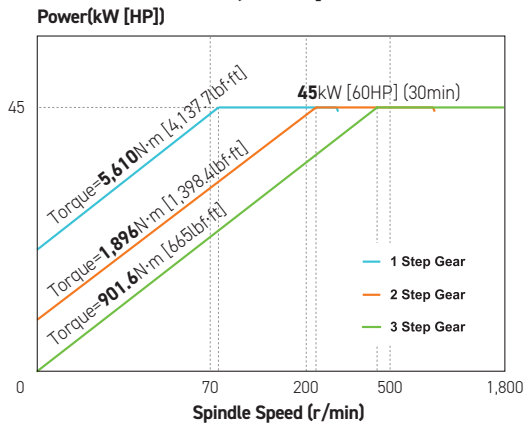

L700L Series 1,500 rpm

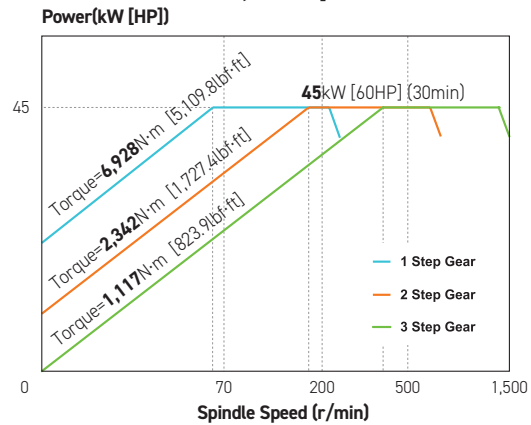

L700L Series (BIG BORE) 700 rpm

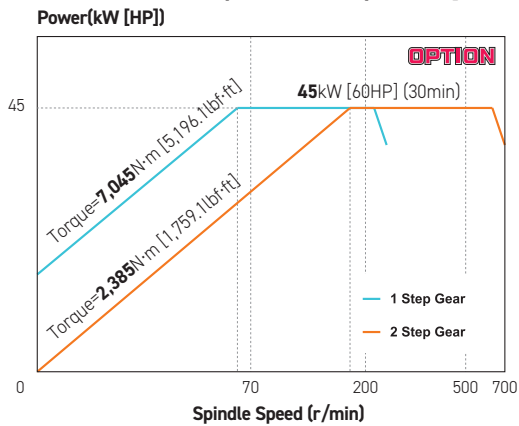

Mill Turret 3,000 rpm

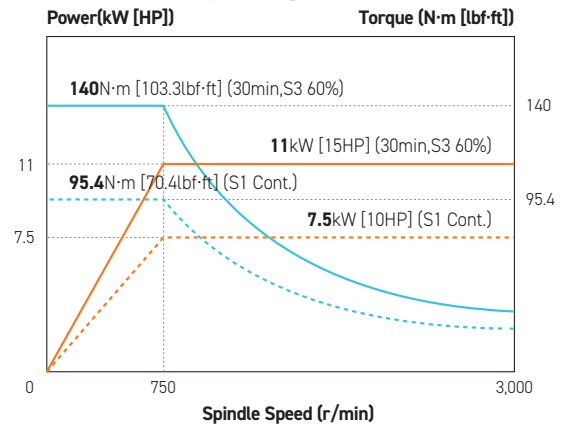

SPECIFICATIONS

External Dimensions

unit : mm(in)

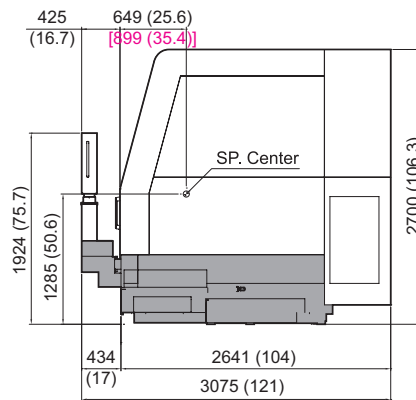
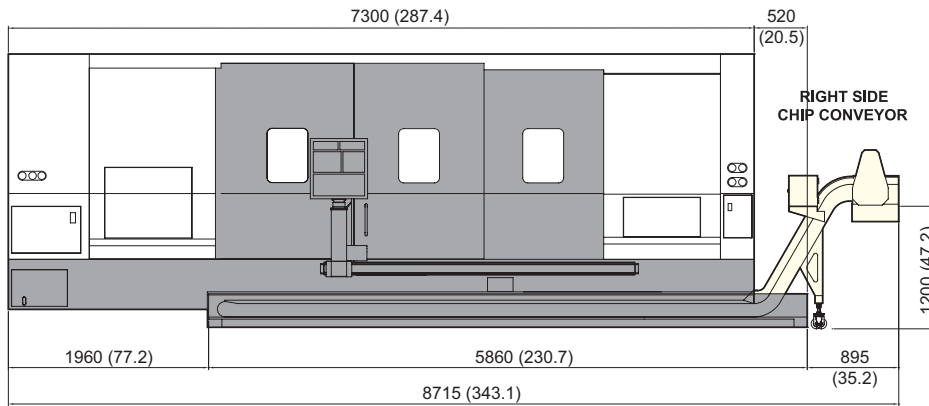
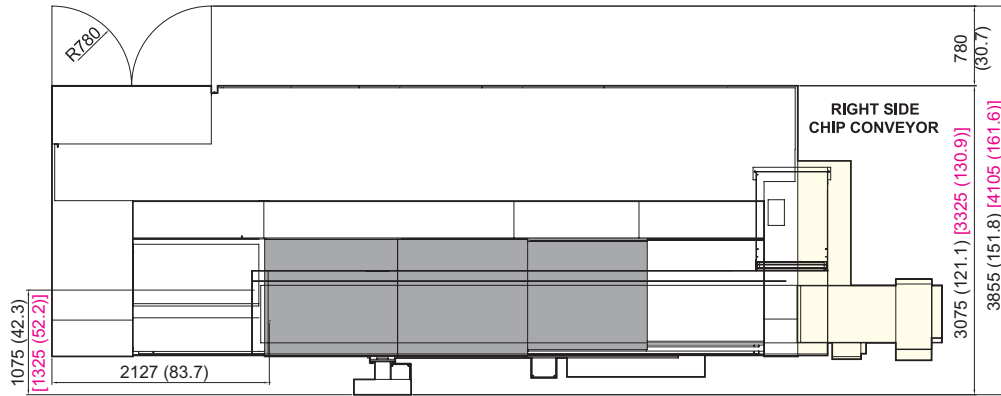

[When applying K6.1 steady rest device]

SPECIFICATIONS

Interference

unit : mm(in)

L600LA/700LA

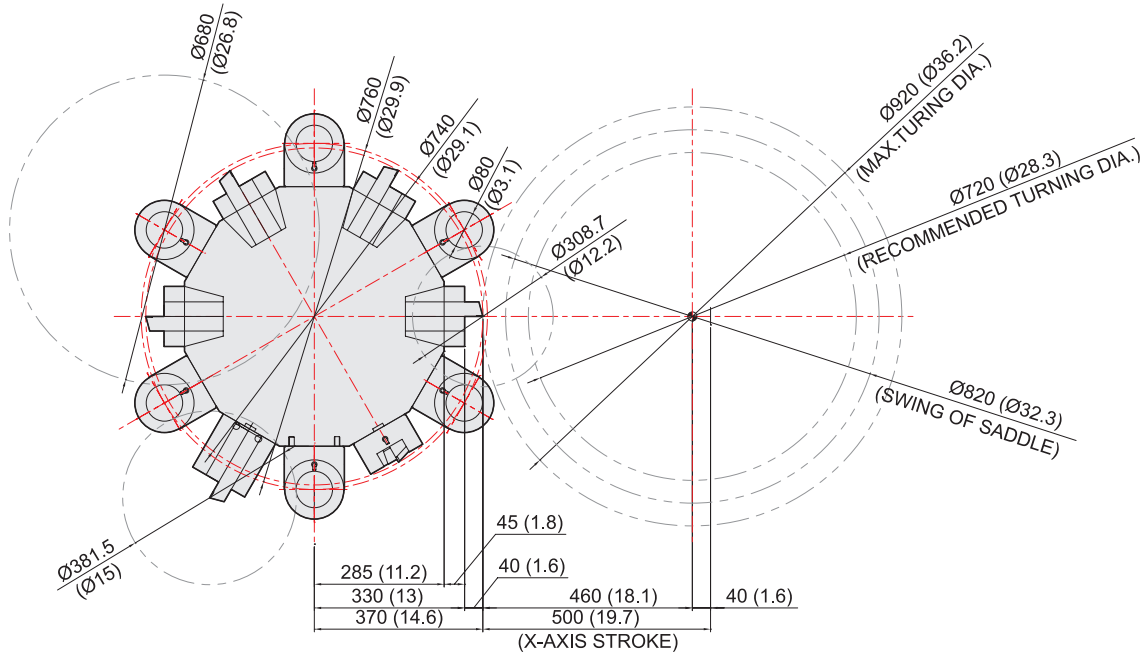

L600LMA/700LMA

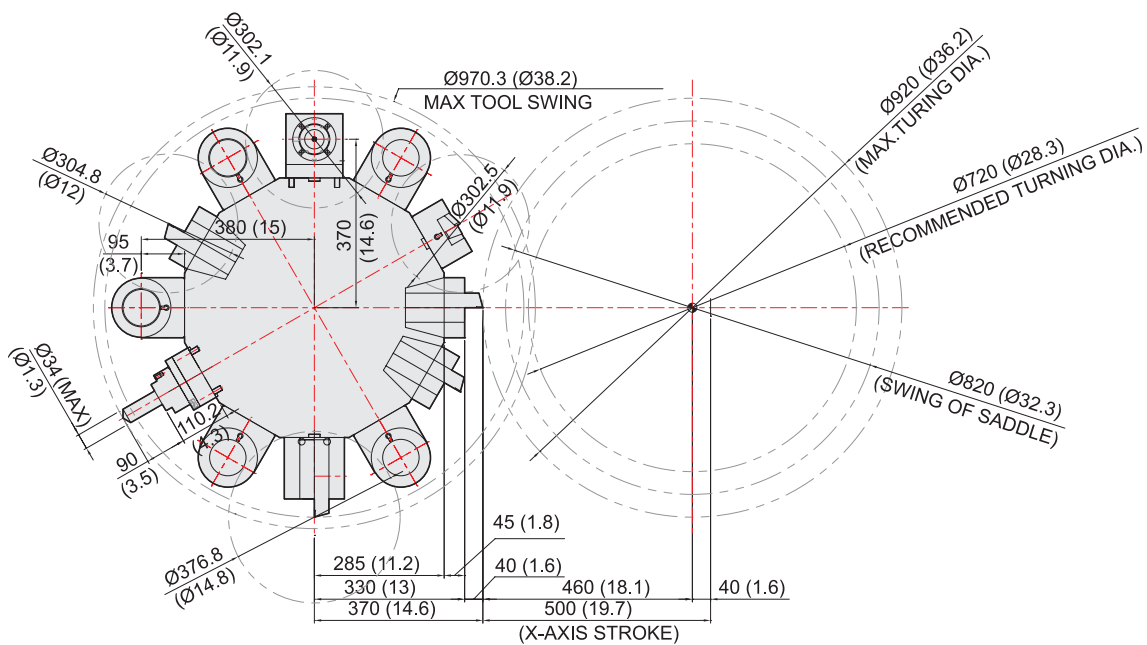

SPECIFICATIONS

Tooling System

unit : mm(in)

L600LA/700LA

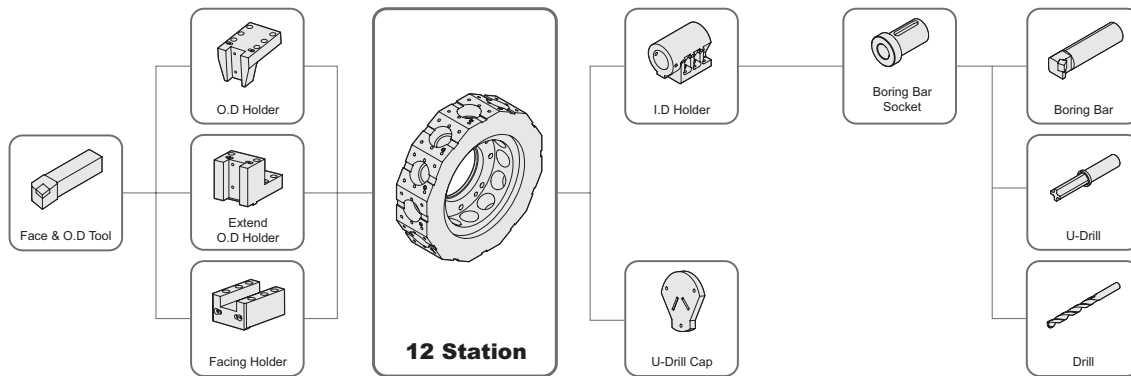

L600L/700L Series Tooling Parts Detail

| ITEM | | | L600LA/700LA | |
|----------------|----------------------|---------------|--------------|-----------|
| | | | mm Unit | inch Unit |
| Turning Holder | O.D Holder | Right/Left | 4 | 4 |
| | | Extended | 1 | 1 |
| | Facing Holder | 1 | 1 | |
| Boring Holder | I.D Holder | Single | 6 | 6 |
| | | Long (SET) | Opt | - |
| Driven Holder | Straight Mill Holder | Standard | - | - |
| | Angular Mill Holder | Standard | - | - |
| Socket | Boring | Ø20 (Ø3/4") | 1 | 1 |
| | | Ø25 (Ø1") | 1 | 1 |
| | | Ø32 (Ø1 1/4") | 1 | 1 |
| | | Ø40 (Ø1 1/2") | 1 | 1 |
| | | Ø50 (Ø2") | 1 | 1 |
| | | Ø60 (Ø2 1/4") | 1 | 1 |
| | Drill | MT 3 | Opt | Opt |
| | | MT 4 | Opt | Opt |
| | | MT 5 | Opt | Opt |
| | Adapter Set | | - | - |

Specifications are subject to change without notice for improvement.

SPECIFICATIONS

Tooling System

unit : mm(in)

L600LMA/700LMA

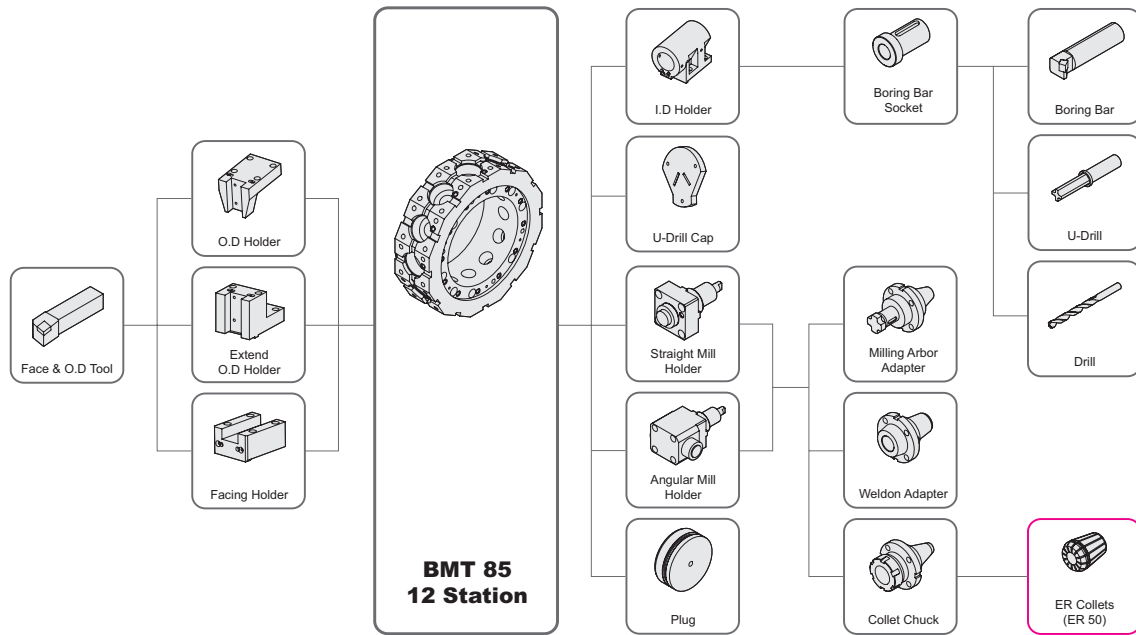

L600L/700L Series Tooling Parts Detail

| ITEM | | | L600LMA/700LMA | |
|----------------|----------------------|---------------|----------------|-----------|
| | | | mm Unit | inch Unit |
| Turning Holder | O.D Holder | Right/Left | 3 | 3 |
| | | Extended | 1 | 1 |
| | Facing Holder | 1 | 1 | |
| Boring Holder | I.D Holder | Single | 5 | 5 |
| | | Long (SET) | Opt | - |
| Driven Holder | Straight Mill Holder | Standard | 1 | 1 |
| | Angular Mill Holder | Standard | 1 | 1 |
| Socket | Boring | Ø20 (Ø3/4") | 1 | 1 |
| | | Ø25 (Ø1") | 1 | 1 |
| | | Ø32 (Ø1 1/4") | 1 | 1 |
| | | Ø40 (Ø1 1/2") | 1 | 1 |
| | | Ø50 (Ø2") | 1 | 1 |
| | | Ø60 (Ø2 1/4") | 1 | 1 |
| | Drill | MT 3 | Opt | Opt |
| | | MT 4 | Opt | Opt |
| | | MT 5 | Opt | Opt |
| | Adapter Set | | 1 Set | 1 Set |

SPECIFICATIONS

Specifications

[] : Option

| ITEM | | | L600LA | L600LMA | |
|---------------|---------------------------|-------------|---|-----------------------|--|
| CAPACITY | Swing Over the Bed | mm(in) | Ø1,050 (41.3") | | |
| | Swing Over the Carriage | mm(in) | Ø820 (32.3") | | |
| | Max. Turning Dia. | mm(in) | Ø920 (36.2") | | |
| | Max. Turning Length | mm(in) | 3,250 (128") | | |
| SPINDLE | Bar Capacity | mm(in) | [18"] : Ø117 (Ø4.6") / [21", 24"] : Ø139 (Ø5.5") | | |
| | Chuck Size | inch | Opt. [18" / 21" / 24"] | | |
| | Spindle Bore | mm(in) | Ø152 (6") | | |
| | Spindle Speed (rpm) | r/min | Opt. [18" : 1,800] [21" : 1,700] [24" : 1,400] | | |
| | Motor (30min./Cont.) | kW(HP) | [45/37 (60/50)] | | |
| | Torque (30min./Cont.) | N·m(lbf·ft) | [5,610/4,621 (4,137.7/3,408.3)] | | |
| | Spindle Type | - | BELT + 3 STEP GEAR | | |
| | Spindle Nose | - | A2-15 | | |
| FEED | C-axis Indexing | deg | - | 0.001° | |
| | Travel (X/Z) | mm(in) | 500/3,280 (19.7"/129.1") | | |
| | Rapid Traverse Rate (X/Z) | m/min | 12/12 | | |
| TURRET | Slide Type | - | BOX GUIDE | | |
| | No. of Tools | EA | 12 | | |
| | Tool Size | OD | mm(in) | ± 32 (1.3") | |
| | | ID | mm(in) | Ø80 (3.1") | |
| Indexing Time | sec/step | 0.4 | | | |
| LIVE TOOL | Motor (Max./Cont.) | kW(HP) | - | 11/7.5 (14.8/10) | |
| | Milling Tool Speed (rpm) | r/min | - | 3,000 | |
| | Torque (Max./Cont.) | N·m(lbf·ft) | - | 140/95.4 (103.3/70.4) | |
| | Collet Size | mm(in) | - | Ø34 (1.3") - ER50 | |
| | Type | - | - | BMT85 | |
| TAIL STOCK | Taper | - | MT6 (Built-in) | | |
| | Quill Dia. | mm(in) | Ø160 (6.3") | | |
| | Quill Travel | mm(in) | 132.5 (5.2") | | |
| | Travel | mm(in) | 3,180 (125.2") | | |
| TANK CAPACITY | Coolant Tank | ℓ (gal) | 770 (203.4) | | |
| | Lubricating Tank | ℓ (gal) | 4 (1.1) | | |
| POWER SUPPLY | Electric Power Supply | kVA | 50 | | |
| | Thickness of Power Cable | Sq | Over 50 | | |
| | Voltage | V/Hz | 220/60 (200/50*) | | |
| MACHINE | Floor Space (L×W) | mm(in) | 8,715×3,075 (343.1"×121.1") | | |
| | Height | mm(in) | 2,700 (106.3") | | |
| | Weight | kg(lb) | 23,500 (51,809) | | |
| PC | Controller | - | FANUC 32i-B [HYUNDAI WIA FANUC i Series - Smart Plus] | | |

*) Using 50Hz voltage instead of 60Hz may lower the output of motors. (excluding servo motors and inverter motors)

※ Prior consultation is required when applying spindle contouring control for gear driven spindle.

Specifications are subject to change without notice for improvement.

SPECIFICATIONS

Specifications

[] : Option

| ITEM | | L700LA | L700LMA | |
|---------------------------|---------------------------|-------------|---|--------------------------|
| CAPACITY | Swing Over the Bed | mm(in) | Ø1,050 (41.3") | |
| | Swing Over the Carriage | mm(in) | Ø820 (32.3") | |
| | Max. Turning Dia. | mm(in) | Ø920 (36.2") | |
| | Max. Turning Length | mm(in) | 3,250 (128") | |
| SPINDLE | Bar Capacity | mm(in) | Ø165 (6.5") | |
| | Chuck Size | inch | Opt. [24" / 32"] | |
| | Spindle Bore | mm(in) | Ø181 (7.1") | |
| | Spindle Speed (rpm) | r/min | [24"] : 1,500 / [32"] : 1,200 | |
| | Motor (30min./Cont.) | kW(HP) | 45/37 (60/50) | |
| | Torque (30min./Cont.) | N-m(lbf-ft) | 6,928/5,700 (5,109.8/4,204.1) | |
| | Spindle Type | - | BELT+3STEP GEAR | |
| | Spindle Nose | - | A1-15 | |
| C-axis Indexing | deg | - | 0.001° | |
| BIG BORE SPINDLE (Option) | Bar Capacity | mm(in) | [Hydraulic : Ø239 (9.4") / Air, Independent : Ø319 (12.6")] | |
| | Chuck Size | inch | [24" : Independent / 27" : Air / 32" : Hydraulic] | |
| | Spindle Bore | mm(in) | Ø320 (12.6") | |
| | Spindle Speed (rpm) | r/min | [700] | |
| | Motor (30min./Cont.) | kW(HP) | [45/37 (60/50)] | |
| | Torque (30min./Cont.) | N-m(lbf-ft) | [7,045/5,795 (5,196.1/4,274.2)] | |
| | Spindle Nose | - | [A1-20] | |
| FEED | Travel (X/Z) | mm(in) | 500/3,280 (19.7"/129.1") | |
| | Rapid Traverse Rate (X/Z) | m/min | 12/12 | |
| | Slide Type | - | BOX GUIDE | |
| TURRET | No. of Tools | EA | 12 | |
| | Tool Size | OD / ID | mm(in) | □ 32 (1.3") / Ø80 (3.1") |
| | Indexing Time | sec/step | 0.4 | |
| LIVE TOOL | Motor (Max/Cont.) | kW(HP) | - | 11/7.5 (14.8/10) |
| | Milling Tool Speed (rpm) | r/min | - | 3,000 |
| | Torque (Max/Cont.) | N-m(lbf-ft) | - | 140/95.4 (103.3/70.4) |
| | Collet Size | mm(in) | - | Ø34 (1.3") - ER50 |
| | Type | - | - | BMT85 |
| TAIL STOCK | Taper | - | MT6 (Built-in) | |
| | Quill Dia. | mm(in) | Ø160 (6.3") | |
| | Quill Travel | mm(in) | 132.5 (5.2") | |
| | Travel | mm(in) | 3,180 (125.2") | |
| TANK CAPACITY | Coolant Tank | ℓ (gal) | 770 (203.4) | |
| | Lubricating Tank | ℓ (gal) | 4 (1.1) | |
| POWER SUPPLY | Electric Power Supply | kVA | 51 | |
| | Thickness of Power Cable | Sq | Over 50 | |
| | Voltage | V/Hz | 220/60 (200/50*) | |
| MACHINE | Floor Space (L×W) | mm(in) | 8,715×3,075 (343.1"×121.1") | |
| | Height | mm(in) | 2,700 (106.3") | |
| | Weight | kg(lb) | 23,500 (51,809) | |
| NC | Controller | - | FANUC 32i-B [HYUNDAI WIA FANUC i Series - Smart Plus] | |

*) Using 50Hz voltage instead of 60Hz may lower the output of motors. (excluding servo motors and inverter motors)

※ Prior consultation is required when applying spindle contouring control for gear driven spindle.

Specifications are subject to change without notice for improvement.

CONTROLLER

FANUC 32i-B

[] : Option

| Controlled axis / Display / Accuracy Compensation | |
|---|--|
| Control axis | 2 axis (X, Z) / 3 axis (X, Z, C) / 4 axis (X, Z, Y, C) 5 axis (X, Z, B, C, A) / 6 axis (X, Z, Y, B, C, A) |
| Simultaneously controlled axis | 2 axis [Max. 4 axis] |
| Designation of spindle axis | 4 axis (1 path), 6 axis (2 path Total) |
| Least setting Unit | X, Z, Y, B axis : 0.001 mm (0.0001 inch) C, A axis : 0.001 deg |
| Least input increment | X, Z, Y, B axis : 0.001 mm (0.0001 inch) C, A axis : 0.001 deg |
| Inch / Metric conversion | G20 / G21 |
| High response vector control | |
| Interlock | All axis / Each axis |
| Machine lock | All axis |
| Backlash compensation | ± 0 ~ 9999 pulses (Rapid traverse / Cutting feed) |
| Position switch | |
| LCD / MDI | 10.4 inch color LCD |
| Feedback | Absolute motor feedback |
| Stored stroke check 1 | Over travel |
| Stored stroke check 2, 3 | |
| PMC axis control | |
| Operation | |
| Automatic operation (Memory) | |
| MDI operation | |
| DNC operation | Needed DNC software / CF card |
| Program restart | |
| Wrong operation prevention | |
| Program check function | Dry run, Program check |
| Single block | |
| Search function | Program Number / Sequence Number |
| Interpolation functions | |
| Nano interpolation | |
| Positioning | G00 |
| Linear interpolation | G01 |
| Circular interpolation | G02, G03 |
| Exact stop mode | Single : G09, Continuous : G61 |
| Dwell | G04, 0 ~ 9999.9999 sec |
| Skip | G31 |
| Reference position return | 1st reference : G28 2nd reference : G30 Ref. position check : G27 |
| Thread synchronous cutting | |
| Thread cutting retract | |
| Variable lead thread cutting | |
| Multi / Continuous threading | |
| Feed function / Acc. & Dec. control | |
| Manual feed | Rapid traverse Jog : 0~2,000 mm/min (79 ipm) Manual handle : x1, x10, x100 pulses Reference position return |
| Cutting Feed command | Direct input F code |
| Feedrate override | 0 ~ 200% (10% Unit) |
| Rapid traverse override | F1%, F25%, 50%, F100% |
| Override cancel | |
| Feed per minute | G98 |
| Feed per revolution | G99 |
| Look-ahead block | 1 block |
| Program input | |
| Tape Code | EIA / ISO |
| Optional block skip | 1 ea |
| Program stop / end | M00, M01 / M02, M30 |
| Maximum command unit | ± 999,999,999 mm (± 99,999,999 inch) |
| Plane selection | X-Y : G17 / Z-X : G18 / Y-Z : G19 |
| Workpiece coordinate system | G52, G53, 6 pairs (G54 ~ G59) |
| Manual absolute | Fixed ON |
| Programmable data input | G10 |
| Sub program call | 10 folds nested |
| Custom macro | #100 ~ #149, #500 ~ #549 |
| G code system | A |
| Programmable mirror image | G51.1, G50.1 |
| G code preventing buffering | G4.1 |
| Multiple repetitive cycles I, II | |
| Program input | |

| Canned cycle for turning | |
|---|--|
| Manual Guide i | Conversational auto program |
| Auxiliary function / Spindle speed function | |
| Auxiliary function | M 4 digit |
| Level-up M Code | High speed / Multi / Bypass M code |
| Spindle speed function | S 4 digit , Binary output |
| Spindle override | 0% ~ 150% (10% Unit) |
| Multi position spindle orientation | M19 |
| Rigid tapping | |
| Constant surface speed control | G96, G97 |
| Tool function / Tool compensation | |
| Tool function | T 2 digit + Offset 2 digit |
| Tool life management | |
| Tool offset pairs | 32 pairs |
| Tool nose radius compensation | G40, G41, G42 |
| Geometry / Wear compensation | |
| Direct input of offset measured B | |
| Editing function | |
| Part program storage size | 640m (256KB) |
| No. of registerable programs | 500 ea |
| Program protect | |
| Background editing | |
| Extended part program editing | Copy, move and change of NC program |
| Memory card program edit | |
| Data input / output & Interface | |
| I/O interface | CF card, USB memory Embedded Ethernet interface |
| Screen hard copy | |
| External message | |
| External key input | |
| External workpiece number search | |
| Automatic data backup | |
| Setting, display and diagnosis | |
| Self-diagnosis function | |
| History display & Operation | Alarm & Operator message & Operation |
| Run hour / Parts count display | |
| Maintenance information | |
| Actual cutting feedrate display | |
| Display of spindle speed / T code | |
| Graphic display | |
| Operating monitor screen | Spindle / Servo load etc. |
| Power consumption monitoring | Spindle & Servo |
| Spindle / Servo setting screen | |
| Multi language display | Support 20 languages |
| Display language switching | Selection of 5 optional Languages |
| LCD Screen Saver | Screen saver |
| Unexpected disturbance torque | BST (Back spin torque limit) |
| Function for machine type | |
| Cs contour control (C & A axis) | Mill, MS, Y, SY, LF-Mill, TTMS, TTSY |
| Polar coordinate interpolation | Mill, MS, Y, SY, LF-Mill, TTMS, TTSY |
| Cylindrical interpolation | Mill, MS, Y, SY, LF-Mill, TTMS, TTSY |
| Canned cycle for drilling | Mill, MS, Y, SY, LF-Mill, TTMS, TTSY |
| Spindle orientation expansion | MS, SY TTS, TTMS, TTSY |
| Spindle synchronous control | MS, SY TTS, TTMS, TTSY |
| Torque control | MS, SY TTS, TTMS, TTSY |
| Y axis offset | Y, SY, TTSY |
| Arbitrary angular control | Y, SY, TTSY |
| Composite / Superimposed control | MS, SY TTS, TTMS, TTSY |
| Balance cutting | MS, SY TTS, TTMS, TTSY |
| Option | |
| Additional optional block skip | 9 ea |
| Fast ethernet | Needed option board |
| Data server | Needed option board |
| Protection of data at 8 levels | |
| Tool offset pairs | 64 pairs / 99 pairs / 200 pairs |
| Part program storage size | 1280 m (512KB) / 2560m (1MB) |
| Polygon turning (2 Spindles) | Mill, MS, Y, SY, LF-Mill, TTMS, TTSY |
| Helical interpolation | |
| Dynamic graphic display | |
| Direct drawing dimension program | Including Chamfering / Corner R |

Figures in inch are converted from metric values.

The FANUC controller specifications are subject to change based on the policy of company CNC supplying.

CONTROLLER

HYUNDAI WIA FANUC i Series – Smart Plus

[] : Option

| Controlled axis / Display / Accuracy Compensation | |
|---|--|
| Control axis | 2 axis (X, Z) / 3 axis (X, Z, C) / 4 axis (X, Z, Y, C) 5 axis (X, Z, B, C, A) / 6 axis (X, Z, Y, B, C, A) 7 axis (X1/Z1, X2/Z2, B2, C1/C2) |
| Simultaneously controlled axis | 2 axis [Max. 4 axis] |
| Designation of spindle axis | 3 axis [Max. 4 axis] X, Z, Y, B axis : 0.001 mm (0.0001 inch) |
| Least setting Unit | C, A axis : 0.001 deg |
| Least input increment | X, Z, Y, B axis : 0.001 mm (0.0001 inch) C, A axis : 0.001 deg |
| Inch / Metric conversion | G20 / G21 |
| High response vector control | |
| Interlock | All axis / Each axis |
| Machine lock | All axis |
| Backlash compensation | ± 0~9999 pulses (exc. Rapid traverse / Cutting feed) |
| Position switch | |
| LCD / MDI | 15 inch LCD unit (with Touch Panel) |
| Feedback | Absolute motor feedback |
| Stored stroke check 1 | Over travel |
| Stored stroke check 2, 3 | |
| PMC axis control | |
| Operation | |
| Automatic operation (Memory) | |
| MDI operation | |
| DNC operation | Needed DNC software / CF card |
| Program restart | |
| Wrong operation prevention | |
| Program check function | Dry run |
| Single block | |
| Search function | Program Number / Sequence Number |
| Interpolation functions | |
| Pano interpolation | |
| Positioning | G00 |
| Linear interpolation | G01 |
| Circular interpolation | G02, G03 |
| Exact stop mode | Single : G09, Continuous : G61 |
| Dwell | G04, 0 ~ 9999.9999 sec |
| Skip | G31 |
| Reference position return | 1st reference : G28, 2nd reference : G30 Ref. position check : G27 |
| Thread synchronous cutting | G33 |
| Thread cutting retract | |
| Variable lead thread cutting | |
| Multi / Continuous threading | |
| Feed function / Acc. & Dec. control | |
| Manual feed | Rapid traverse Jog : 0~2,000 mm/min (79 ipm) Manual handle : x1, x10, x100 pulses Reference position return |
| Cutting Feed command | Direct input F code |
| Feedrate override | 0 ~ 200% (10% Unit) |
| Rapid traverse override | 1%, F25%, 50%, 100% |
| Override cancel | |
| Feed per minute | G98 |
| Feed per revolution | G99 |
| Look-ahead block | 1 block |
| Program input | |
| Tape Code | EIA / ISO |
| Optional block skip | 9 ea |
| Program stop / end | M00, M01 / M02, M30 |
| Maximum command unit | ± 999,999.999 mm (± 99,999.9999 inch) |
| Plane selection | X-Y : G17 / Z-X : G18 / Y-Z : G19 |
| Workpiece coordinate system | G52, G53, 6 pairs (G54 ~ G59) |
| Manual absolute | Fixed ON |
| Programmable data input | G10 |
| Sub program call | 10 folds nested |
| Custom macro | #100 ~ #199, #500 ~ #999 |
| G code system | A, B/C |
| Programmable mirror image | G51.1, G50.1 |
| G code preventing buffering | G4.1 |
| Direct drawing dimension program | Including Chamfering / Corner R |
| Conversational Program | SmartGuide-i |

| Program input | |
|---|--|
| Multiple repetitive cycles | 1, 11 |
| Canned cycle for turning | |
| Auxiliary function / Spindle speed function | |
| Auxiliary function | M & 4 digit |
| Level-up M Code | High speed / Multi / Bypass M code |
| Spindle speed function | S & 5 digit, Binary output |
| Spindle override | 0% ~ 150% (10% Unit) |
| Multi position spindle orientation | M19 (S##) |
| Rigid tapping | |
| Constant surface speed control | G96, G97 |
| Tool function / Tool compensation | |
| Tool function | T & 2 digit + Offset 2 digit |
| Tool life management | |
| Tool offset pairs | 128 pairs |
| Tool nose radius compensation | G40, G41, G42 |
| Geometry / Wear compensation | |
| Direct input of offset measured B | |
| Editing function | |
| Part program storage size | 5,120m (2MB) |
| No. of registerable programs | 1,000 ea |
| Program protect | |
| Background editing | |
| Extended part program editing | Copy, move and change of NC program |
| Memory card program edit | |
| Data input / output & Interface | |
| I/O interface | CF card, USB memory Embedded Ethernet interface |
| Screen hard copy | |
| External message | |
| External key input | |
| External workpiece number search | |
| Automatic data backup | |
| Setting, display and diagnosis | |
| Self-diagnosis function | |
| History display & Operation | Alarm & Operator message & Operation |
| Run hour / Parts count display | |
| Maintenance information | |
| Actual cutting feedrate display | |
| Display of spindle speed / T code | |
| Graphic display | |
| Operating monitor screen | Spindle / Servo load etc. |
| Power consumption monitoring | Spindle & Servo |
| Spindle / Servo setting screen | |
| Multi language display | Support 24 languages |
| Display language switching | Selection of 5 optional Languages |
| LCD Screen Saver | Screen saver |
| Unexpected disturbance torque | BST (Back spin torque limit) |
| Function for machine type | |
| Cs contour control (C & A axis) | Mill, MS, Y, SY, LF-Mill, TTMS, TTSY |
| Polar coordinate interpolation | Mill, MS, Y, SY, LF-Mill, TTMS, TTSY |
| Cylindrical interpolation | Mill, MS, Y, SY, LF-Mill, TTMS, TTSY |
| Polygon turning (2 Spindles) | Mill, MS, Y, SY, LF-Mill, TTMS, TTSY |
| Canned cycle for drilling | Mill, MS, Y, SY, LF-Mill, TTMS, TTSY |
| Spindle orientation expansion | MS, SY TTS, TTMS, TTSY |
| Spindle synchronous control | MS, SY TTS, TTMS, TTSY |
| Torque control | MS, SY TTS, TTMS, TTSY |
| Y axis offset | Y, SY, TTSY |
| Arbitrary angular control | Y, SY, TTSY |
| Composite / Superimposed control | MS, SY, TTS, TTMS, TTSY |
| Balance cutting | TTS, TTMS, TTSY |
| Option | |
| Fast ethernet | Needed option board |
| Data server | Needed option board |
| Protection of data at 8 levels | |
| Tool offset pairs | 200 pairs |
| Helical interpolation | |
| Optional block skip | 40 ea, 200 ea (AICC 11) |

Figures in inch are converted from metric values.

The FANUC controller specifications are subject to change based on the policy of company CNC supplying.

GLOBAL NETWORK



HEADQUARTER



R&D Center/Factory
153, Jeongdong-ro, Seongsan-gu,
Changwon-si, Gyeongsangnam-do, Korea
TEL : +82 55 280 9114



Overseas Sales Team /R&D Center
37, Cheoldobangmulgwan-ro, Uliwang-si,
Gyeonggi-do, Korea
TEL : +82 31 8090 2539

EUROPE



HYUNDAI WIA Machine Tools Europe
Alexander-Fleming-Ring 57, DE-65428
Russelsheim am Main, Germany
TEL : +49-0-6142-9256-0

AMERICA



HYUNDAI WIA Machine Tools America
450 Commerce Blvd, Carlstadt, NJ 07072, USA
TEL : +1-201-987-7298

ASIA



HYUNDAI WIA Machine Tools China
Company No.16 Fenghuang Road, Fenghuang
Town, Zhangjiagang City, Jiangsu Province, China
TEL : +86-512-5637-9719

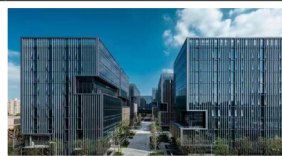

Shanghai Branch Office (China)
3F-04, MT1, MixC Park, No.229, HaowenRoad,
Minhang District, Shanghai, China
TEL : +86-21-6427-9885



Chengdu Branch Office (China)
Room 409B, Building 1, No.333, Yizhou Road,
High-Tech District, Chengdu, China
TEL : +86-21-5952-3256

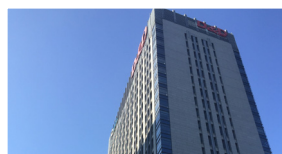

Qingdao Branch Office (China)
Room 702, Yulong International Center, Building
1, No. 178-2, Haier Road, Laoshan District,
Qingdao, China. C.P. 266035
TEL : +86-28-8666-2985

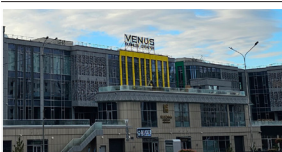

CIS Branch Office
050051, Kazakhstan, Almaty, Elebekova street 10,
B.3, Office no.103
TEL : +7-(727)-355-7133



India Branch Office
#4/169, 1st Floor, LOTTE BLDG, Rajiv Gandhi
Salai, (OMR), Kandanchavadi, Chennai -600 096,
Tamilnadu, India
TEL : +91-76049-01618



You Tube HYUNDAI WIA MT
www.youtube.com/HYUNDAIWIAMT

CREATING VALUE IN SEAMLESS MOBILITY

With its top-quality HYUNDAI WIA machine tool creates a new and better world.



<http://machine.hyundai-wia.com>
HYUNDAI WIA Machine Tools
Global Links