

KIT Series

KIT250 | KIT4500 | KIT60G

HYUNDAI WIA Gang Type CNC Turning Center

Technical Leader

The Gang Type CNC Turning Center KIT Series, designed by Hyundai WIA with years of expertise and the latest technology, is a gang tool CNC Turning Center which maximizes productivity through high speed and high performance mechanisms.

		KIT250	KIT4500	KIT60G
Max. Swing	mm(in)	Ø160 (Ø6.3")	Ø530 (Ø20.9")	Ø780 (Ø30.7")
Max. Turning Length	mm(in)	150 (5.9")	300 (11.8")	530 (20.9")
Chuck Size	inch	5"	6" [Big Bore : 8"]	10"
Bar Capacity	mm(in)	Ø32 (Ø1.3")	Ø51 (Ø2") [Big Bore : Ø65 (Ø2.6")]	Ø65 (Ø2.6")
Sp. Speed	r/min	7,000	6,000 [6,000] [Electric Chuck : 6,000] [Big Bore : 4,000] [Big Bore : 4,000]	4,000
Sp. Motor (Max./Cont.)	kW(HP)	5.5/3.7 (7.4/5)	15/11 (20/15) [25/10.5 (33.5/14.1)] [Electric Chuck : 20/10.5 (26.8/14.1)] [Big Bore : 15/11 (20/15)] [Big Bore : 25/10.5 (33.5/14.1)]	15/11 (20/15)
Travel (X/Z)	mm(in)	250/200	450/300 (17.7"/11.8")	450/550
No. of Tools	EA	Block Tool : 4	Block Tool : 6	Block Tool : 6 [Grinding Sp.]

KIT Series

Economical Gang Type CNC Turning center

- One-piece bed structure with high rigidity
- Stabilized unit structure to minimize thermal displacement
- Reduction of belt damage and spindle vibration through decrease of spindle belt length (KIT4500)
- Optimal design for automation
- Compact design suitable for installation in restricted space



01 BASIC STRUCTURE

Which Can Cover All Machining Process with Only One Initial Setting

LM Guideway

- Rapid Traverse Rate (X/Z)
- KIT250 : 24/30 m/min
- KIT4500 : 30/36 m/min
- KIT60G : 36/36 m/min

Block Tool

- No. of Tools
- KIT250 : 4 EA
- KIT4500 : 6 EA
- KIT60G : 6 EA
- [Grinding Sp. Opt.]

High Precision Spindle

- designed with angular contact ball bearings.
- KIT250 : 5" | 7,000 r/min
- KIT4500 : 6" | 6,000 r/min
- KIT60G : 10" | 4,000 r/min

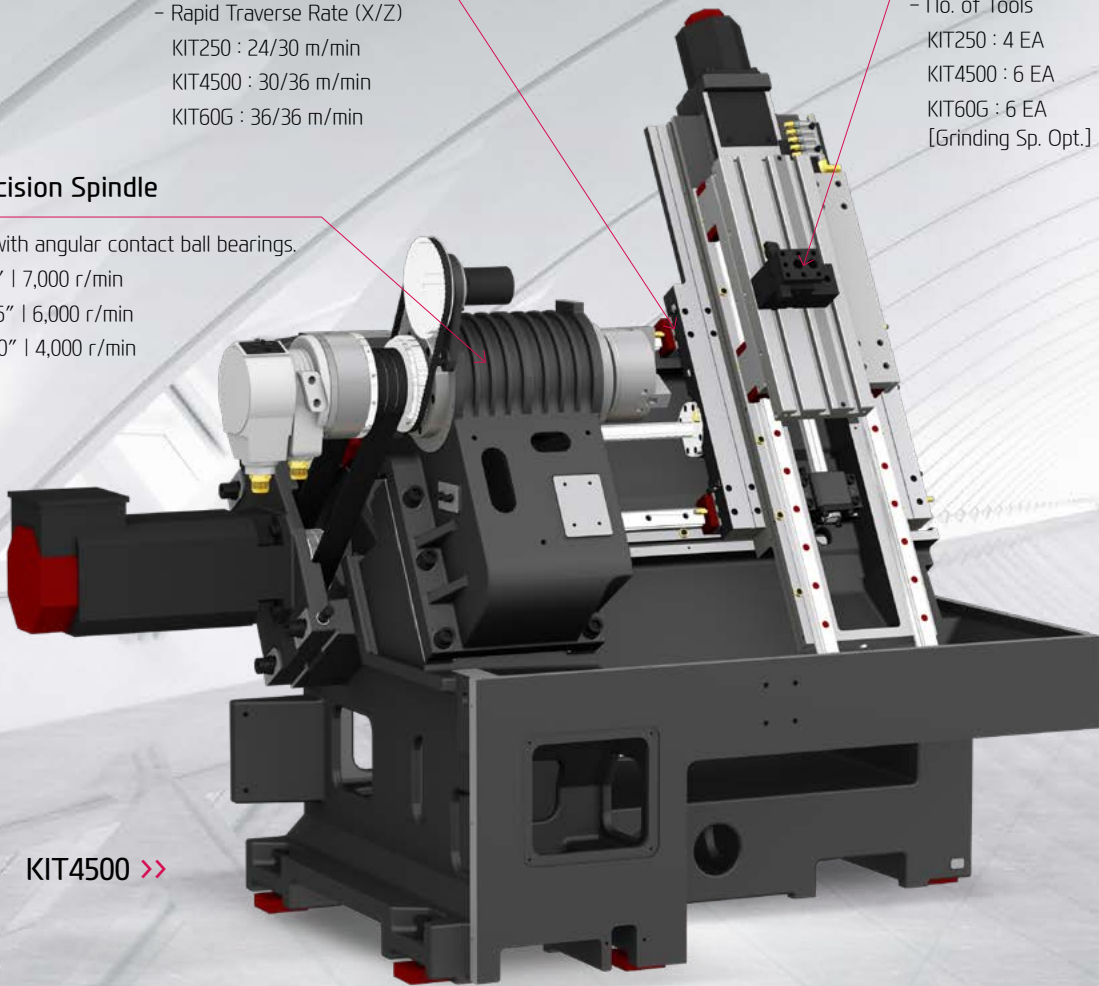

KIT4500 >>

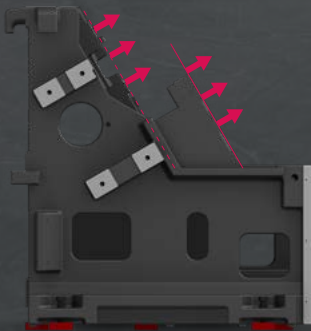

60° Slant Bed Structure (KIT4500)

The application of 60° slant bed ensures excellent chip processing with easy access to the chuck during your tool setting for your increased convenience.

Especially, thermal displacement has been greatly improved compared to that of the existing machine as the thermal expansion directions of both the spindle and table are identical according to the thermal displacement of the bed.

40% reduction of combined thermal displacement

REDUCTION OF NON-CUTTING TIME BY FAST RAPID SPEED

ALL-IN-ONE TYPE OF BED

KIT250 – Flat Type Bed

The bed flushing unit is installed as standard to effectively resolve chip disposal problems. The gang tool is attached to a flat type bed to ensure high precision during machining process.

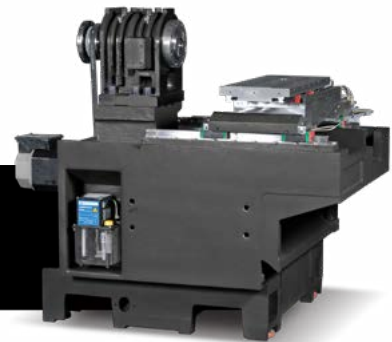

KIT60G – 45° Slant Bed Structure

The KIT60G features a 45° slant bed design which is developed through finite element analysis (FEA) to absorb vibration and minimize thermal growth.

GUIDEWAY

LM Guideway

All axis of KIT Series is designed with LM Guides. It reduces machining noise and enhances productivity through faster traverse rate.

Ball Screw (KIT4500)

Thermal displacement on the X axis has been reduced by 50% compared to that of the existing equipment due to improvements on the carriage structure on the X axis. Especially, the supporting capability has been improved as the support bearing of ball screws is expanded from the existing 2 EA to 3 EA on the X axis.

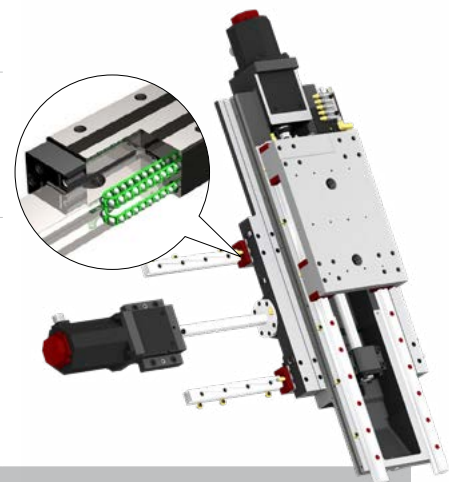

Thermal displacement improvement on the X axis : 50% reduction

Model	KIT250	KIT4500	KIT60G
Rapid Traverse Rate (X/Z)	24/30 m/min	30/36 m/min	36/36 m/min
Travel (X/Z)	250/200 mm (9.8"/7.9")	450/300 mm (17.7"/11.8")	450/550 mm (17.7"/21.7")

02 SPINDLE & BLOCK TOOL

Long Lasting, High Accuracy & Excellent Performance CNC Turning Center

Spindle Specifications

[] : Option

Model	Chuck Size	Spindle Speed	Motor (Max./Cont.)	Torque (Max./Cont.)
KIT250	5"	7,000 rpm	5.5/3.7 kW (7.4/5.5 HP)	48/32.4 N·m (35.4/23.9 lbf·ft)
KIT4500 (FANUC)	(Hydraulic) 6"	6,000 rpm	15/11 kW (20/15 HP)	95.5/70 N·m (70.4/51.6 lbf·ft)
	[(Hydraulic) 8"]	[4,000 rpm (Big Bore)]	15/11 kW (20/15 HP)	[191/140 N·m (140.9/103.3 lbf·ft)]
KIT4500 (SIEMENS)	[(Hydraulic) 6"]	[6,000 rpm]	25/10.5 kW (33.5/14.1 HP)	[120/50 N·m (88.5/36.9 lbf·ft)]
	[(Hydraulic) 8"]	[4,000 rpm (Big Bore)]	25/10.5 kW (33.5/14.1 HP)	[238/100 N·m (175.5/73.8 lbf·ft)]
	[(Electric) 6"]	[6,000 rpm]	20/10.5 kW (26.8/14.1 HP)	[143/75 N·m (105.5/55.3 lbf·ft)]
KIT60G	10"	4,000 rpm	15/11 kW (20/15 HP)	191/140 N·m (140.9/103.3 lbf·ft)

HIGH ACCURACY & EXCELLENT PERFORMANCE

SPINDLE

High Precision Spindle

The high precision spindle is designed with angular contact ball bearings. The bearings minimize thermal displacement even at high speed.

Application of 3V Belt (KIT4500)

The belt slip is reduced by changing the existing scrum belt to the V-ribbed belt. The span between motors in the spindle is optimized to improve spindle vibration and belt life.



High Frequency Spindle Motor (KIT60G)

By preparing for high frequency spindle as an option, the processing area has been increased. (BT40, BT50 Opt.)

Drill/PCD Processing :As it is able to perform the drilling and PCD processing using a high frequency of spindle, the processing width has increased.

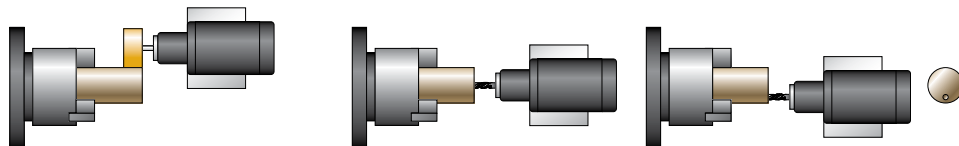

BLOCK TOOL

Gang Type Block Tool

With Tool-To-Tool time reduced, productivity has been improved in the machining of small sized parts.



Model	No. of Tool	Tool Size (O.D/I.D)	Table Size
KIT250	4 EA	□ 20/∅20 mm (□ 0.8"/∅0.8")	200×550 mm (7.9"/21.7")
KIT4500	6 EA	□ 20/∅32 mm (□ 0.8"/∅1.3")	200×550 mm (7.9"/21.7")
KIT60G	6 EA [Opt. Grinding Sp.]	□ 25/∅32 mm (□ 1"/∅1.3")	200×600 mm (7.9"/23.6")

03 USER CONVENIENCE

Various Devices for User Friendly

BAR FEEDER SYSTEM OPTION

Bar Feeder

Bar feeder system enables automation which leads to efficiency improvement.



Parts Catcher

An optional parts catcher collects finished parts without the need to open the door, adding productivity, especially when a bar feeder is attached.



Parts Conveyor

The parts conveyor transfers the finished workpiece unloaded by the parts catcher for user convenience.



Auto Door

Using M-code, the doors can be automatically opened and closed which brings productivity and convenience for automation.



Auto Shutter

Using auto shutter, automation system with gantry loader is possible without opening the machine's door.

OUTSTANDING PRODUCTIVITY (KIT4500)

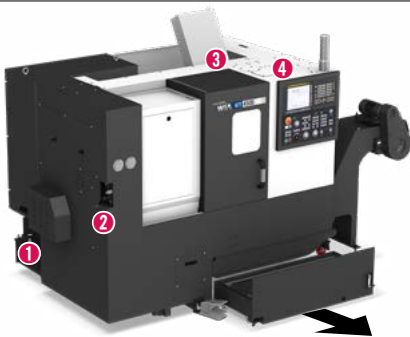

Independent separation of only the coolant tank without the separation of chip pan and chip conveyor (common for the side and back)

- ❶ Arrangement of hydraulic unit on the backend
- ❷ 2-directional (front / left side) pressure controller
- ❸ Top hole for the dust collector installation
- ❹ Sockets for piping option such as air tool, hydraulic, etc. (3 points)

Optimal structure for user convenience

Door opening width 495 mm (19.5")

Coolant Capacity 120 ℓ (31.7 gal)

< Compared to previous machine 20 ℓ (5.3 gal) UP >

Dual Filter

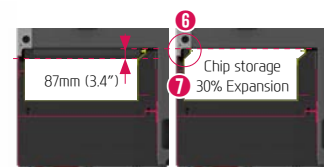
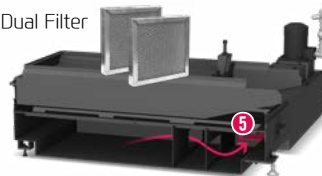

- ❺ Enhanced coolant filter capability
Filter capability has been improved by applying a dual filter in the zigzag filtering partition structure.
- ❻ Leakage prevention structure
Leak is prevented by tightening the chip box shoot surface close to the bed shoot floor through controlling the chip box height.
- ❼ Expansion of chip storage space
The chip storage space under the bed has been expanded by 30% compared to the previous model.

ELECTRIC CHUCK SYSTEM (KIT4500) **OPTION**

- Hydraulic devices that allows you to save space and operate sustainably
- Precise control by electric power enables fine adjustment of clamping force
- Fuel-efficient mechanical system with locking clamp mechanism for rotational machining operations
- Motorized, energy-saving spindles with integrated clamping and rotating system

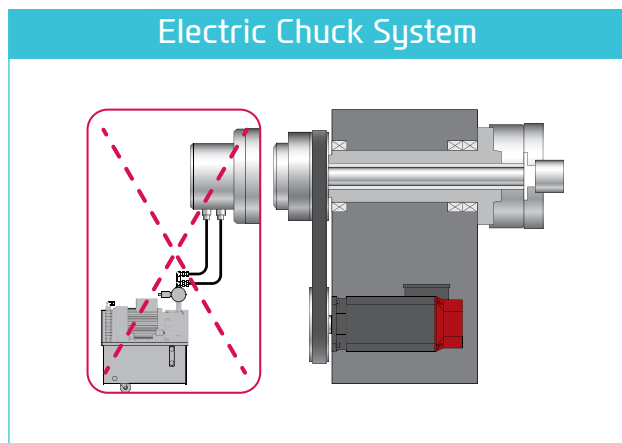
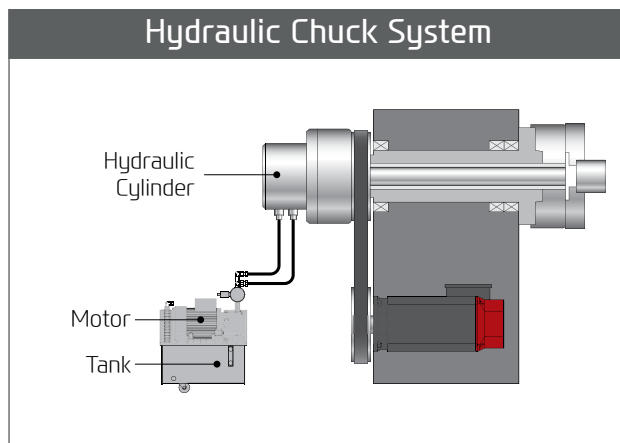
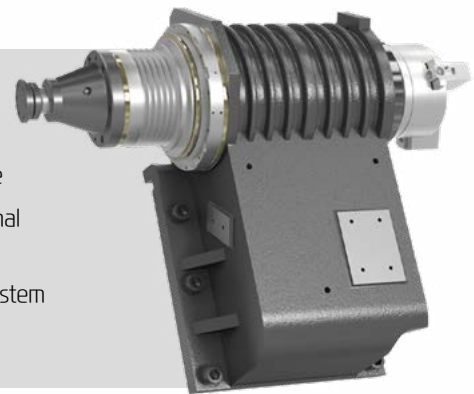

SERVO LEARNING OSCILLATION FUNCTION FOR CHIP BREAKING **OPTION**

- **Machining Method** : he tool cuts the workpiece moving in a zigzag pattern. (Oscillating) → Air cut section occurs → Long chips break
- **Advantage** : Increase tool life, Enhance surface finishing, Improve chip disposal
- **Machine** : All turning centers with FANUC controller (Option)

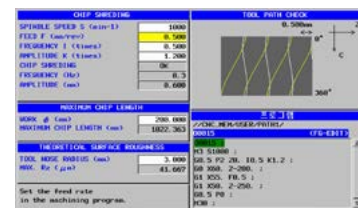
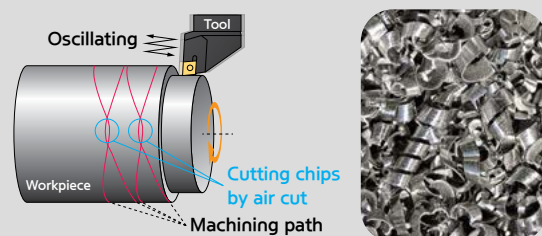

(Developed special screen page for servo learning oscillation function / Even when this function is applied, the cycle time remains same.)

SPECIFICATIONS

KIT250 Standard & Optional

Spindle		KIT250
Main Spindle	5"	●
Hollow Chuck 3 Jaw	6"	○
Main Spindle	5"	☆
Solid Chuck 3 Jaw	6"	☆
Standard Soft Jaw (1set)		●
Chuck Clamp Foot Switch		●
2 Steps Hyd. Pressure Device		☆
Chuck Open/Close Confirmation Device		●
Spindle Inside Stopper		☆
5" Index		○
Cs-Axis (0.001")		☆
Block Tool		
Tool Holder		●
Boring Sleeve		●
Drill Socket		●
U-Drill Holder		☆
U-Drill Holder Sleeve		☆
Rotating Tool Head (X,Z Axis)		☆
Tail Stock & Steady Rest		
Manual Tail Stock		-
Coolant & Air Blow		
Standard Coolant (Nozzle)		●
Chuck Coolant (Upper Chuck)		○
Gun Coolant		○
Through Spindle Coolant (Only for Special Chuck)		☆
Chuck Air Blow (Upper Chuck)		○
Air Gun		○
Through Spindle Air Blow (Only for Special Chuck)		☆
High Pressure Coolant	6Bar (87 psi)	○
Power Coolant System (For Automation)		☆
Bed Coolant		○
Coolant Chiller		☆
Chip Disposal		
Coolant Tank	115 ℓ (30.4 gal)	●
Chip Conveyor (Hinge/Scraper/Screw)	Front (Right)	-
	Front (Rear)	○
Special Chip Conveyor (Drum Filter)		☆
Chip Wagon	Standard (180 ℓ [47.5 gal])	○
	Swing (200 ℓ [52.8 gal])	○
	Large Swing (290 ℓ [76.6 gal])	○
	Large Size (330 ℓ [87.2 gal])	○
	Customized	☆
S/W		
Dialogue Program (HW-DPRO)		-
DFC software (HW-eDNC)		○
Smart Guide-i : FANUC		○
Smart S/W		☆

● : Standard ○ : Option ☆ : Prior Consultation - : Non Applicable

Safety Device		KIT250
Total Splash Guard		●
Chuck hydraulic pressure maintenance interlock		○(CE:●)
Electric Device		
Call Light	1Color : ●	○
Call Light & Buzzer	3Color : ● ● ● B	○
Electric Cabinet Light		○
Remote MPG		○
Work Counter	Digital	○
Total Counter	Digital	○
Tool Counter	Digital	○
Multi Tool Counter	Digital	○
Electric Circuit Breaker		○
AVR (Auto Voltage Regulator)		☆
Transformer	15kVA	○
Auto Power Off		○
Measurement		
Q-Setter		-
Work Close Confirmation Device (Only for Special Chuck)	TACO	○
	SMC	○
Linear Scale	X/Z Axis	-
Coolant Level Sensor (Only for Chip Conveyor)		☆
Environment		
Air Conditioner		○
Oil Mist Collector		☆
Oil Skimmer		○
MQL (Minimal Quantity Lubrication)		☆
Fixture & Automation		
Auto Door		○
Auto Shutter (Only for Automatic System)		☆
Sub Operation Pannel		☆
Bar Feeder Interface		○
Extra M-Code 4ea		○
Automation Interface		☆
I/O Extension (IN & OUT)	16 Contact	○
	32 Contact	○
Parts Catcher		○
Parts Conveyor		☆
Semi Automation System (Only for Bearing Parts)		☆
Semi Automation System (General Turning)		☆
Hyd. Device		
Standard Hyd. Cylinder	Hollow	●
Standard Hyd. Unit	35bar (507.6 psi)/ 15 ℓ (4 gal)	●
ETC		
Tool Box		●
Customized Color	Need Munsel No.	☆
CAD & CAM Software		☆
Thermal displacement compensation		○

❖ 4 channel of TDC(Thermal Displacement Compensation) device is recommended, when more than 6 bar of high pressure coolant is applied, for the high quality machining.

Specifications are subject to change without notice for improvement. / Please refer to the S/W catalog (iRIS) for details by S/W product.

SPECIFICATIONS

KIT4500 Standard & Optional

● : Standard ○ : Option ☆ : Prior Consultation - : Non Applicable

Spindle		KIT4500
Main Spindle Hollow Chuck 3 Jaw	6"	●
	8"	○
	10"	-
Main Spindle Solid Chuck 3 Jaw	6"	○
	8"	☆
	10"	-
Electric Chuck (SIEMENS)	6"	○
Bar Capacity	Ø45 (Ø1.8")	○
Standard Soft Jaw (1set)		●
Chuck Clamp Foot Switch		●
2 Steps Hyd. Pressure Device		○
Spindle Inside Stopper		○
5° Index		○
Cs-Axis (0.001")		○
Block Tool		
Tool Holder		●
Boring Sleeve		●
Drill Socket		●
U-Drill Holder		○
U-Drill Holder Sleeve		○
Ø32 (Ø1.3") Boring Holder		●
Rotating Tool Head (X,Z Axis)		☆
Tail Stock & Steady Rest		
Manual Tail Stock		-
Coolant & Air Blow		
Standard Coolant (Nozzle)		●
Chuck Coolant (Upper Chuck)		○
Gun Coolant		○
Through Spindle Coolant (Only for Special Chuck)		☆
Chuck Air Blow (Upper Chuck)		○
Air Gun		○
Through Spindle Air Blow (Only for Special Chuck)		☆
High Pressure Coolant	0.5Bar (7.3 psi) 6Bar (87 psi)	● ○
Power Coolant System (For Automation)		☆
Coolant Chiller		☆
Chip Disposal		
Coolant Tank	120 ℓ (31.7 gal)	●
	130 ℓ (34.3 gal)	-
Chip Conveyor (Hinge/ Scraper/Screw)	Front (Right)	○
	Front (Rear)	○
Special Chip Conveyor (Drum Filter)		☆
Chip Wagon	Standard (180 ℓ [47.5 gal])	○
	Swing (200 ℓ [52.8 gal])	○
	Large Swing (290 ℓ [76.6 gal])	○
	Large Size (330 ℓ [87.2 gal])	○
	Customized	☆
S/W		
Dialogue Program (HW-DPRO)		-
DNC software (HW-eDNC)		○
Smart Guide-i : FANUC		○
Smart S/W		☆

Safety Device		KIT4500
Total Splash Guard		●
Chuck hydraulic pressure maintenance interlock		○(CE:●)
Electric Device		
Call Light	1Color : ●	○
Call Light & Buzzer	3Color : ● ■ ■ B	○
Electric Cabinet Light		○
Controller	FANUC SIEMENS	● ○
Remote MPG		○
Work Counter	Digital	○
Total Counter	Digital	○
Tool Counter	Digital	○
Multi Tool Counter	Digital	○
Electric Circuit Breaker	FANUC	○
	SIEMENS	-
AVR (Auto Voltage Regulator)		☆
Transformer	20kVA	○
Auto Power Off		○
Measurement		
Q-Setter		-
Work Close Confirmation Device (Only for Special Chuck)	TACO	○
	SMC	○
Linear Scale	X/Z Axis	○
Coolant Level Sensor (Only for Chip Conveyor)		☆
Environment		
Air Conditioner		○
Oil Mist Collector		☆
Oil Skimmer		○
MQL (Minimal Quantity Lubrication)		☆
Fixture & Automation		
Auto Door		○
Auto Shutter (Only for Automatic System)		○
Sub Operation Pannel		☆
Bar Feeder Interface		○
Extra M-Code 4ea		○
Automation Interface		☆
I/O Extension (IN & OUT)	16 Contact	○
	32 Contact	○
Parts Catcher		○
Parts Conveyor		☆
Semi Automation System (Front)		☆
Hyd. Device		
Standard Hyd. Cylinder	Hollow	●
Standard Hyd. Unit	35bar (507.6 psi)/ 12 ℓ (3.2 gal)	-
	35bar (507.6 psi)/ 15 ℓ (4 gal)	●
ETC		
Tool Box		●
Customized Color	Need Munsel No.	☆
CAD & CAM Software		☆
Thermal displacement compensation		○

◆ 4 channel of TDC(Thermal Displacement Compensation) device is recommended, when more than 6 bar of high pressure coolant is applied, for the high quality machining.

Specifications are subject to change without notice for improvement. / Please refer to the S/W catalog (IRIS) for details by S/W product.

SPECIFICATIONS

KIT60G Standard & Optional

Spindle		KIT60G
Main Spindle	10"	●
Hollow Chuck 3 Jaw	12"	-
Main Spindle	10"	☆
Solid Chuck 3 Jaw	12"	-
Scroll Chuck	12"	○
Grinding Spindle		○
Standard Soft Jaw (1set)		●
Chuck Clamp Foot Switch		●
2 Steps Hyd. Pressure Device		○
Chuck Open/Close Confirmation Device		●
Spindle Inside Stopper		☆
5" Index		○
Cs-Axis (0.001")		☆
Block Tool		
Tool Holder		●
Boring Sleeve		●
Drill Socket		●
U-Drill Holder		☆
U-Drill Holder Sleeve		☆
Rotating Tool Head (X,Z Axis)		☆
Tail Stock & Steady Rest		
Manual Tail Stock		-
Coolant & Air Blow		
Standard Coolant (Nozzle)		●
Chuck Coolant (Upper Chuck)		○
Gun Coolant		○
Through Spindle Coolant (Only for Special Chuck)		☆
Chuck Air Blow (Upper Chuck)		○
Air Gun		○
Through Spindle Air Blow (Only for Special Chuck)		☆
High Pressure Coolant	6Bar (87 psi)	○
Power Coolant System (For Automation)		☆
Bed Coolant		○
Coolant Chiller		☆
Chip Disposal		
Coolant Tank	115ℓ (30.4 gal)	●
Chip Conveyor (Hinge/Scraper/Screw)	Front (Right) Front (Rear)	○ ○
Special Chip Conveyor (Drum Filter)		☆
Chip Wagon	Standard (180ℓ [47.5 gal])	○
	Swing (200ℓ [52.8 gal])	○
	Large Swing (290ℓ [76.6 gal])	○
	Large Size (330ℓ [87.2 gal])	○
	Customized	☆
S/W		
Dialogue Program (HW-DPRO)		-
DFC software (HW-eDFC)		○
Smart Guide-i : FANUC		○
Smart S/W		☆

● : Standard ○ : Option ☆ : Prior Consultation - : Non Applicable

Safety Device		KIT60G
Total Splash Guard		●
Chuck hydraulic pressure maintenance interlock		○ (CE: ●)
Electric Device		
Call Light	1Color : ●	○
Call Light & Buzzer	3Color : ● ● ● B	○
Electric Cabinet Light		○
Remote MPG		○
Work Counter	Digital	○
Total Counter	Digital	○
Tool Counter	Digital	○
Multi Tool Counter	Digital	○
Electric Circuit Breaker		○
AVR (Auto Voltage Regulator)		☆
Transformer	15kVA	○
Auto Power Off		○
Measurement		
Q-Setter		-
Work Close Confirmation Device (Only for Special Chuck)	TACO SMC	○ ○
Linear Scale	X/Z Axis	-
Coolant Level Sensor (Only for Chip Conveyor)		☆
Environment		
Air Conditioner		○
Oil Mist Collector		☆
Oil Skimmer		○
MQL (Minimal Quantity Lubrication)		☆
Fixture & Automation		
Auto Door		○
Auto Shutter (Only for Automatic System)		○
Sub Operation Panel		☆
Bar Feeder Interface		○
Extra M-Code 4ea		○
Automation Interface		☆
I/O Extension (IN & OUT)	16 Contact 32 Contact	○ ○
Parts Catcher		○
Parts Conveyor		☆
Semi Automation System (Front)		☆
Hyd. Device		
Standard Hyd. Cylinder	Hollow	●
Standard Hyd. Unit	35bar (507.6 psi)/ 15ℓ (4 gal)	●
ETC		
Tool Box		●
Customized Color	Need Munsel No.	☆
CAD & CAM Software		☆

❖ 4 channel of TDC(Thermal Displacement Compensation) device is recommended, when more than 6 bar of high pressure coolant is applied, for the high quality machining.

Specifications are subject to change without notice for improvement. / Please refer to the S/W catalog (iRIS) for details by S/W product.

SPECIFICATIONS

External Dimensions

unit : mm(in)

KIT250

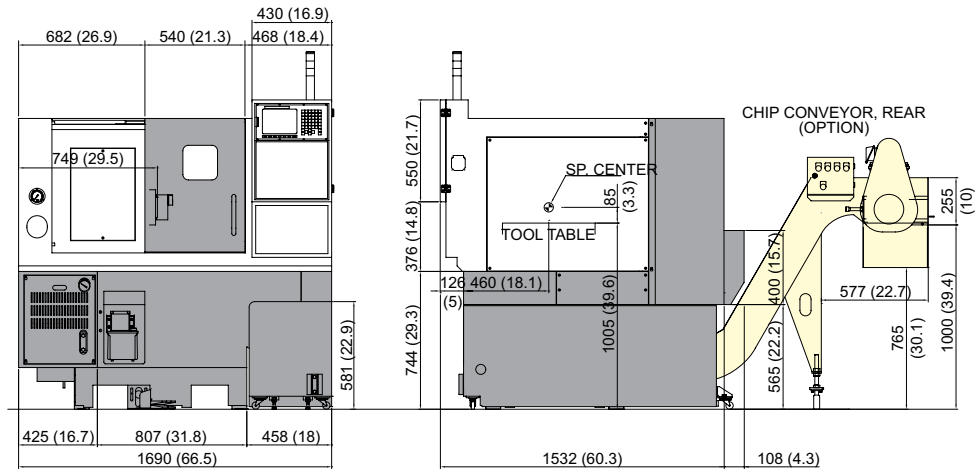

External Dimensions

unit : mm(in)

KIT60G

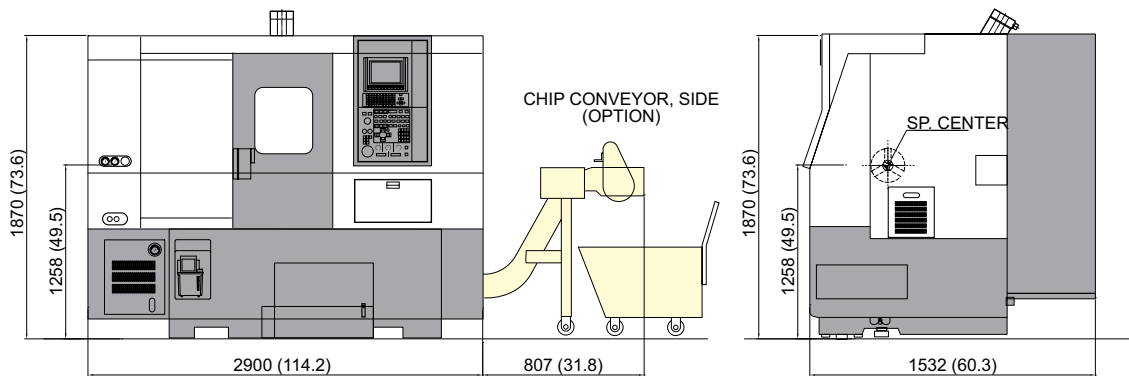

SPECIFICATIONS

External Dimensions

unit : mm(in)

Hinge/Scraper Type

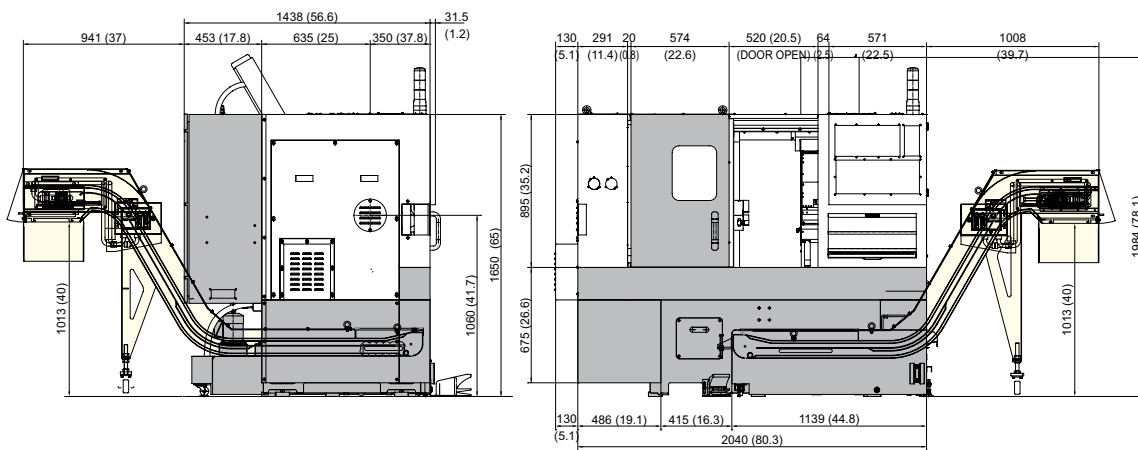

Screw Type

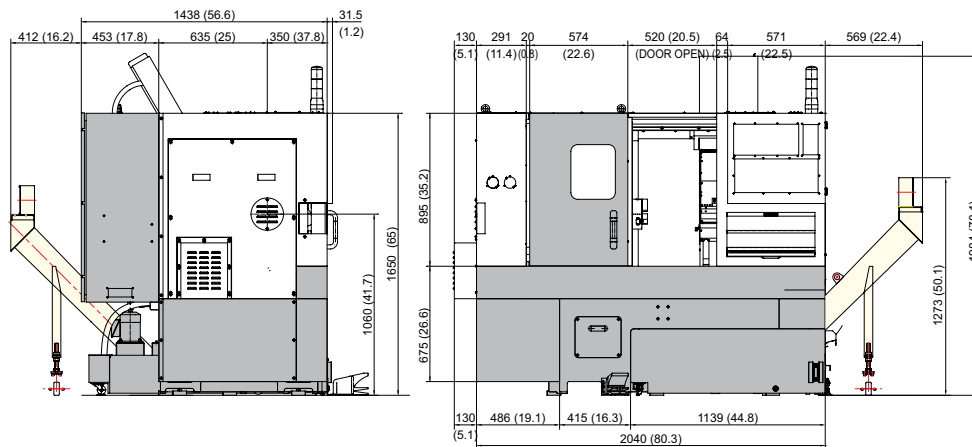

SPECIFICATIONS

FANUC Spindle Output/Torque Diagram

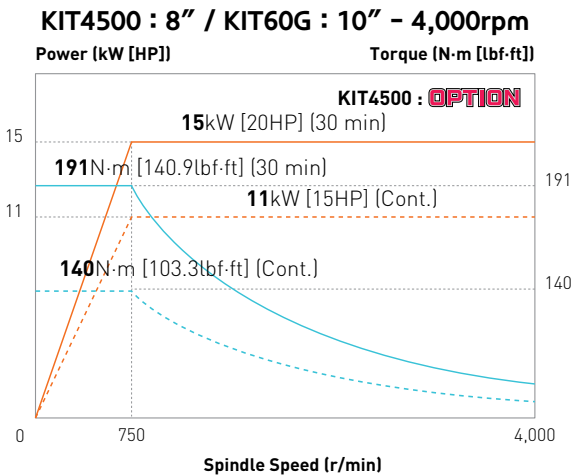
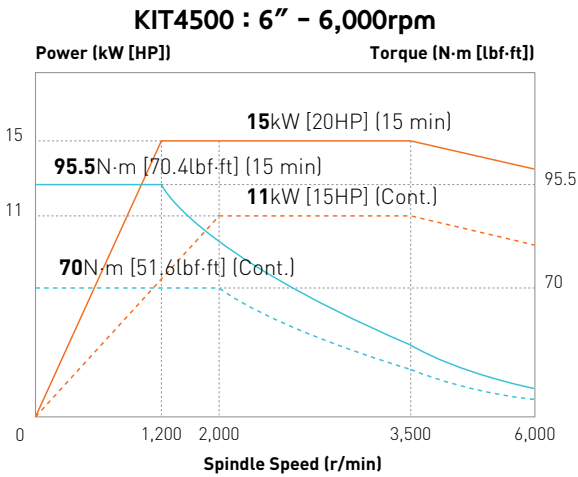
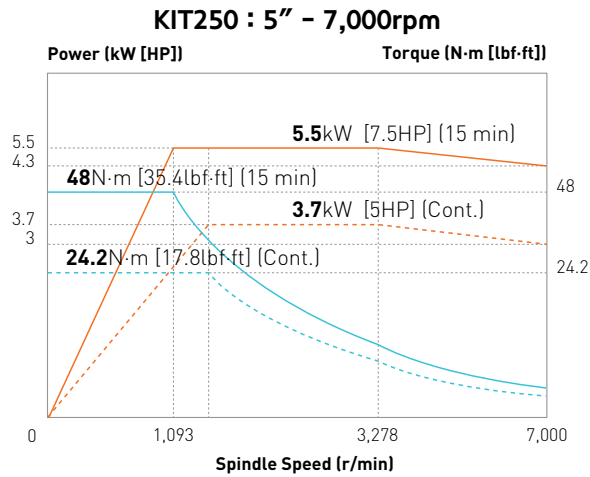

SPECIFICATIONS

SIEMENS Spindle Output/Torque Diagram

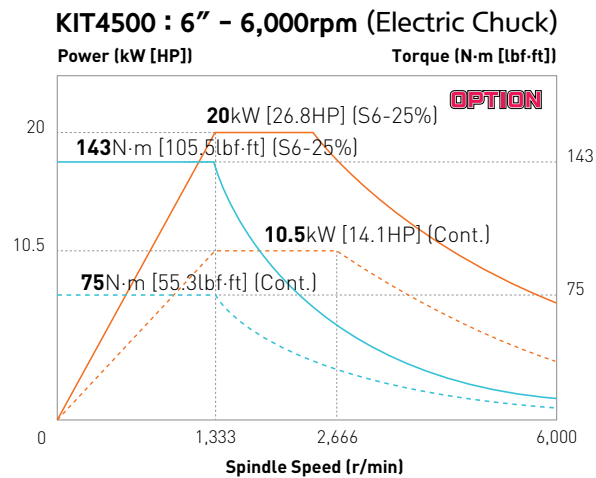
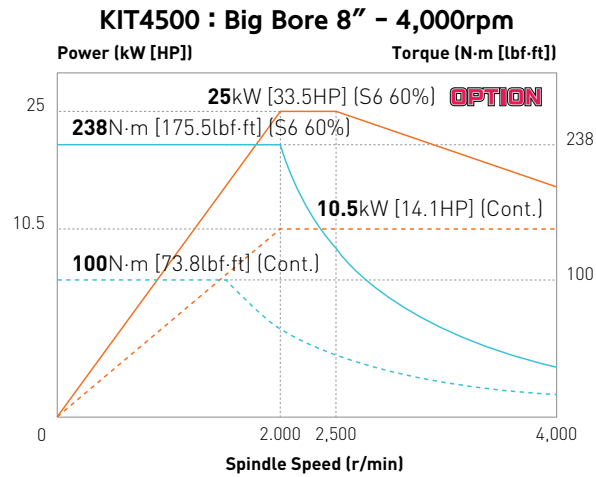
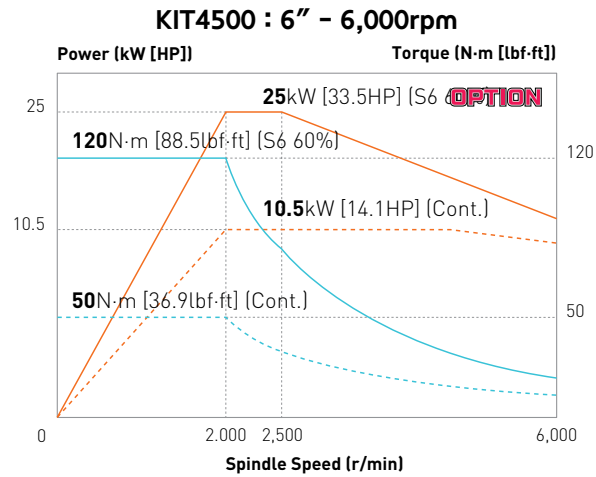

SPECIFICATIONS

The Stroke of Table

unit : mm(in)

KIT250

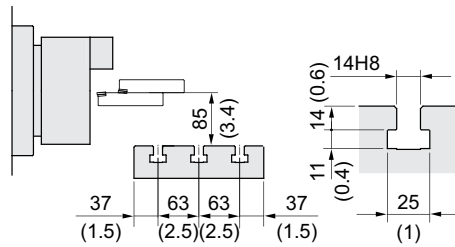
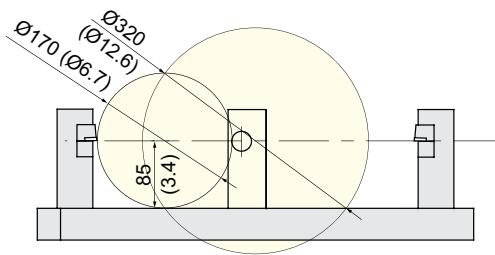
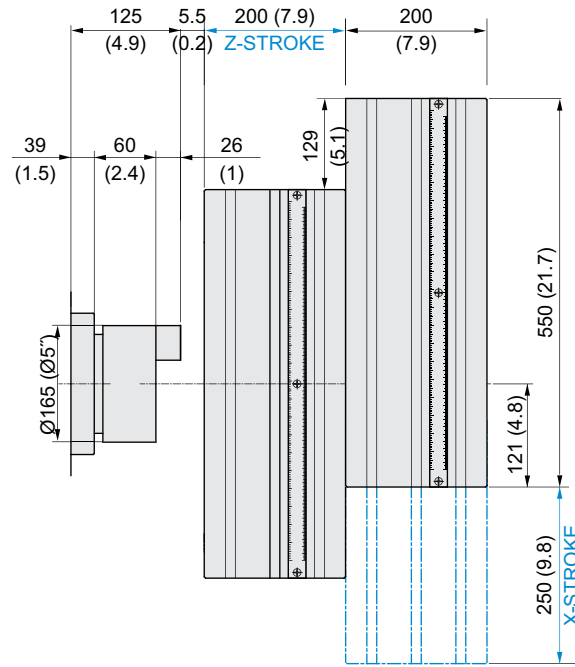

SPECIFICATIONS

The Stroke of Table

unit : mm(in)

KIT4500

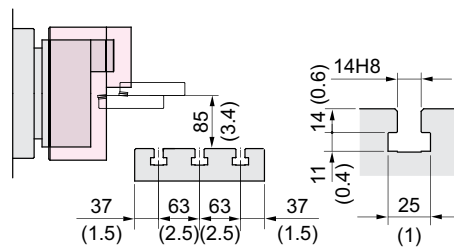
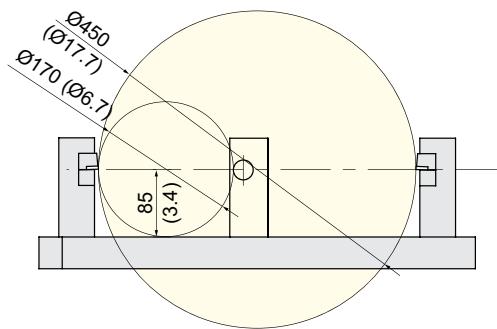
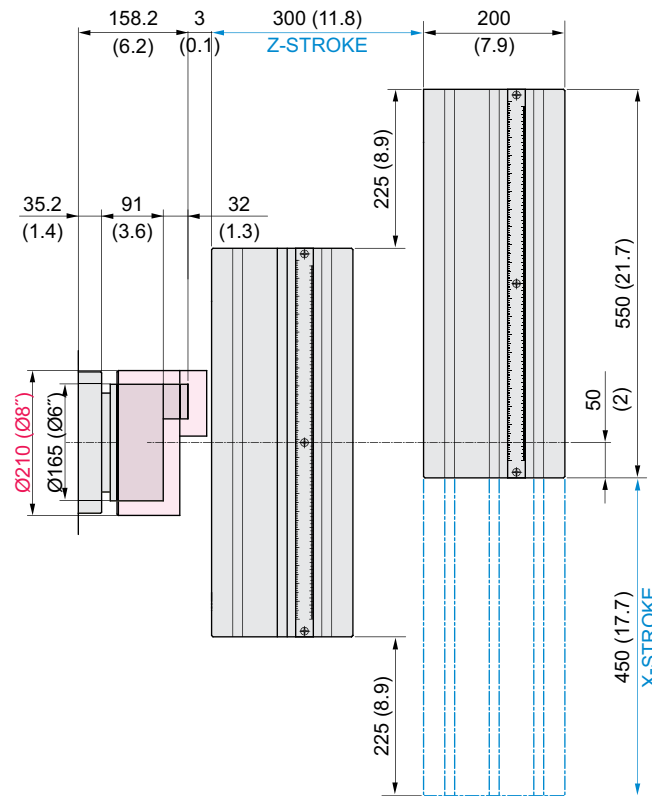

SPECIFICATIONS

The Stroke of Table

unit : mm(in)

KIT60G

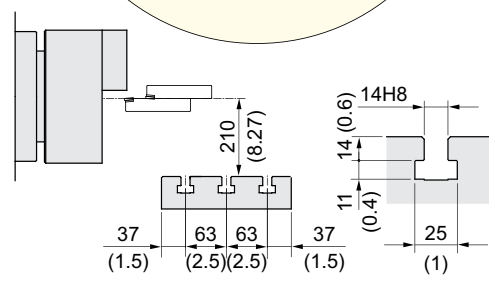
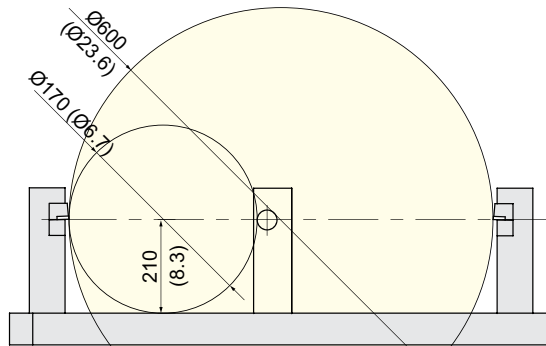
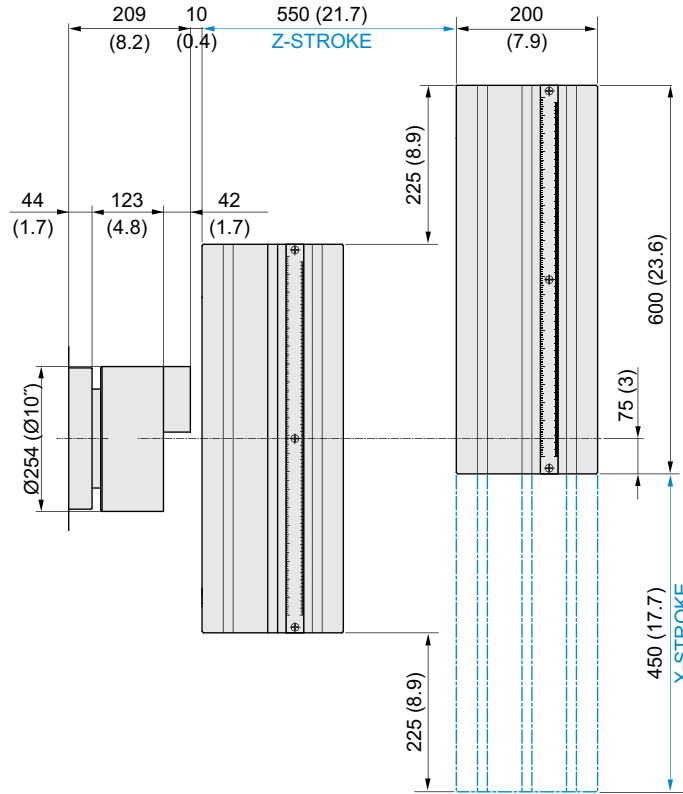

SPECIFICATIONS

Tooling Travel Range

unit : mm(in)

KIT250

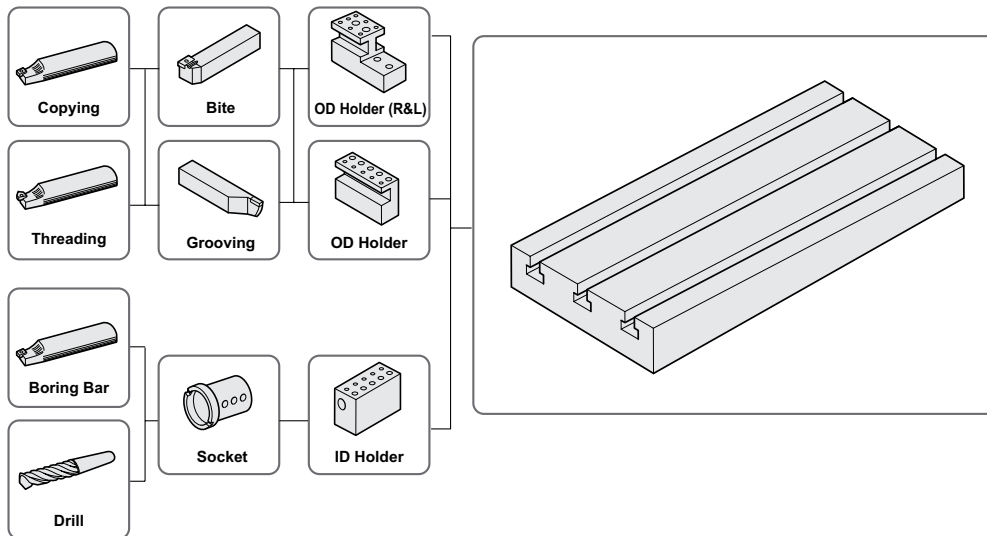

Tooling Parts Detail

ITEM			KIT250	
			mm Unit	inch Unit
Boring Holder	O.D Holder	Right/Left : $\varnothing 20$ ($\varnothing 3/4"$)	1	1
		Double : $\varnothing 20$ ($\varnothing 3/4"$)	1	1
		Right/Left : $\varnothing 25$ ($\varnothing 1"$)	-	-
		Double OD : $\varnothing 25$ ($\varnothing 1"$)	-	-
Boring Holder	I.D Holder	Single : $\varnothing 32$ ($\varnothing 1 1/4"$)	1	1
	U-Drill Holder	Tool Holder	-	-
		Cap	-	-
Socket	Boring	$\varnothing 8$ ($\varnothing 5/16"$)	1	1
		$\varnothing 10$ ($\varnothing 3/8"$)	1	1
		$\varnothing 12$ ($\varnothing 1/2"$)	1	1
		$\varnothing 16$ ($\varnothing 5/8"$)	-	-
		$\varnothing 20$ ($\varnothing 3/4"$)	-	-
		$\varnothing 25$ ($\varnothing 1"$)	-	-
	Drill	MT 1× MT 2	1	1
		MT 2	1	1
	U-Drill	$\varnothing 20$ ($3/4"$)	-	-
		$\varnothing 25$ ($1"$)	-	-

SPECIFICATIONS

Tooling Travel Range

unit : mm(in)

KIT4500

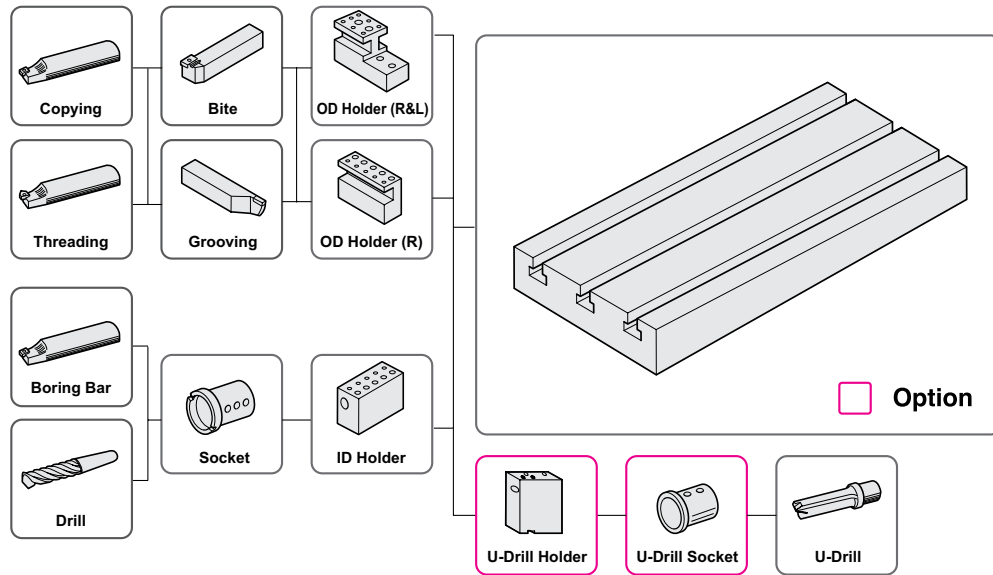

Tooling Parts Detail

ITEM		KIT4500		
		mm Unit	inch Unit	
Turning Holder	O.D Holder	Right/Left : $\varnothing 20$ ($\varnothing 3/4"$)	2	2
		Double : $\varnothing 20$ ($\varnothing 3/4"$)	1	1
		Right/Left : $\varnothing 25$ ($\varnothing 1"$)	Opt	Opt
		Double OD : $\varnothing 25$ ($\varnothing 1"$)	Opt	Opt
Boring Holder	I.D Holder	Single : $\varnothing 32$ ($\varnothing 1 1/4"$)	2	2
	U-Drill Holder	Tool Holder	Opt	-
		Cap	Opt	-
Socket	Boring	$\varnothing 8$ ($\varnothing 5/16"$)	Opt	-
		$\varnothing 10$ ($\varnothing 3/8"$)	1	1
		$\varnothing 12$ ($\varnothing 1/2"$)	1	1
		$\varnothing 16$ ($\varnothing 5/8"$)	1	1
		$\varnothing 20$ ($\varnothing 3/4"$)	Opt	Opt
		$\varnothing 25$ ($\varnothing 1"$)	Opt	Opt
	Drill	MT 1 \times MT 2	1	1
		MT 2	Opt	Opt
		$\varnothing 20$ ($3/4"$)	Opt	-
		$\varnothing 25$ ($1"$)	Opt	-

Specifications are subject to change without notice for improvement.

SPECIFICATIONS

Tooling Travel Range

unit : mm(in)

KIT60G

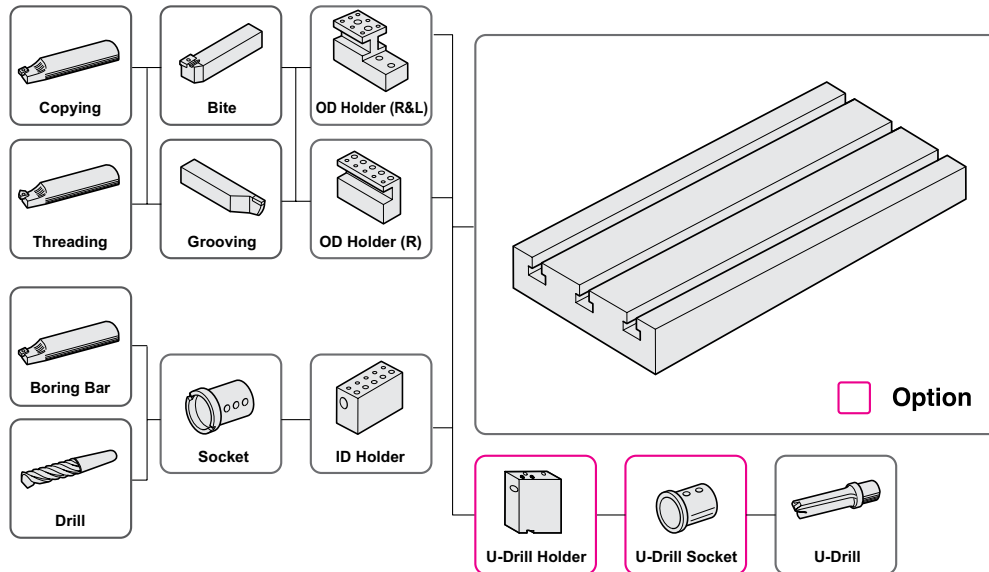

Tooling Parts Detail

ITEM			KIT60G	
			mm Unit	inch Unit
Turning Holder	O.D Holder	Right/Left : $\square 25$ ($\square 1"$)	2	2
		Double : $\square 25$ ($\square 1"$)	1	1
Boring Holder	I.D Holder	Single : $\varnothing 32$ ($\varnothing 1 \frac{1}{4}"$)	2	2
	U-Drill Holder	Tool Holder	Opt	-
		Cap	Opt	-
Socket	Boring	$\varnothing 8$ ($\varnothing 5/16"$)	Opt	-
		$\varnothing 10$ ($\varnothing 3/8"$)	1	1
		$\varnothing 12$ ($\varnothing 1/2"$)	1	1
		$\varnothing 16$ ($\varnothing 5/8"$)	1	1
		$\varnothing 20$ ($\varnothing 3/4"$)	Opt	Opt
		$\varnothing 25$ ($\varnothing 1"$)	Opt	Opt
	Drill	MT 1 \times MT 2	1	1
		MT 2	Opt	Opt
		$\varnothing 20$ ($3/4"$)	Opt	-
		$\varnothing 25$ ($1"$)	Opt	-

SPECIFICATIONS

Specifications

[] : Option

ITEM			KIT250	
CAPACITY	Swing Over the Bed	mm(in)	Ø320 (12.6")	
	Max. Turning Dia.	mm(in)	Ø135 (5.3")	
	Max. Turning Length	mm(in)	150 (5.9")	
	Bar Capacity	mm(in)	Ø32 (1.3")	
SPINDLE	Chuck Size	mm(in)	5"	
	Spindle Bore	mm(in)	Ø42 (1.7")	
	Spindle Speed (rpm)	r/min	7,000	
	Motor (Max/Cont.)	kW(HP)	5.5/3.7 (7.4/5)	
	Torque (Max/Cont.)	N·m(lbf·ft)	48/32.4 (35.4/23.9)	
	Spindle Type	-	BELT	
	Spindle Nose	-	FLAT Ø110 (4.3")	
FEED	Travel (X/Z)	mm(in)	250/200 (9.8"/7.9")	
	Rapid Traverse Rate (X/Z)	m/min(ipm)	24/30 (944.8/1,181)	
	Slide Type	-	LM GUIDE	
BLOCK TOOL	No. of Tools	EA	4	
	Tool Size	OD	mm(in)	□20 (□0.8")
		ID	mm(in)	Ø25 (1")
TANK CAPACITY	Coolant Tank	ℓ (gal)	115 (30.4)	
	Lubricating Tank	ℓ (gal)	1.8 (0.5)	
POWER SUPPLY	Electric Power Supply	kVA	8	
	Thickness of Power Cable	mm ²	OVER 16	
	Voltage	V/Hz	220/60 (200/50*)	
MACHINE	Floor Space (L×W)	mm(in)	1,690x1,640 (66.5"x64.6")	
	Height	mm(in)	1,670 (65.7")	
	Weight	kg(lb)	1,900 (4,189)	
PC	Controller	-	HYUNDAI WIA FANUC i Series - Smart plus	

*) Using 50Hz voltage instead of 60Hz may lower the output of motors. (excluding servo motors and inverter motors)
Specifications are subject to change without notice for improvement.

SPECIFICATIONS

Specifications

[] : Option

ITEM			KIT4500	
CAPACITY	Swing Over the Bed	mm(in)	Ø530 (Ø20.9")	
	Max. Turning Dia.	mm(in)	Ø165 (Ø6.5")	
	Max. Turning Length	mm(in)	300 (11.8") [Big Bore : 273 (10.7")]	
	Bar Capacity	mm(in)	Ø51 (Ø2") [Big Bore : Ø65 (Ø2.6")]	
SPINDLE	Chuck Size	mm(in)	6" [Big Bore : 8"]	
	Spindle Bore	mm(in)	Ø61 (Ø2.4") [Big Bore : Ø76 (Ø3")]	
	Spindle Speed (rpm)	r/min	6,000 [6,000] [Electric Chuck : 6,000] [Big Bore : 4,000 / 4,000]	
	Motor (Max/Cont.)	kW(HP)	15/11 (20/15) [25/10.5 (33.5/14.1)] [Electric Chuck : 20/10.5 (26.8/14.1)] [Big Bore : 15/11(20/15) / 25/10.5 (33.5/14.1)]	
	Torque (Max/Cont.)	N·m(lbf·ft)	95.5/70 (70.4/51.6) [120/50 (88.5/36.9)] [Electric Chuck : 143/75 (105.5/55.3)] [Big Bore : 191/140 (140.9/103.3) / 238/100 (175.5/73.8)]	
	Spindle Type	-	3V BELT	
	Spindle Nose	-	A2-5 [Big Bore : A2-6]	
FEED	Travel (X/Z)	mm(in)	450/300 (17.7"/11.8")	
	Rapid Traverse Rate (X/Z)	m/min(ipm)	30/36 (1,181/1,417)	
	Slide Type	-	LM GUIDE	
BLOCK TOOL	No. of Tools	EA	6	
	Tool Size	OD	mm(in)	□20 (□0.8")
		ID	mm(in)	Ø32 (1.2")
TANK CAPACITY	Coolant Tank	ℓ (gal)	120 (31.7)	
	Lubricating Tank	ℓ (gal)	1.8 (0.5)	
POWER SUPPLY	Electric Power Supply	kVA	17	
	Thickness of Power Cable	mm ²	OVER 16	
	Voltage	V/Hz	220/60 (200/50*)	
MACHINE	Floor Space (L×W)	mm(in)	2,170×1,470 (85.4" x 57.9")	
	Height	mm(in)	1,984 (78.1")	
	Weight	kg(lb)	2,800 (110.2)	
PC	Controller	-	HYUNDAI WIA FANUC i Series - Smart plus [SIEMENS 828D]	

*) Using 50Hz voltage instead of 60Hz may lower the output of motors. (excluding servo motors and inverter motors)
Specifications are subject to change without notice for improvement.

SPECIFICATIONS

Specifications

[] : Option

ITEM		KIT60G	
CAPACITY	Swing Over the Bed	mm(in)	Ø780 (Ø30.7")
	Max. Turning Dia.	mm(in)	Ø254 (Ø10")
	Max. Turning Length	mm(in)	530 (20.9")
	Bar Capacity	mm(in)	Ø65 (Ø2.6")
SPINDLE	Chuck Size	mm(in)	10"
	Spindle Bore	mm(in)	Ø66.2 (Ø2.6")
	Spindle Speed (rpm)	r/min	4,000
	Motor (Max/Cont.)	kW(HP)	15/11 (20/15)
	Torque (Max/Cont.)	N·m(lbf·ft)	191/140 (140.9/103.3)
	Spindle Type	-	BELT
	Spindle Nose	-	A2-10
FEED	Travel (X/Z)	mm(in)	450/550 (17.7"/21.7")
	Rapid Traverse Rate (X/Z)	m/min(ipm)	36/36 (1,417/1,417)
	Slide Type	-	LM GUIDE
BLOCK TOOL	No. of Tools	EA	6 [Grinding Spindle]
	Tool Size	OD	□ 25 (□ 1")
		ID	Ø32 (1.3")
TANK CAPACITY	Coolant Tank	ℓ (gal)	274 (72.4)
	Lubricating Tank	ℓ (gal)	1.8 (0.5)
POWER SUPPLY	Electric Power Supply	kVA	20
	Thickness of Power Cable	mm ²	OVER 16
	Voltage	V/Hz	220/60 (200/50*)
MACHINE	Floor Space (L×W)	mm(in)	2,900×1,650 (114.2" × 65")
	Height	mm(in)	1,870 (73.6")
	Weight	kg(lb)	4,300 (9,479.9)
NC	Controller	-	HYUNDAI WIA FANUC i Series - Smart plus [SIEMENS 828D]

*) Using 50Hz voltage instead of 60Hz may lower the output of motors. (excluding servo motors and inverter motors)
Specifications are subject to change without notice for improvement.

CONTROLLER

HYUNDAI WIA FANUC i Series – Smart plus

[] : Option

Controlled axis / Display / Accuracy Compensation	
Control axis	2 axis (X, Z) / 3 axis (X, Z, C) / 4 axis (X,Z,Y,C) 5 axis (X, Z, B, C, A) / 6 axis (X, Z, Y, B, C, A) 7 axis (X1/Z1, X2/Z2, B2, C1/C2)
Simultaneously controlled axis	2 axis [Max. 4 axis]
Designation of spindle axis	3 axis [Max. 4 axis]
Least setting Unit	X, Z, Y, B axis : 0.001 mm (0.0001 inch) C, A axis : 0.001 deg
Least input increment	X, Z, Y, B axis : 0.001 mm (0.0001 inch) C, A axis : 0.001 deg
Inch / Metric conversion	G20 / G21
High response vector control	
Interlock	All axis / Each axis
Machine lock	All axis
Backlash compensation	± 0~9999 pulses (exc. Rapid traverse / Cutting feed)
Position switch	
LCD / MDI	10.4 inch LCD unit
Feedback	Absolute motor feedback
Stored stroke check 1	Over travel
Stored stroke check 2, 3	
PMC axis control	
Operation	
Automatic operation (Memory)	
MDI operation	
DNC operation	Needed DNC software / CF card
Program restart	
Wrong operation prevention	
Program check function	Dry run
Single block	
Search function	Program Number / Sequence Number
Interpolation functions	
Pano interpolation	
Positioning	G00
Linear interpolation	G01
Circular interpolation	G02, G03
Exact stop mode	Single : G09, Continuous : G61
Dwell	G04, 0 ~ 9999.9999 sec
Skip	G31
Reference position return	1st reference : G28, 2nd reference : G30 Ref. position check : G27
Thread synchronous cutting	G33
Thread cutting retract	
Variable lead thread cutting	
Multi / Continuous threading	
Feed function / Acc. & Dec. control	
Manual feed	Rapid traverse Jog : 0~2,000 mm/min (79 ipm) Manual handle : x1, x10, x100 pulses Reference position return
Cutting Feed command	Direct input F code
Feedrate override	0 ~ 200% (10% Unit)
Rapid traverse override	1%, F25%, 50%, 100%
Override cancel	
Feed per minute	G98
Feed per revolution	G99
Look-ahead block	1 block
Program input	
Tape Code	EIA / ISO
Optional block skip	9 ea
Absolute / Incremental program	G90 / G91
Program stop / end	M00, M01 / M02, M30
Maximum command unit	± 999,999.999 mm (± 99,999.9999 inch)
Plane selection	X-Y : G17 / Z-X : G18 / Y-Z : G19
Workpiece coordinate system	G52, G53, 6 pairs (G54 ~ G59)
Manual absolute	Fixed ON
Programmable data input	G10
Sub program call	10 folds nested
Custom macro	#100 ~ #199, #500 ~ #999
G code system	A, B/C
Programmable mirror image	G51.1, G50.1
G code preventing buffering	G4.1
Direct drawing dimension program	Including Chamfering / Corner R

Program input	
Multiple repetitive cycles	1, 11
Canned cycle for turning	
Auxiliary function / Spindle speed function	
Auxiliary function	M & 4 digit
Level-up M Code	High speed / Multi / Bypass M code
Spindle speed function	S & 5 digit, Binary output
Spindle override	0% ~ 150% (10% Unit)
Multi position spindle orientation	M19 (S##)
FSSB Rigid tapping	
Constant surface speed control	G96, G97
Tool function / Tool compensation	
Tool function	T & 2 digit + Offset 2 digit
Tool life management	
Tool offset pairs	128 pairs
Tool nose radius compensation	G40, G41, G42
Geometry / Wear compensation	
Direct input of offset measured B	
Editing function	
Part program storage size	5,120m (2MB)
No. of registerable programs	1,000 ea
Program protect	
Background editing	
Extended part program editing	Copy, move and change of NC program
Memory card program edit	
Data input / output & Interface	
I/O interface	CF card, USB memory Embedded Ethernet interface
Screen hard copy	
External message	
External key input	
External workpiece number search	
Automatic data backup	
Setting, display and diagnosis	
Self-diagnosis function	
History display & Operation	Alarm & Operator message & Operation
Run hour / Parts count display	
Maintenance information	
Actual cutting feedrate display	
Display of spindle speed / T code	
Graphic display	
Operating monitor screen	Spindle / Servo load etc.
Power consumption monitoring	Spindle & Servo
Spindle / Servo setting screen	
Multi language display	Support 24 languages
Display language switching	Selection of 5 optional Languages
LCD Screen Saver	Screen saver
Unexpected disturbance torque	BST (Back spin torque limit)
Function for machine type	
Cs contour control (C & A axis)	Mill, MS, Y, SY, LF-Mill, TTMS, TTSY
Polar coordinate interpolation	Mill, MS, Y, SY, LF-Mill, TTMS, TTSY
Cylindrical interpolation	Mill, MS, Y, SY, LF-Mill, TTMS, TTSY
Polygon turning (2 Spindles)	Mill, MS, Y, SY, LF-Mill, TTMS, TTSY
Canned cycle for drilling	Mill, MS, Y, SY, LF-Mill, TTMS, TTSY
Spindle orientation expansion	MS, SY TTS, TTMS, TTSY
Spindle synchronous control	MS, SY TTS, TTMS, TTSY
Torque control	MS, SY TTS, TTMS, TTSY
Y axis offset	Y, SY, TTSY
Arbitrary angular control	Y, SY, TTSY
Composite / Superimposed control	MS, SY, TTS, TTMS, TTSY
Balance cutting	TTS, TTMS, TTSY
Option	
Fast ethernet	Needed option board
Data server	Needed option board
Protection of data at 8 levels	
Tool offset pairs	200 pairs
Helical interpolation	
Conversational Program	SmartGuide-i
Look-ahead Block	40 ea, 200 ea (AICC 11)

Figures in inch are converted from metric values.

The FANUC controller specifications are subject to change based on the policy of company CNC supplying.

CONTROLLER

SIEMENS 828D

[] : Option ☆ Needed technical consultation

Controlled axis / Display / Accuracy Compensation

Control axis	2 axis (X, Z) – Std.
	3 axis (X, Z, C) – Mill
	4 axis (X, Z, Y, C) – Y
	5 axis (X, Z, B, C, A) – MS
	6 axis (X, Z, Y, B, C, A) – SY
Simultaneously controlled axis	Max. 4 axis
Least setting Unit	X, Z, Y, B axis : 0.001 mm (0.0001 inch)
	C, A axis : 1 deg [0.001] deg
Least input increment	X, Z, Y, B axis : 0.001 mm (0.0001 inch)
	C, A axis : 1 deg [0.001] deg
Inch / Metric changeover	G70 (inch) / G71 (metric)
Interlock	All axis / Each axis
Backlash compensation	
Pitch error compensation	Leadscrew pitch error compensation
LCD / MDI	10.4 inch color LCD [15 inch color LCD (With Touch panel)]
Keyboard	QWERTY full keyboard
Stored stroke check	Over travel

Operation

Automatic operation	
MDI operation	
Program restart	
Program check function	Dry run / Program check / Machine lock
Single block	
Block search	Block search
Reposition	
Working area limit	Working area limitations

Interpolation functions

Positioning	G00
Linear interpolation	
Circular interpolation	Circular interpolation CW (G02)
	Circular interpolation CCW (G03)
Exact position stop	Single block exact stop (G09)
	Exact stop G60 (G601, G602, G603)
Dwell	Dwell (G04)
Reference position return	Return to reference point
	Return to 2nd reference point
Helical interpolation	
Thread synchronous cutting	
Thread cutting retract	
Spline interpolation	Non-uniform rational B splines

Feed function / Acc. & Dec. control

Manual feed	Rapid traverse
	Jog
	Manual handle
	Reference position return
Cutting Feed command	Direct input F code
Feedrate override	0 ~ 200% (10% Unit)
Rapid traverse override	1%, 25%, 50%, 100%
Feed per minute	G94
Feed per revolution	G95
Look-ahead block	1 block

Program input

ISO support	G291 (ISO) / G290 (SIEMENS)
	(ISO G Code system-A)
Optional block skip	2
Program stop / end	M00, M01 / M02, M30
Maximum command unit	± 999,999,999 mm, ± 99,999,9999 inch
Plane selection	X-Y : G17, X-Z : G18, Y-Z : G19 G54 ~ G57, G505~G549
Workpiece coordinate system	G500 (Basic frame – settable zero offset)
	G53 (Work offset non modal)
	G153 (basic frame non modal)
Sub program call	11 folds nested
G code preventing buffering	STOPRE
Turning Cycle	Turning programming (Cycle 93, 94, 95, 97)
User Cycle	

Auxiliary function / Spindle speed function

Auxiliary function	M Code 4 digit
Spindle speed function	S Code 5 digit
Spindle override	0% ~ 150% (10% Unit)
Spindle orientation	SPOS
Rigid tapping	
Automatic mode interchange	Spindle / Axis mode
Constant surface speed control	G96, G97
Spindle speed limitation	LIMS

Tool function / Tool compensation

Tool function	Tool number & Tool name Tool : T + Offset : D
Tool life management	128 ea : Std. 256 ea : Mill 768 ea : Y, MS, SY 256 ea : Std. 512 ea : Mill 1,536 ea : Y, MS, SY
Tools in tool list	
Cutting Edges in tool list	
Tool nose radius compensation	ISO (G40, G41, G42)
Geometry / Wear compensation	
Measurement of tool length	
Tool management function	

Editing function

Part program storage size	3MB – Std. 5MB – Mill 10MB – Y, MS, SY 750 ea
No. of registerable programs	750 ea
External Storage devices	Local network, Server, USB, Flash drive
Background editing	
Extended part program editing	Copy, move and change of NC program
Memory card program edit	

Data input / output & Interface

I/O interface	CF card interface (ONLY 10.4") USB memory interface Embedded Ethernet memory interface
Screenshot	

Setting, display and diagnosis

Self-diagnosis function	
History display & Operation	Alarm & Operator message & Operation
Run hour / Parts count display	
Maintenance information	
Actual cutting feedrate display	
Display of spindle speed / T code	
Graphic display	
Operating monitor screen	Spindle / Servo load etc. Support 9 languages Chinese (Simplified/Traditional), English, French, German, Italian, Korean, Portuguese, Spanish [☆ Support 22 languages : Inquiry need]
Multi language display	
LCD Screen Saver	Screen saver & Motion sensing

Function for machine type

Cs contour control (C & A axis)	Mill, MS, Y, SY model
Polar coordinate interpolation	Mill, MS, Y, SY model
Cylindrical interpolation	Mill, MS, Y, SY model
Canned cycle for drilling	Mill, MS, Y, SY model
[Polygon turning (CP-Basic)]	Mill, MS, Y, SY model
[Hobbing / Skybing (CP-Comfort)]	Mill, MS, Y, SY model
Spindle synchronous control	MS, SY model
Servo tailstock function	MS, SY model

Option

Additional optional block skip	10
Contour handwheel	
3D simulation	
Real time simulation	
Shop Turn	Machining step programming for turning



You Tube HYUNDAI WIA MT
www.youtube.com/HYUNDAIWIAMT

CREATING VALUE IN SEAMLESS MOBILITY

With its top-quality HYUNDAI WIA machine tool creates a new and better world.



<http://machine.hyundai-wia.com>
HYUNDAI WIA Machine Tools
Global Links

HEADQUARTER

R&D Center/Factory 153, Jeongdong-ro, Seongsan-gu, Changwon-si, Gyeongsangnam-do, Korea TEL : +82 55 280 9114 FAX : +82 55 282 9114

Overseas Sales Team /R&D Center 37, Cheoldobangmulgwan-ro, Uiwang-si, Gyeonggi-do, Korea TEL : +82 31 8090 2539

OVERSEAS OFFICES

HYUNDAI WIA Machine America corp. 450 Commerce Blvd, Carlstadt, NJ 07072, USA TEL : +1-201-987-7298

HYUNDAI WIA Europe GmbH Alexander-Fleming-Ring 57, 65428 Rüsselsheim Germany TEL : +49-0-6142-9256-0

HYUNDAI WIA Machine Tools China Company No.16 Fenghuang Road, Fenghuang Town, Zhangjiagang City, Jiangsu Province, China TEL : +86-21-6427-9885

India Branch Office #4/169, 1st Floor, LOTTE BLDG, Rajiv Gandhi Salai, (OMR), Kandanchavadi, Chennai - 600096, Tamilnadu, India TEL : +91-76-0490-3348